

**VB**  
**VBN**  
**VBT**

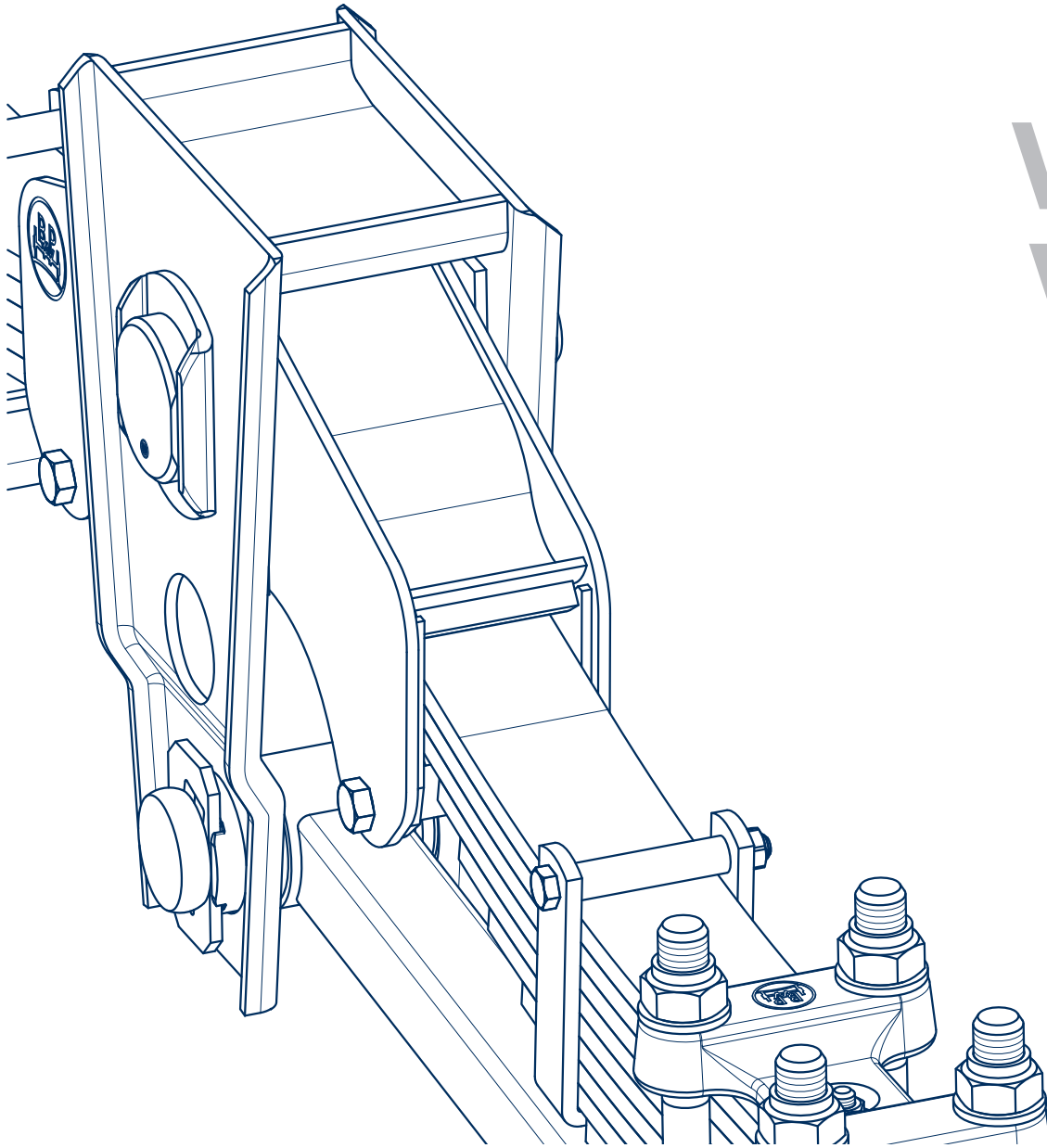

# BPW Original-Spare parts

Mechanical suspensions (from 9 t)

series VB / VBN / VBT

ECO Cargo VB / ECO Cargo VBN



# Contents

		Page
	<b>Explanation of BPW suspension type codes</b>	4 / 5
	<b>Explanation of BPW code numbers</b>	6
	<b>BPW Type plate</b>	7
	<b>General explanation of BPW VB suspensions</b>	8 / 9
◎ 1	<b>Axle alignment</b>	10 - 13
1.1	Axle alignment conventional	10 / 11
1.2	Axle alignment with laser measuring system	12
1.3	Axle alignment correction	13
◎ 2	<b>Leaf springs</b>	14 - 18
2.1	General	14 / 15
2.2	Leaf springs, anti-vibration leaves	16 / 17
2.3	Spare parts for leaf springs	18
◎ 3	<b>Axle beams</b>	20
◎ 4	<b>Axle clampings</b>	21 - 31
4.1	General	21
4.2	Spring seats, supports	22 - 25
4.3	Spring plates, segments	26 - 29
4.4	Spring U-bolts	30 / 31
◎ 5	<b>Connecting rods</b>	32 - 38
5.1	General	32 / 33
5.2	Connecting rods, spare parts	34 / 35
5.3	Connecting rod attachments	36 - 38
◎ 6	<b>Front hanger brackets</b>	40 - 45
6.1	General	40 / 41
6.2	Spare parts for front hanger brackets	42 - 45
6.2.1	Weld-in bushes	42 / 43
6.2.2	Supports, sliders and attachment parts	44 / 45
◎ 7	<b>Equalizing beams</b>	46 - 61
7.1	General	46 / 47
7.2	Spare parts for equalizing beams	48 - 61
7.2.1	Equalizing beams	48 / 49
7.2.2	Weld-in bushes	50 - 43
7.2.3	Equalizing beam bearing - Bushes, wear plates	54 / 55
7.2.4	Equalizing beam bearing - Threaded bolts	56 / 57
7.2.5	Supports, sliders and attachment parts	58 - 61
◎ 8	<b>Rear hanger brackets</b>	62 - 67
8.1	General	62 - 63
8.2	Spare parts for rear hanger brackets	64 - 67
8.2.1	Weld-in bushes	64 / 65
8.2.2	Supports, sliders and attachment parts	66 / 67
◎ 9	<b>Supports for VBT</b>	68 / 69
◎ 10	<b>Stabilizer</b>	70
◎ 11	<b>Lubrication and maintenance work</b>	71

Vaild: 01.06.2021

This spare parts list shows fast moving parts for BPW suspensions **series VB / VBN / VBT**.

For further spare parts see BPW spare parts catalogue and / or spare parts lists of the corresponding single axles without bogie parts.

Current versions and additional information can be found online at [www.bpw.de](http://www.bpw.de).

Subject to change (without notice).

Ⓜ -parts are embossed with BPW Code no.

# Contents (Exploded View)

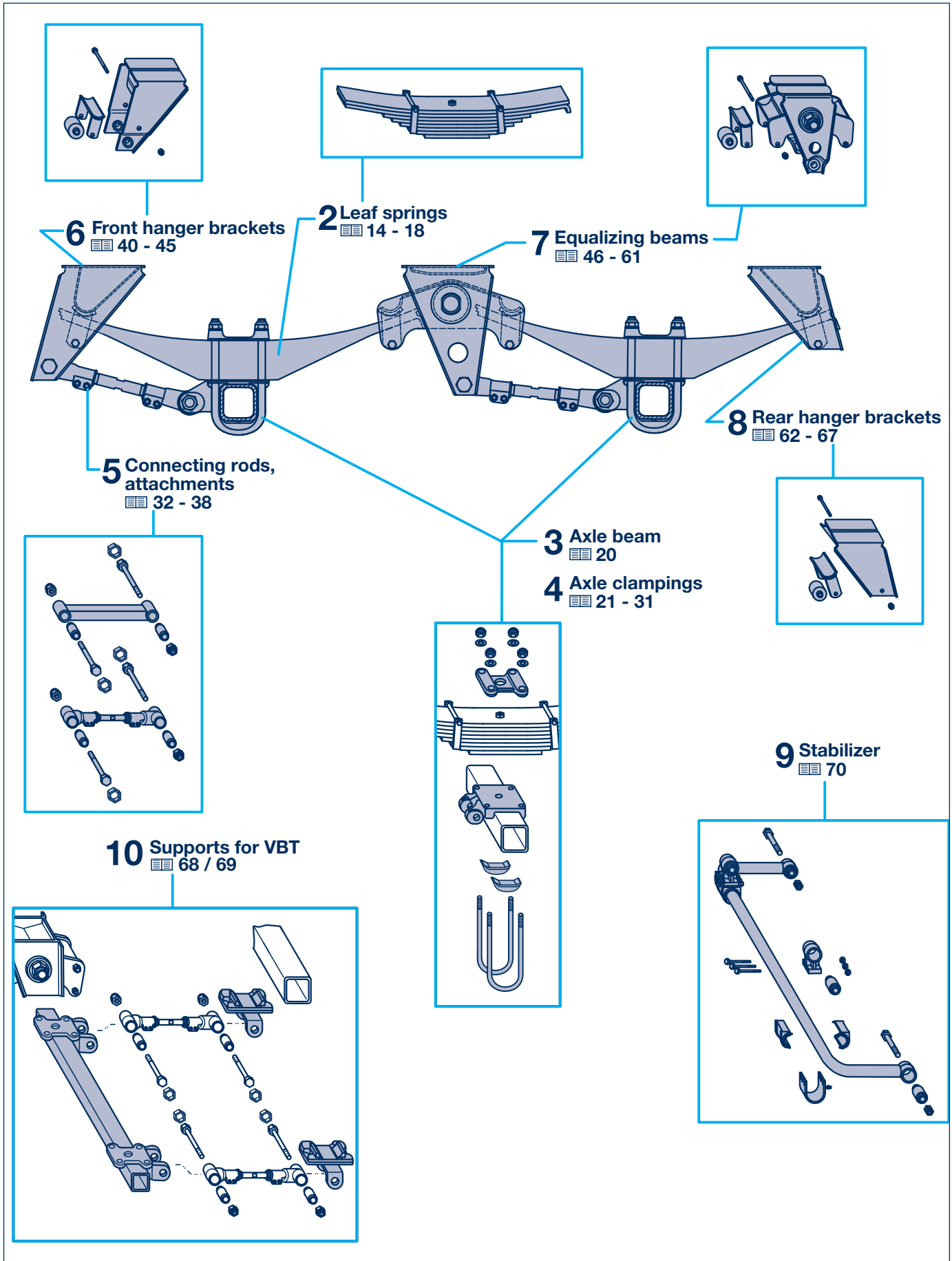

# Explanation of BPW suspension type codes

## Mechanical suspensions series VB (extract)

Example:												
H	S	F	H	VB	U	LL	3/	9010	/12°	M	ECO Plus 3	ECO Cargo
										<b>Trailer axle</b>	<b>Brake</b>	<b>Tyre size</b>
<b>H</b>										<b>H..</b>	SN 420	20" - 24"
<b>K</b>										<b>K..</b>	SN 360	19.5"
<b>N</b>										<b>N..</b>	SN 300	15" (12"-17.5")
<b>a.o.</b>	Further axle types see BPW type designations											
<b>B</b>	For single wheels, wheels with offset											
<b>S</b>	For single wheels, wheels without offset											
<b>Z</b>	For twin wheels											
<b>I</b>	Wheel spiders for TRILEX wheel rims, single wheels											
<b>IZ</b>	Wheel spiders for TRILEX wheel rims, twin wheels											
<b>F</b>	Wheel studs M 22 x 1.5 without wheel nuts, order wheel nuts for stud or spigot alignment separately											
<b>M</b>	For spigot alignment, alloy wheels											
<b>H</b>	For hanging boosters											
<b>Suspension series</b>												
<b>VB</b>	<b>VB</b> Mechanical suspension without braking load compensation, leaf springs above the axle											
<b>VBN</b>	<b>VBN</b> Mechanical suspension without braking load compensation, leaf springs above the axle, low design, only with <b>VB ECO Cargo</b>											
<b>VBT</b>	<b>VBT</b> As <b>VB</b> , but leaf springs below the axle											
<b>U</b>	With U-stabilizer											
<b>L</b>	With steering axle, series <b>L</b>										Steering angle max. 40°	
<b>LL</b>	With self-steering axle, series <b>LL</b>										Steering angle max. 27°	
<b>LS</b>	With self-steering axle, series <b>LS</b>										Steering angle max. 20°	
-	Single axle											
2/	Tandem axle suspension											
3/	Tri-axle suspension											
6006 to 20010	Axle load (kg) + quantity of wheel studs per hub											
/12° to /40°	Steering angle of steering axle											

# Explanation of BPW suspension type codes

## Mechanical suspensions series VB (extract)

Example:										
HSFH	VB	U	LL	3/	9010	/12°	M	ECO Plus 3	ECO Cargo	
										<b>Exec. index</b>
							<b>B</b>			<b>B</b> Reinforced
							<b>BE</b>			<b>BE</b> Reinforced, equalizer bearing with bronze bushes
							<b>C</b>			<b>C</b> Open hanger bracket with screwed on sliders
							<b>HD</b>			<b>HD</b> Heavy duty execution
							<b>HDE</b>			<b>HDE</b> Heavy duty execution, equalizer bearing with bronze bushes
							<b>E</b>			<b>E</b> Equalizer bearing with bronze bushes
							<b>K</b>			<b>K</b> Weight-optimised version 9 to 10 t
							<b>KE</b>			<b>KE</b> Equalizer bearing with bronze bushes
							<b>KN</b>			<b>KN</b> Low construction height
							<b>L</b>			<b>L</b> Reinforced
							<b>LE</b>			<b>LE</b> Reinforced, equalizer bearing with bronze bushes
							<b>M</b>			<b>M</b> Reinforced
							<b>ME</b>			<b>ME</b> Reinforced, equalizer bearing with bronze bushes
							<b>MN</b>			<b>MN</b> Reinforced, low construction height
							<b>MNE</b>			<b>MNE</b> Reinforced, low construction height, equalizer bearing with bronze bushes
										<b>Hub bearing execution</b>
							<b>ECO</b>			BPW trailer axle with ECO Unit, 1996 (1998) -
							<b>ECO-MAXX</b>			Weight-optimised BPW trailer axle with ECO Unit, - 2003
							<b>ECO<sup>Plus</sup></b>			Weight-optimised BPW trailer axle with ECO <sup>Plus</sup> Unit, 2003 -
							<b>ECO Plus 2</b>			Weight-optimised BPW trailer axle with ECO Plus 2 Unit, 2007 -
							<b>ECO Plus 3</b>			Weight-optimised BPW trailer axle with ECO Plus 3 Unit, 2015 -
							<b>MAXX</b>			Weight-optimised BPW trailer axle with konv. hub bearing system
							<b>ECO Cargo</b>			Running gear system as from 2013

# Explanation of BPW code numbers

## Mechanical suspensions series VB (extract)

Example:								
39.	68.	743.	007					
				<b>1. + 2. digit</b>				
21.		Single axle with suspension parts						
28.								
30.								
38.								
22.		Tandem axle suspension / Tri-axle suspension						
32.								
23.		Tandem axle suspension / Tri-axle suspension						
32.								
39.								
				<b>3. + 4. digit</b>				
				<b>Axle load</b>	<b>Roller bearings</b>	<b>Trailer axle</b>	<b>Year of manuf.</b>	<b>Remark</b>
06.		6500 kg	33116 / 32310	H.. / K.. / N..	1982 -	Conventional hub bearing system		
08.		8000 - 9000 kg	33116 / 32310	H.. / K.. / N..	1982 -			
09.								
10.		10000 - 12000 kg	33118 / 33213	H.. / K.. / N..	1982 -			
14.		13000 - 14000 kg	32219 / 33215	H.. / K.. / N..	1983 -			
16.		16000 - 18000 kg	32222 / 32314	H..	1983 -			
20.		20000 kg	32224 / 32316	H..	1983 -			
36.		6500 kg	33116 / 32310	H.. / K.. / N..	1991 (1992) -	ECO / ECO-MAXX Unit		
37.		8000 - 9000 kg	33116 / 32310	H.. / K.. / N..	1991 (1992) -			
38.								
39.								
40.		10000 - 12000 kg	33118 / 33213	H.. / K.. / N..	1991 (1992) -			
41.								
44.		13000 - 14000 kg	32219 / 33215	H..	1994 -			
48.		8000 - 9000 kg	33118 / 33213	H.. / SH..; KH.. / SKH..; NH..	2000 -	ECO <sup>Plus</sup> Unit		
49.								
50.		10000 - 12000 kg	33118 / 33213	H.. / SH..; KH.. / SKH..; NH..	2000 -			
51.								
56.		6500/7000 kg	33118 / 33213	H.. / NH..	2007 -	ECO Plus 2 Unit		
58.								
59.		8000 - 9000 kg	33118 / 33213	H.. / SH..; KH.. / SKH..; NH..	2007 -			
64.		6000 kg	30313 / 32309	EH..	- 1980	Conventional hub bearing system		
65.		6400 kg	33215 / 32310	KR..	1985 -			
66.		6500 kg	33118 / 33213	H.. / SH..; KH.. / SKH..;	2015 -	ECO Plus 3 Unit		
68.		8000 - 9000 kg	33118 / 33213	NH..				
85.		8000 kg	33215 / 32310	EH.. / ZR..	1967 - 1982	Conventional hub bearing system		
86.		10000 kg	33217 / 33213	EH.. / ZR..	1966 - 1982			
87.		20000 kg	32224 / 32316	EH..	- 1983			
89.		16000 kg	32222 / 32314	EH..	- 1983			
				<b>5. - 6. digit (ECO Plus 3)</b>				
10.		<b>Designation of wheel brake in the case of ref. number 20... - 39...</b> For explanation of code number, see EL-HKN / EL-TS2/TSB / BPW code number designation						
-								
43.								
				<b>5. - 7. digit</b>				
501.		<b>Designation of wheel brake in the case of ref. number 20... - 39...</b> For explanation of code number, see EL-HKN / EL-TS2/TSB / BPW code number designation						
-								
839.								
				<b>8. - 10. digit</b>				
000 /		Consecutive number 000 - 999						
0000		Consecutive number 0000 - 9999 (ECO Plus 3)						

# Explanation of BPW code numbers and suspension types

## BPW Type plate

### Type plate at axle beam (Axle type plate)

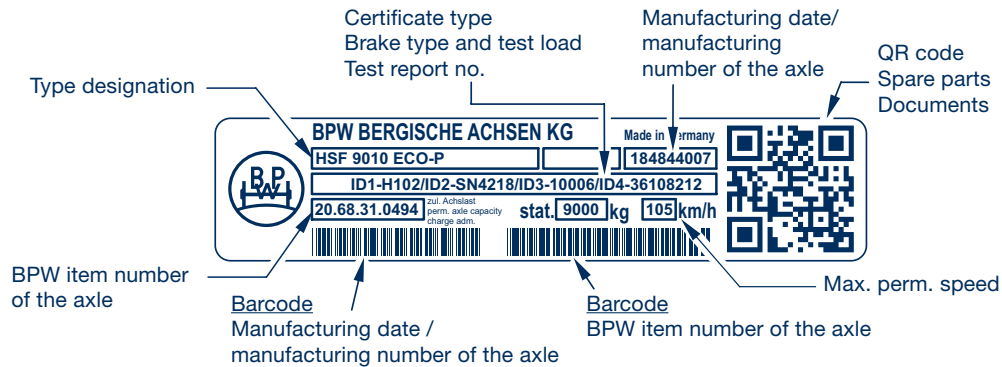

	Example:
The BPW type name is composed of a letter group and a number group.	<b>HSF 9010-15 ECO-P</b>
The letter group identifies the type of axle and suspension version as well as defining the hub version.	<b>HSF</b> - BPW axle series <b>H</b> for single wheels (without offset), wheel studs M 22 x 1.5, <b>without</b> wheel nuts
The number group specifies the axle load on the ground in kilogrammes and the number of wheel studs per wheel hub (for disc wheel connection).	<b>9010</b> - <b>9000</b> kg axle load - <b>10</b> wheel studs per wheel
The group of letters at the end of the model name defines the type of hub bearing.	<b>ECO-P</b> - <b>ECO Plus</b> bearing generation
You can view the brake certificate referenced by certificate type/test report number on the type plate by logging onto the BPW website at <a href="http://www.bpw.de">www.bpw.de</a> (Download Centre in the German version of the website - „Bremsgutachten“).	e.g.: ID1-H102/ID2-SN4218/ID3-10006/ID4-36108212 <b>ID1-H102</b> Certificate type <b>ID2-SN4218</b> Brake <b>ID3-10006</b> Tested axle load <b>ID4-36108212</b> Test report no.

### Type plate on hanger brackets and equalizing beams in the case of VB ECO Cargo

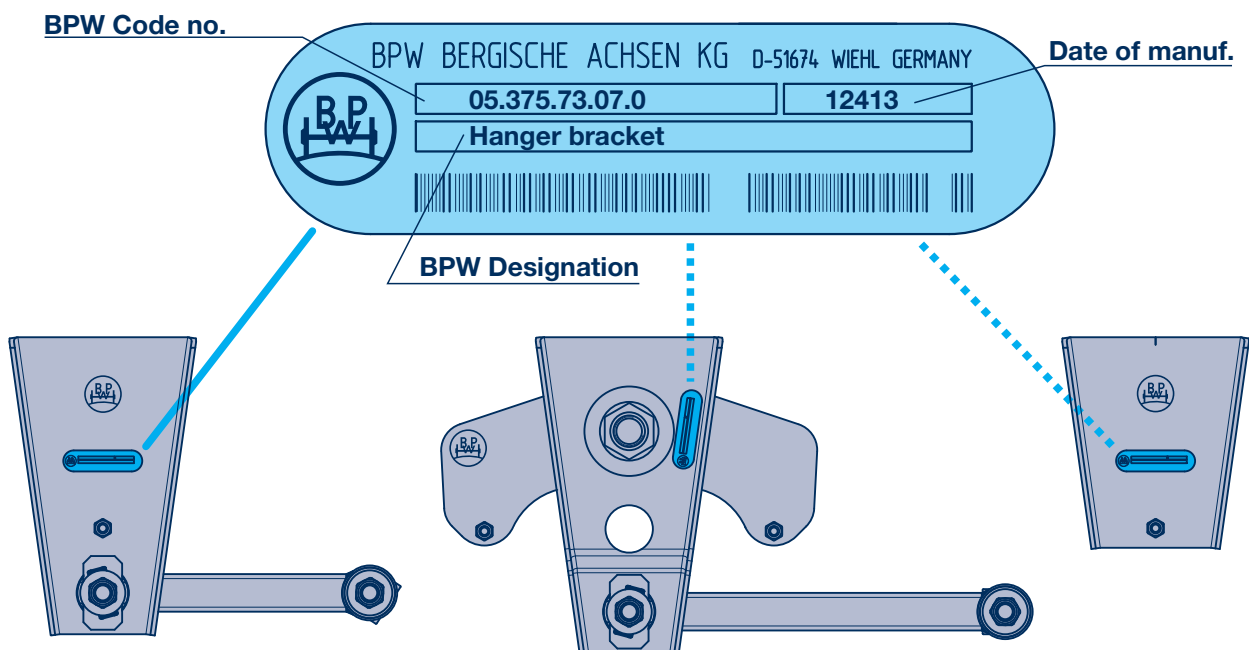

All BPW parts and components are provided with a 10 digit „speaking“ code number.

# Mechanical suspensions series VB

## General

### BPW VB suspension units for trailers and semi-trailers. Sturdy leaf springs for the most demanding applications.

Whether on roads or tracks, local or long-distance - BPW VB leaf-spring suspension systems can be relied upon one hundred percent.

They are extremely sturdy, and their tried and tested design stands up to the harshest challenges.

They are purely mechanical in operation. As a result they are easy to repair, even in circumstances where the infrastructure is poor.

With our VB suspension units for trailers and semitrailers, axle loads of 9 tonnes and more are no problem.

### Leaf spring installation

Series <b>VB</b>	Leaf spring above the axle beam
Series <b>VBN</b>	Leaf spring above the axle beam
Series <b>VBT</b>	Leaf spring below the axle beam

Axle location is undertaken by separate connecting rods, which are adjustable on one side (or both) to enable the tracking to be set with ease (see also page 16).

Suspension axles can be quickly aligned through **VB ECO Cargo** hanger brackets and equalizing beams with integrated wheel alignment:

Production tolerances on the vehicle can be equalised or wheelbases corrected (axle tracking).

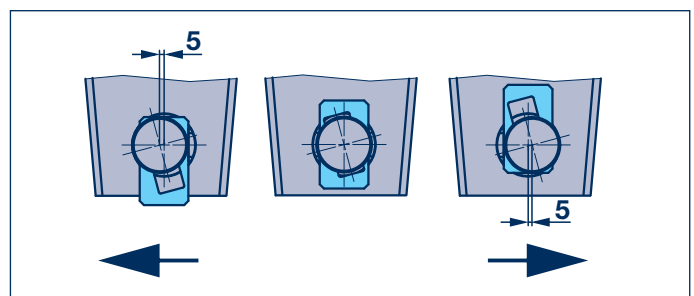
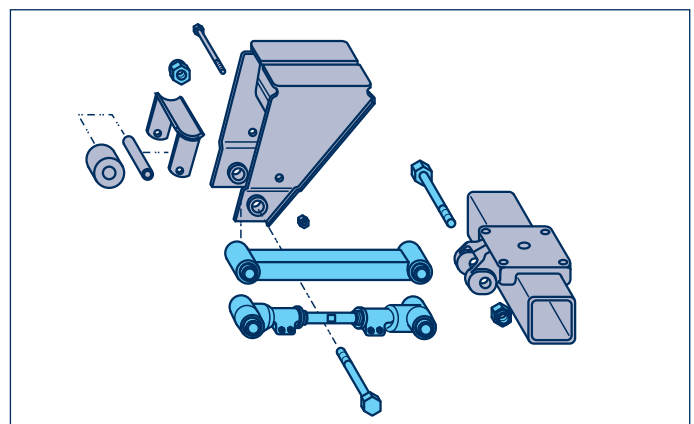
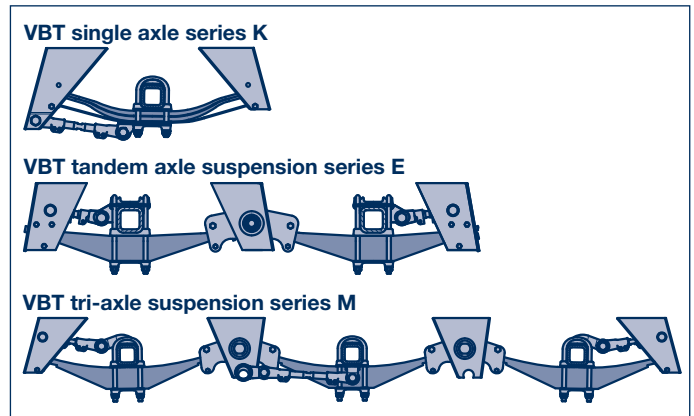
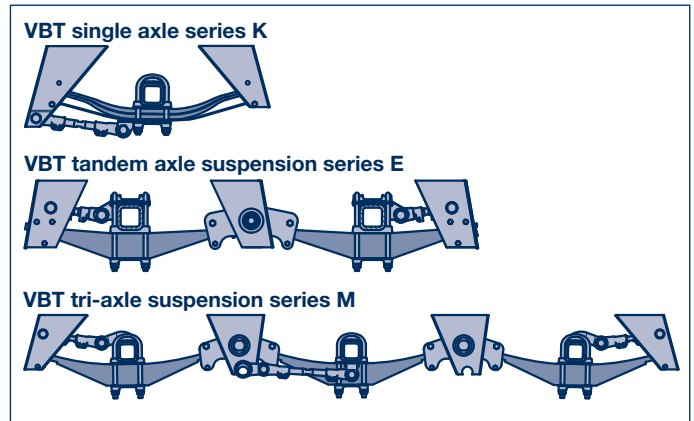



# Mechanical suspensions series VB

## General

### Mode of operation

In multi-axle suspension systems, the middle connecting pieces have equalising beams which can rotate. The spring ends which slide in the equalising beam mountings combine to produce static axle load equalisation (even distribution of axle load when stationary and moving). The design means that no dynamic axle load equalisation is provided (uneven axle load distribution when braking). BPW leaf suspension systems are designed to offer self-damping and do not need any additional shock absorbers.

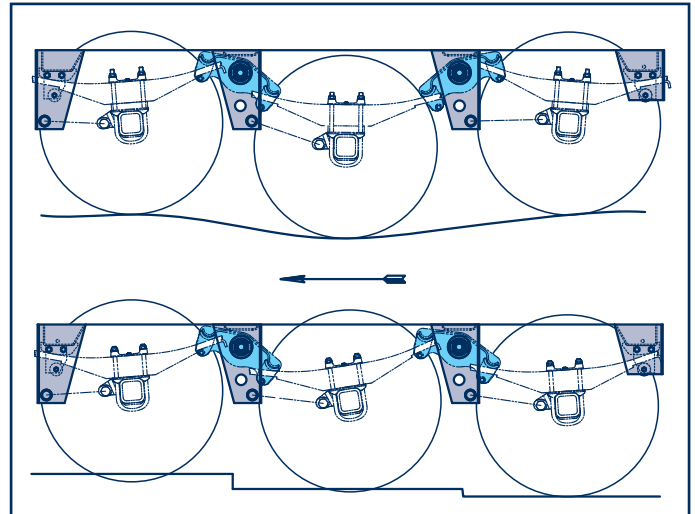

### BPW VB suspension units with anti-roll bar

**BPW VB** suspension units can also be equipped with one or more U-stabilisers when particularly high levels of roll stability are called for, e.g. in vehicles with a high centre of gravity.

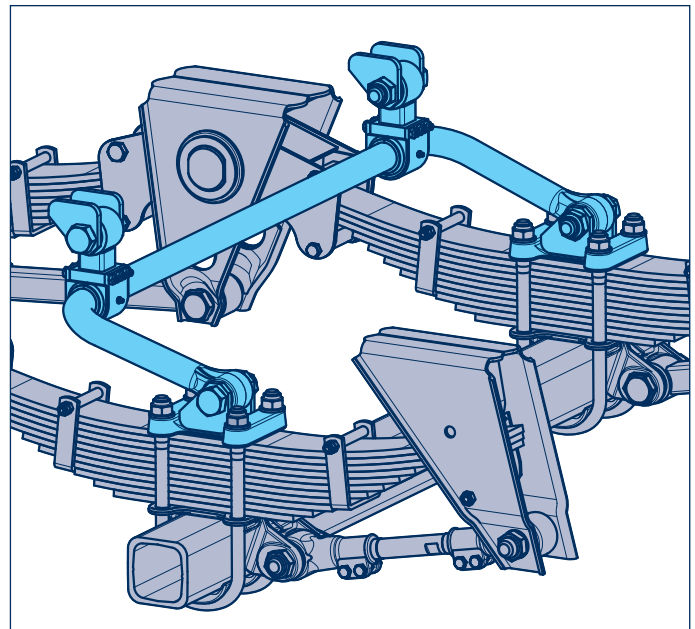

# 1 Axle alignment

## 1.1 Axle alignment conventionel

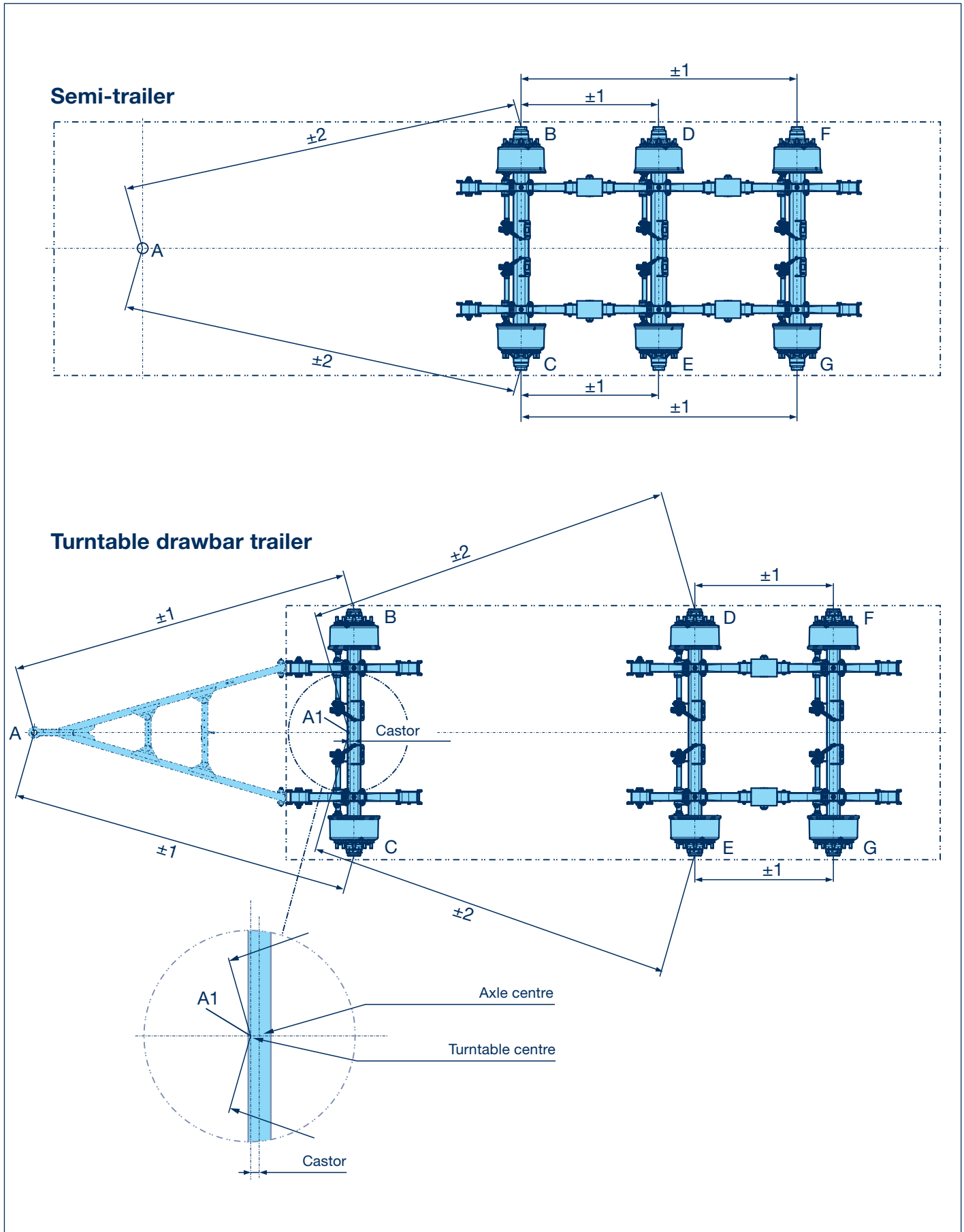

# Axle alignment 1

## Axle alignment conventional 1.1

After repairs have been carried out on the axle beam, connecting piece, connecting rods etc., the axle alignment must be checked and if necessary corrected.

### Semi-trailers:

Determine diagonal dimensions **A - B** and **A - C** for the front axle (reference axle) using comparative measurements and correct if necessary.

Check wheel base measurements **B - D** and **C - E** for the centre axle and **B - F** and **C - G** for the rear axle and correct if necessary.

### Turntable drawbar trailers:

Determine diagonal dimensions **A - B** and **A - C** for the front axle (reference axle) using comparative measurements and correct if necessary.

Determine diagonal dimensions **A1 - D** and **A1 - E** for the centre axle using comparative measurements and correct if necessary.

Check wheel base measurements **D - F** and **E - G** for the rear axle and correct if necessary.

Measurements are generally taken from the centre of the hub cap (Fig.).

It can also be carried out using suitable distancing devices or screwed-on calibration tubes.

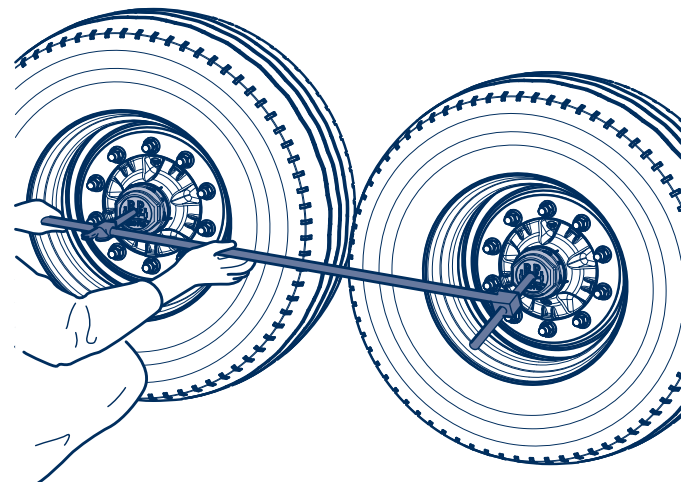

The triangle in the BPW logo is in the centre and can be used for holding a measuring tool.

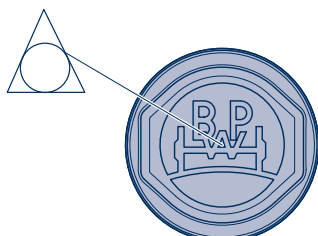

### IMPORTANT:

This method only takes into consideration the distances of the axles, but not the individual tracking values on the axle sides. This is sufficient for axles with optimal tracking values. This conventional method has a higher probability of incorrect measurements than the laser method (Chapter 11.2).

The measurement of smaller differences across greater lengths can be impacted by factors such as the elasticity in the measuring tool (manual force).

The tracking tolerances defined by BPW must be maintained. Only by maintaining these tolerances can low-wear operation of the vehicle be assured.

The tracking values are set for steered axles at the factory and the steering rod must not be adjusted.

# 1 Axle alignment

## 1.2 Axle alignment with laser measuring system

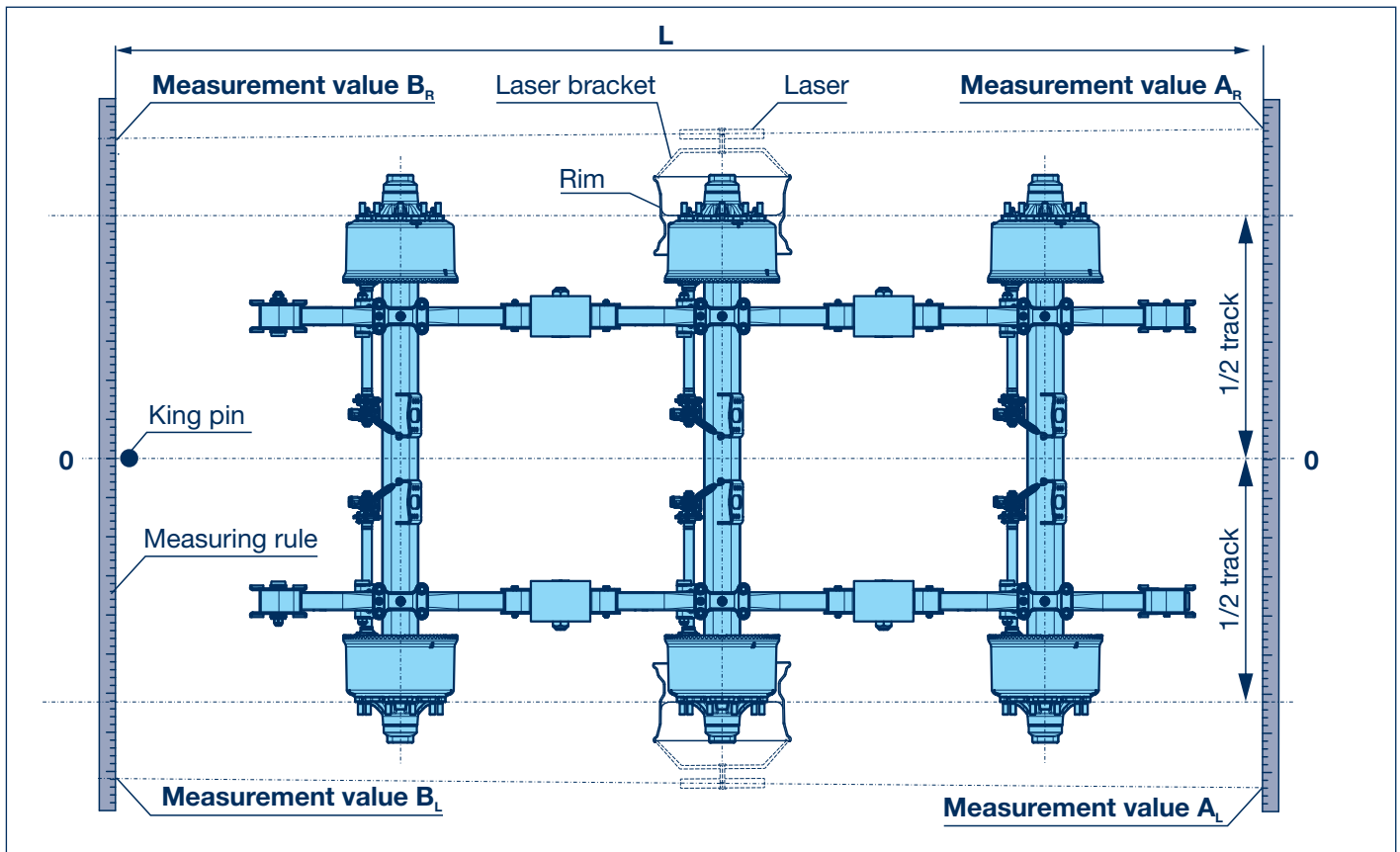

If laser measuring systems are used, care must be taken to ensure that the axle is aligned **horizontally** with the base in order to obtain a correct measurement as otherwise the camber values will affect the result. It is assumed that the vehicle does not carry any loads.

The operating and setting instructions of the system manufacturer must be adhered to!

The maximum possible wheelbase correction per axle is  $\pm 5$  mm for adjustable hanger brackets (see track settings with adjustable hanger brackets).

During the tracking process, the tracking values of the right and left wheel side must be averaged for each axle. Instead of measuring all three axles using the laser method, it is also possible to only track the mid-axle using the laser method.

The front and rear axle are positioned relatively to the mid-axle using suitable axle centre distance devices (like during conventional tracking).

### Calculation of the toe-in and toe-out settings:

$$\frac{(AR - BR) + (AL - BL)}{L} = \text{Axle track (mm/m)}$$

Positive value = toe-in

Negative value = toe-out

**The total of the values is the toe-in/toe-out value of the axle and must be within the permitted tolerance range.**

### Target values (total axle track):

- ⊙ Rigid axle  
=> -1 ... + 5 mm/m
- ⊙ Self-steering axle  
=> 0 ... + 4 mm/m (drum brake)

### IMPORTANT:

The tracking tolerances defined by BPW must be maintained. Only by maintaining these tolerances can low-wear operation of the vehicle be assured.

The tracking values are set for steered axles at the factory and the steering rod must not be adjusted.

# Axle alignment 1

## Axle alignment correction 1.3

### ECO Cargo VB

The maximum possible wheel base correction per axle for adjustable hanger brackets (ECO Cargo VB) is  $\pm 5$  mm.

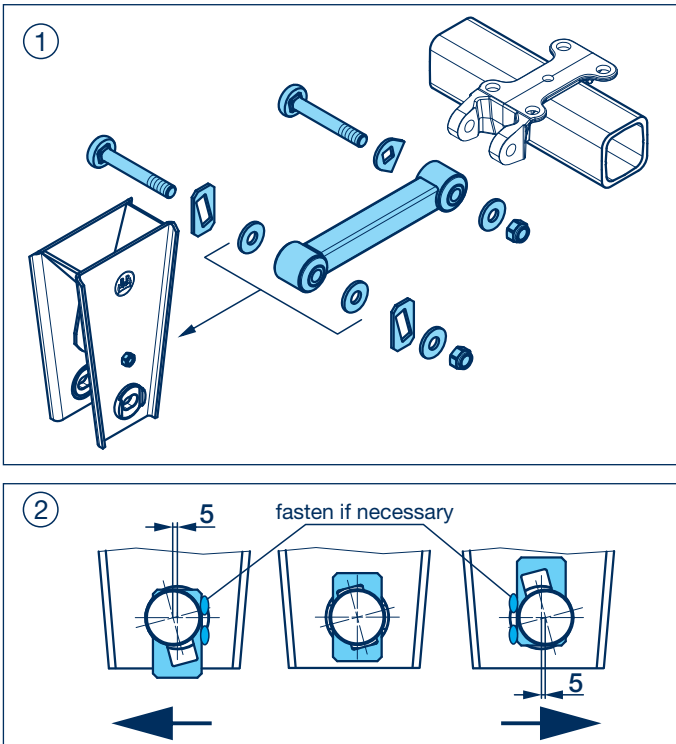

### ECO Cargo VB HD / VBT

Each rigid and adjustable connecting rod enables easy tracking of the suspension axles.

For some suspension unit versions, two adjustable connecting rods are also fitted for each axle.

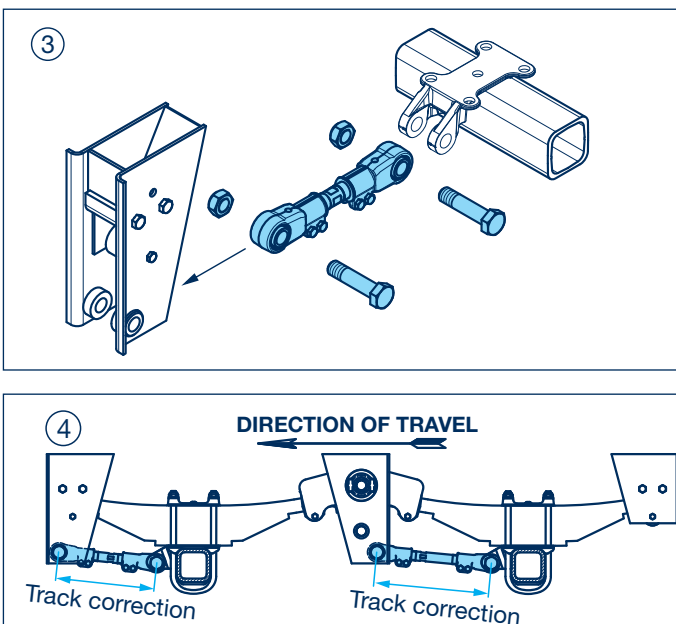

### Axle alignment correction

1. Raise and support the vehicle frame.
2. Loosen locking nut M 24 (SW 36) on the connecting rod mounting (Fig. ①).
3. For tandem and tridem: firstly align the front axle, then the other axles.
4. Slide the connecting linkage on both sides, as required, upwards or downwards with light hammer blows (Fig. ②).
5. **Make sure the inner and outer connecting linkages on each hanger bracket are adjusted symmetrically!**
6. Tighten locking nut M 24 (SW 36) with the prescribed tightening torque.  
M = 650 Nm (605 - 715 Nm)
7. For difficult road conditions, the connecting linkages can be affixed following alignment (Fig. ②).
8. Remove supports under the vehicle frame.

### Axle alignment correction

1. Raise and support the vehicle frame.
2. Loosen locking nuts M 12 / M 14 from the connecting rod clamp connections (Fig. ③).
3. For tandem and tridem: firstly align the front axle, then the other axles.
4. Align the axle by turning the adjusting spindle (left-right thread) (Fig. ④).
5. Tighten locking nuts M 12 / M 14 with the prescribed tightening torque.  
M 12            M = 66 Nm  
M 14            M = 140 Nm
6. Remove supports under the vehicle frame.

## 2 Leaf springs

### 2.1 General

BPW VB suspension units are equipped with parabolic or multi-leaf springs.

Depending on the version, parabolic springs have two or three parabolic rolled spring layers. The efficient use of material enables them to combine low weight with a low height.

Multi-leaf springs (trapezoidal springs) contain a stack of spring layers with a constant cross-section and graded lengths to give a trapezoidal shape.

They are characterised by their robustness and good default driving properties as well as the ease of replacing individual spring layers.

The ends of the leaf springs are mounted on sliding bearings using spring slides both in the connecting pieces and in the equalising beams.

This allows the spring pack to increase in length without obstruction when the suspension deflects.

As a load-bearing component of the suspension unit, the leaf spring requires particular attention.

The following instructions should be carefully adhered to during repair and maintenance work:

- ⦿ Do not work on leaf springs with a hammer or any sharp objects.
- ⦿ Do not work on leaf springs with cutters or grinders. In the event that replacement springs or leaves do not fit exactly into the seat of the spring pads, the mounting seat must always be widened.
- ⦿ Double or triple parabolic springs can only be completely replaced. Individual leaves can be replaced in multi-leaf springs.

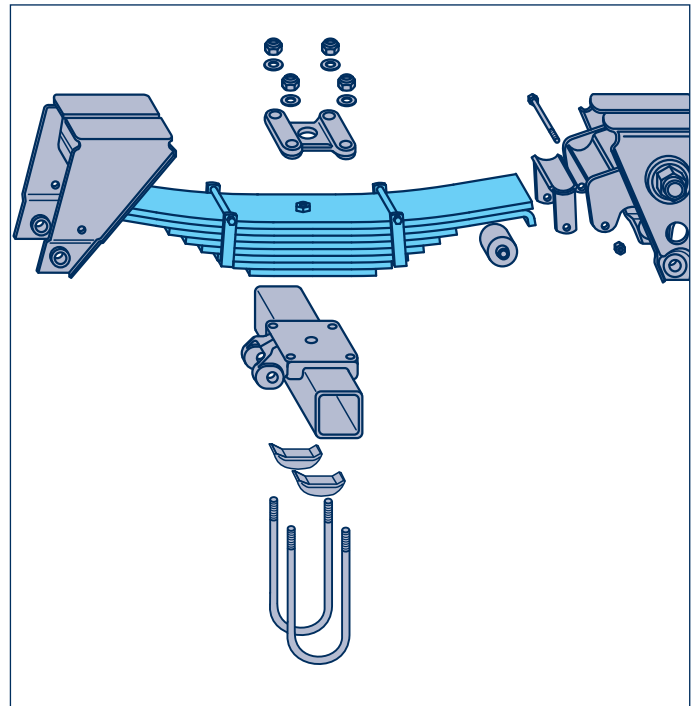
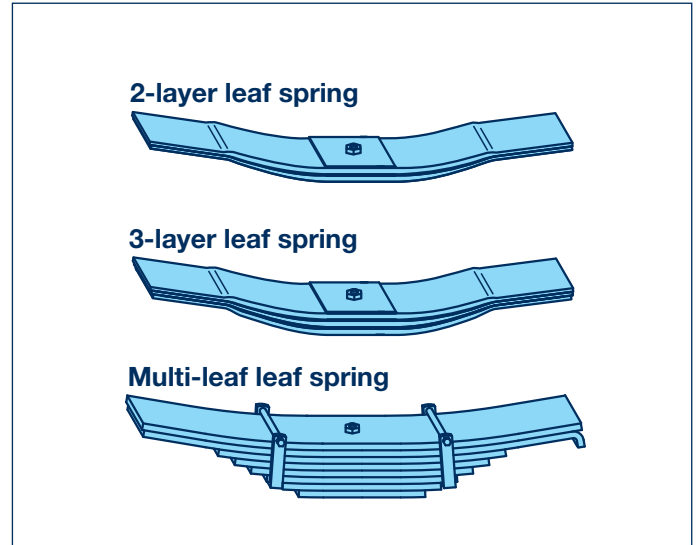

#### Important for all welding work !

The leaf springs, plastic pipings and other sensitive parts should be protected against sparks and weld splashes during all welding work.

The earth terminal must under no circumstances be attached to the leaf spring or hub.

# Leaf springs 2

## General 2.1

### BPW Code number

The BPW code number of the leaf spring is stamped into one of the spring layers or into the spring shackle.

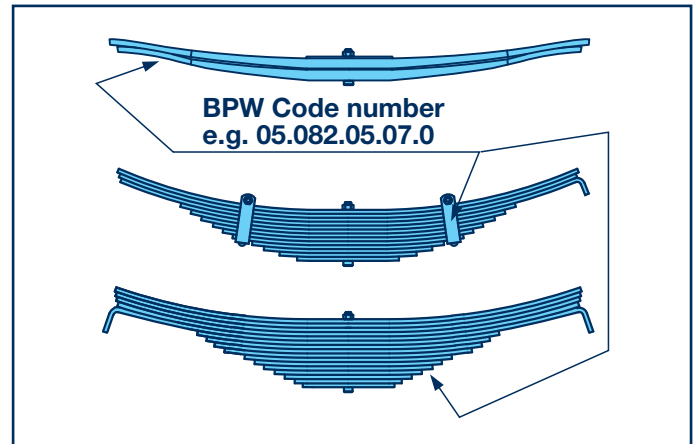

Up to 1996, BPW leaf springs for VB suspension units were supplied with two hooked ends.

After that the leaf springs were only manufactured with one hooked end.

When replacements are needed, we now only supply leaf springs or spring layers with one hooked end.

When installed, the hooked end must be fitted towards the rear (see arrow).

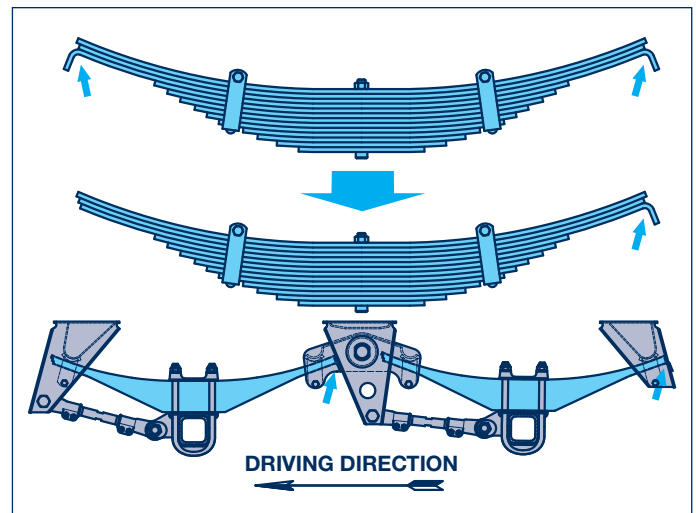

The contact points between the leaf springs and the retainers or sliders must be well greased in order to prevent unnecessary wear and rattling.

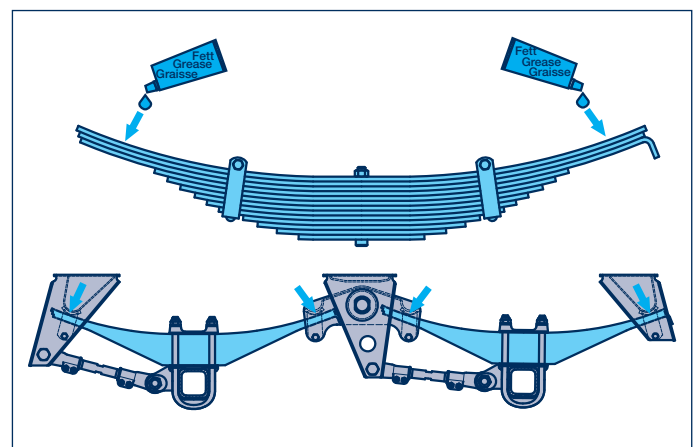



# 2 Leaf springs

## 2.2 Leaf springs, anti-vibration leaves

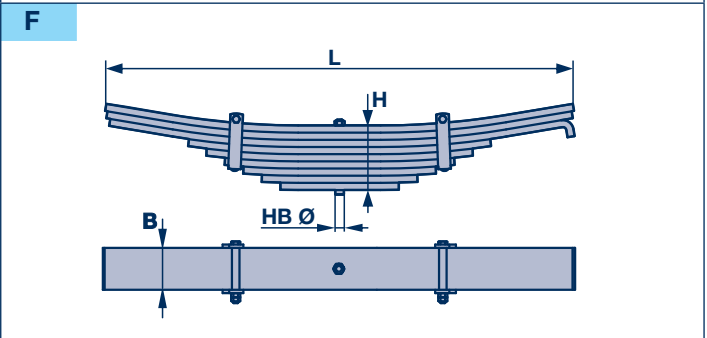
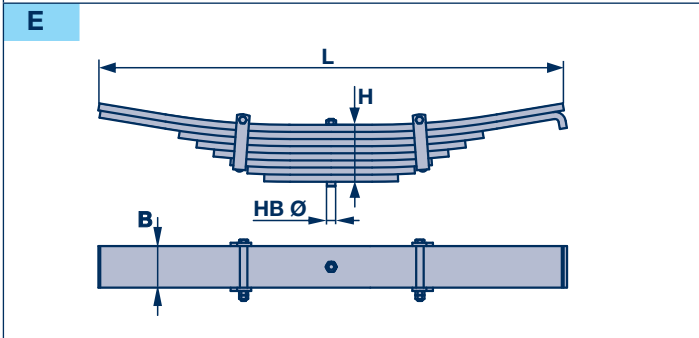
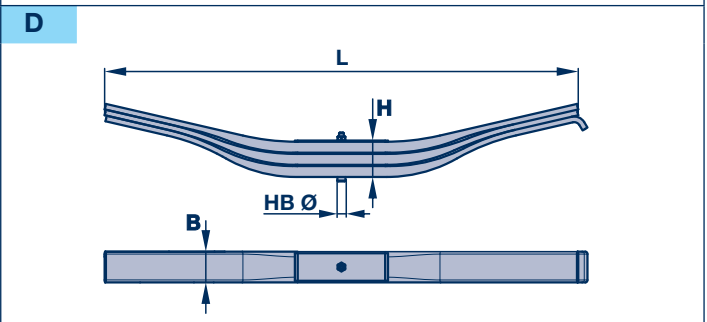
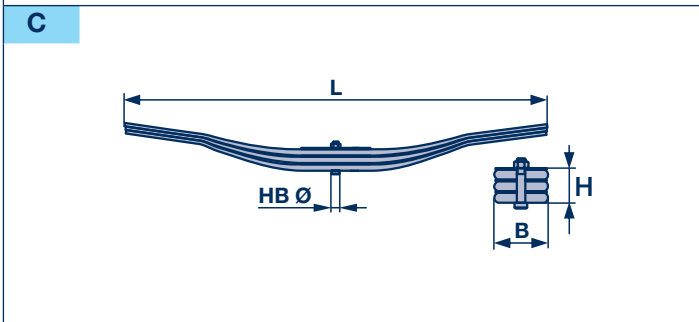
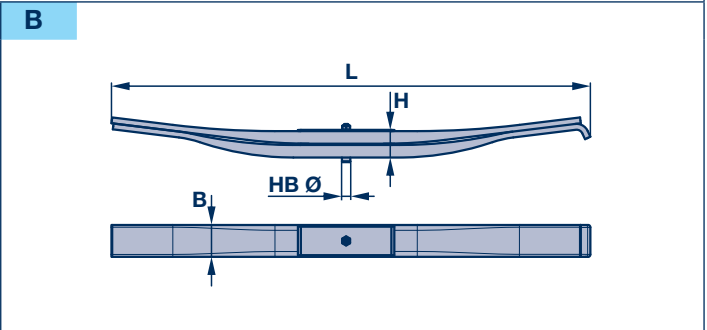
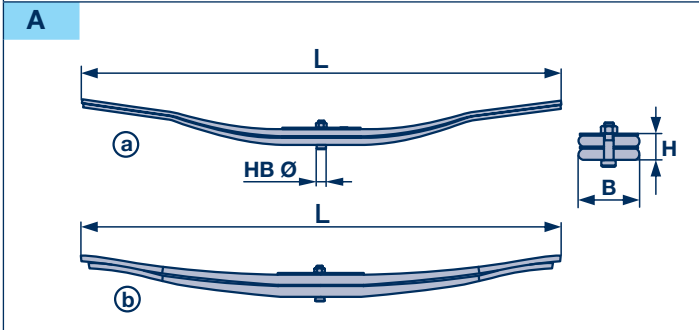
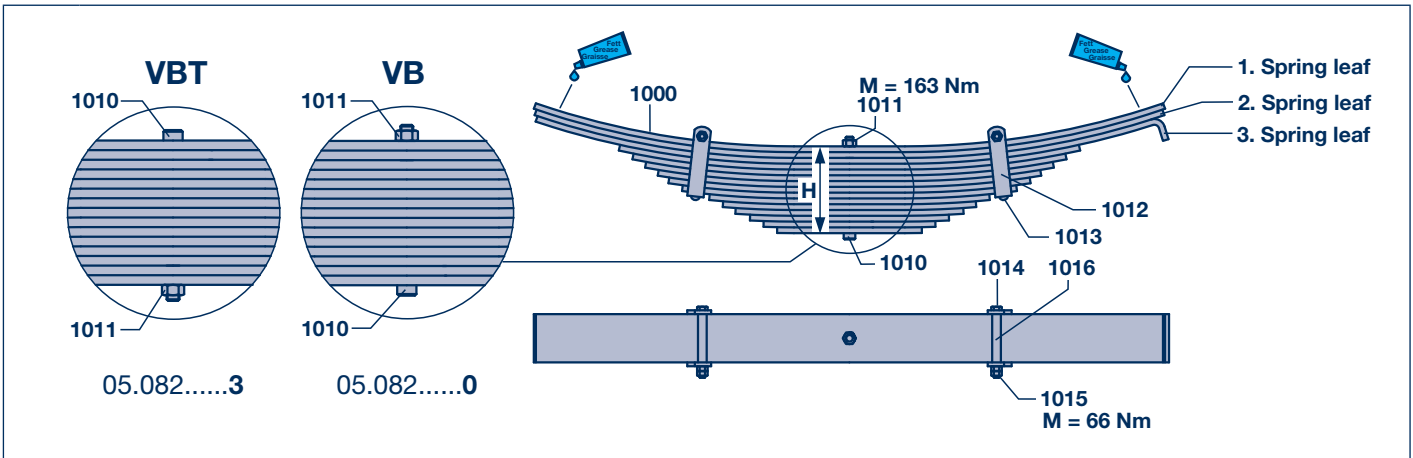



# Leaf springs 2

## Leaf springs, anti-vibration leaves 2.2

Qty. Layer	Wheel base	Axle load	Exec.	Fig.	L	H	B	HB Ø	BPW Code no. Leaf spring Item 1000	Spring leaves
2	1360 / 1500 / 2050	10 t	VB K / M	A a	1170	60	100	Ø 24	05.082.04.08.0	
			VBT K / M						05.082.04.08.3	
		12 t	VB K / M	A b	1170	60	100	Ø 24	05.082.04.06.0	
			VBT K / M						05.082.04.13.0	
	1310	12 t	VB K / M	A a	1170	64	100	Ø 24	05.082.04.13.3	
			VBT K / M						05.082.04.13.3	
			VB EC	B	1120	66	76	Ø 20	05.082.04.46.0	
3	1360 / 2050	9 t	VB K / M	C	1170	72	100	Ø 24	05.082.03.36.0	
			VBT K						05.082.03.36.3	
	1360 / 2050	10 t	VB K	C	1170	72	100	Ø 24	05.082.04.30.0 <sup>1)</sup>	
			VB EC						D	
8	1500	16 - 20 t	VB	E	1300	160	100	Ø 24	05.082.07.01.0	1. 02.1014.07.00 <sup>1)</sup>
			VBT						05.082.07.01.3	
9	1500 / 1600	18 - 20 t	VB	F	1300	180	100	Ø 24	05.082.08.07.0	1.+2. 02.1014.08.20
			VBT						05.082.08.07.3	
10	1360	9 t	VB EC	F	1170	120	76	Ø 20	05.082.04.45.0	1.+2. upon request
11	1360 / 1380 1410 / 2050	12 t	VB	F	1170	132	100	Ø 24	05.082.04.02.0	1.+2. 02.1014.04.10 3. 02.1014.04.11 4. 02.1014.04.12
			VBT						05.082.04.02.3	
	1360	12 t	VB EC	F	1170	143	76	Ø 20	05.082.04.44.0	1.+2. upon request
12	1360	14 t	VB	F	1170	144	100	Ø 24	05.082.05.03.0	1.+2. 02.1014.05.22
			VBT						05.082.05.03.3	
	1410	14 t	VB	F	1230	144	100	Ø 24	05.082.05.07.0	1.+2. 02.1014.05.50
			VBT						05.082.05.07.3	
13	1360 / 2050	9 - 10 t	VB	F	1170	130	100	Ø 24	05.082.03.02.0	1.+2. upon request
			VBT						05.082.03.02.3	
14	1360	16 t	VB	F	1170	168	100	Ø 24	05.082.06.01.0	1.+2. 02.1014.06.00
			VBT						05.082.06.03.0	
	1410	16 t	VB	F	1230	168	100	Ø 24	05.082.06.03.0	1.+2. 02.1014.06.25
			VBT						05.082.06.03.3	
	1500 / 2050	14 t	VB	F	1300	168	100	Ø 24	05.082.05.01.0	1.+2. 02.1014.05.09
			VBT						05.082.05.01.3	
1410	20 t	VB	F	1230	196	100	Ø 24	05.082.07.03.0	1.+2. auf Anfrage	
		VBT						05.082.07.03.3 <sup>1)</sup>		
15	1500	16 t	VB	F	1300	180	100	Ø 24	05.082.06.02.0	1.+2. auf Anfrage
			VBT						05.082.06.02.3	

Further leaf springs and spring leaves upon request.

### Anti-vibration leaves for 2- and 3-layer leaf springs

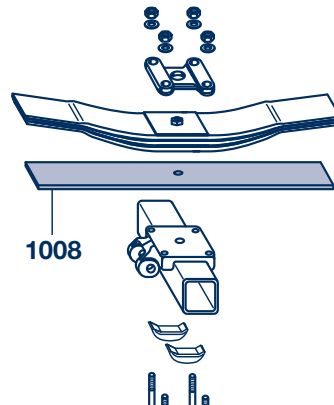
	Item	Designation	Dimension	BPW Code no.
		1008	Plate (WB 1310)	90 x 1190 x 5
		(WB 1360)	90 x 1230 x 5	03.281.39.01.0 <sup>1)</sup>

<sup>1)</sup> no longer available

# 2 Leaf springs

## 2.3 Spare parts for leaf springs

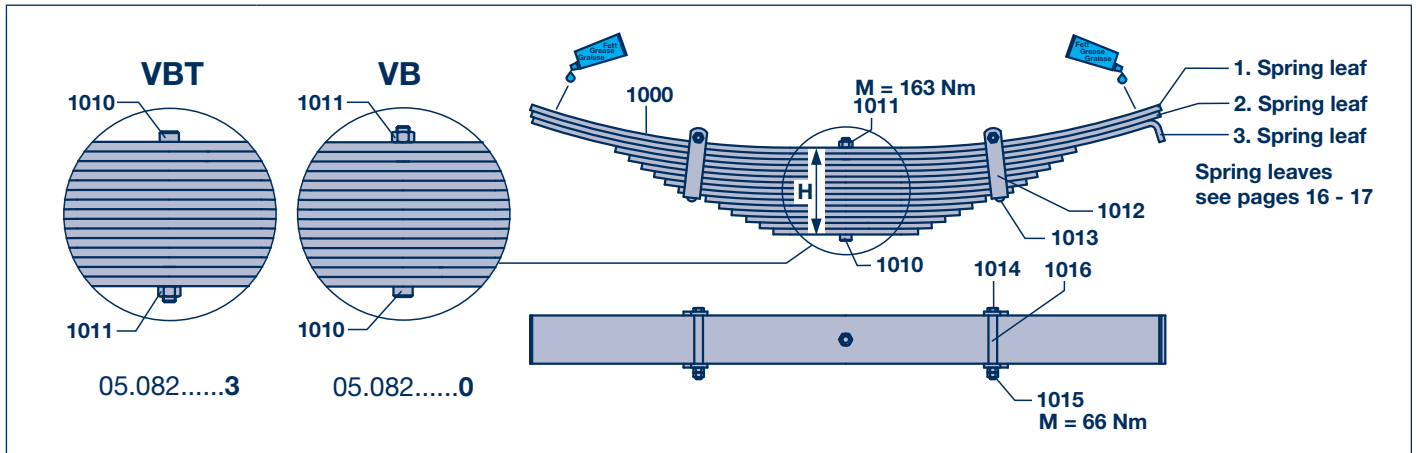

	Item	Designation	Leaf spring height H	HB Ø	d	L	BPW Code no.
	1010	Spring screw	54 / 60	Ø 24	M 16	75	03.341.02.14.0
			63 / 64			80	03.341.02.18.0
			66			80	upon request
			69 / 72	Ø 24	M 16	85	03.341.02.07.0
			80			90	03.341.02.02.0
			85			100	03.341.02.03.0
			90			105	03.341.02.17.0
			93			110	upon request
			95	Ø 24	M 16	110	03.341.02.18.0
			100			115	03.341.02.15.0
			112			120	03.341.02.30.0
			116			130	03.341.02.04.0
			120			135	03.341.02.32.0
			140 - 144	Ø 20	M 12	140	upon request
						145	02.5038.53.80 <sup>1)</sup>
			130	Ø 24	M 16	150	03.341.02.05.0
						160	upon request
			160 - 144	Ø 24	M 16	165	03.341.02.16.0
						160	185
168	190	03.341.02.25.0					
180	200	03.341.02.26.0					
196	215	03.341.02.28.0 <sup>1)</sup>					
1011	Hexagon nut	M 12 / 934-8				02.5202.	
		M 16 / 934-8				02.5202.20.80	
1012	Spring clamp			upon request			
1013	Button head rivet		12 x 28 / 124				
1014	Hexagon screw						
1015	Hexagon nut		M 12 / 934-8				
1016	Tube						

<sup>1)</sup> no longer available

---

# Notices

## 3 Axle beams

### Welding guidelines for axle beams

#### Welding guidelines for axle beams.

When fitting or repairing trailer axles it may be necessary to weld components onto the axle beam.

For that reason BPW axles are made of materials that can be welded. The axle beams do not have to be pre-heated before welding.

The carrying capacity and faultless operation of BPW axles are not impaired by welding, if the following points are complied with.

#### Welding process

- ⊙ Gas shielded arc welding  
Weld wire quality G 4 Si 1 – EN ISO 14341-A
- ⊙ Manual arc welding  
Stick electrodes E 46 5 B 32 H 5 – EN ISO 2560-A
- ⊙ Mechanical quality values must correspond to the basic material S 420 or S 355 J 2
- ⊙ Single sided fillet weld:  
Seam quality according to DIN EN ISO 5817  
Sheet thickness 6 mm -> Weld thickness a4 ▽  
Sheet thickness 8 mm -> Weld thickness a6 ▽
- ⊙ Avoid end craters and undercuts!
- ⊙ Functional areas free from weld spatter.

#### Miscellaneous

Do not alter the camber or tracking of the axles except within BPW tolerances.

Observe the welding zones and weld lengths shown in the adjacent diagram.

 **No welding must be carried out in the lower tensile zone of the axle beam!**

 For all welding activities, the springs, spring clamps and all other sensitive components must be protected against flying sparks and welding spatter.

The earth terminal must under no circumstances be attached to the leaf springs, spring U-bolts or hubs.

No welding at leaf springs!

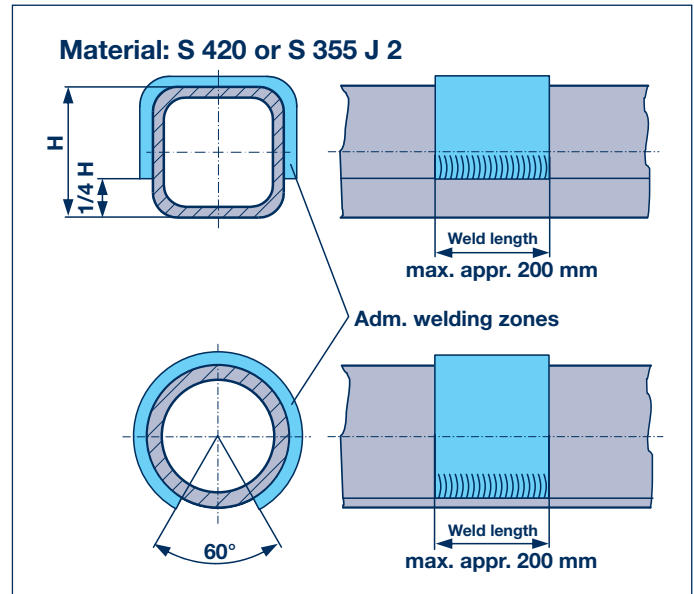

# Axle clampings 4

## General 4.1

### BPW Axle clampings

The axle is connected to the leaf spring using the axle connection comprising: spring plates, spring pads, segments and U-bolts.

In contrast to BPW air suspension systems (clamped), only welded axle assembly mountings are used with VB suspension units.

This means that the spring pads are welded to the axle beam.

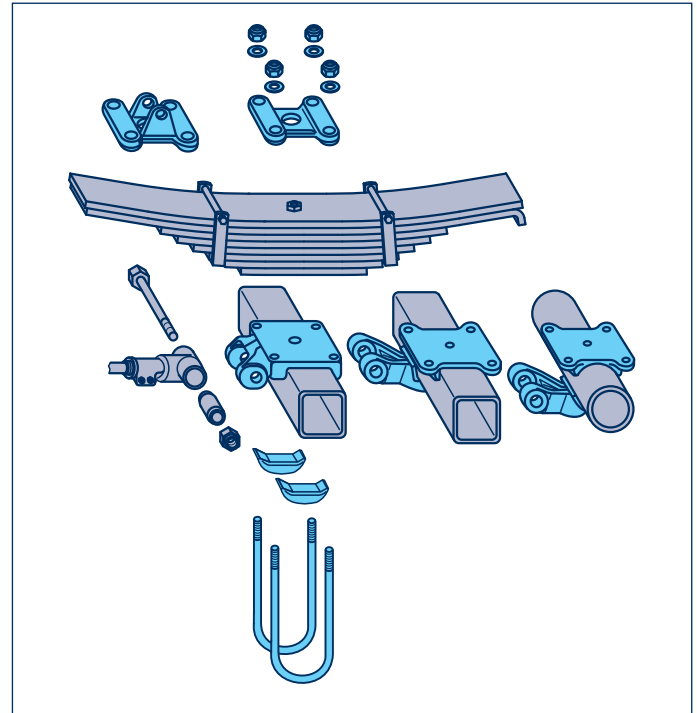

# 4 Axle clampings

## 4.2 Spring seats, supports

### Spring seats, supports

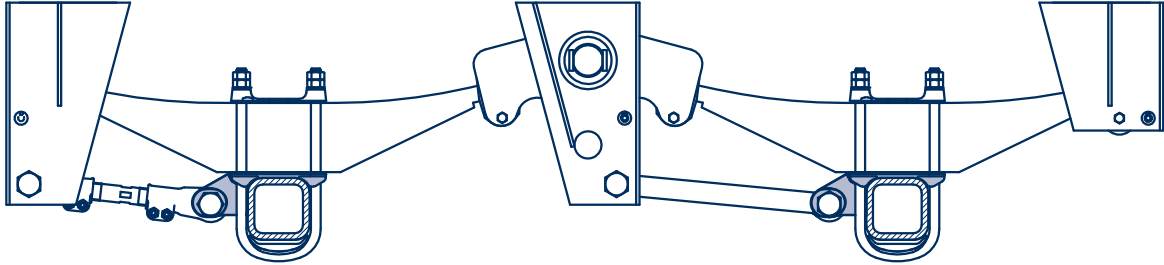

### VB ECO Cargo

**A**



**B**

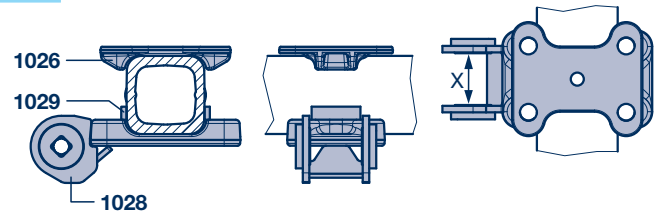

**VB**

**C**



**D**

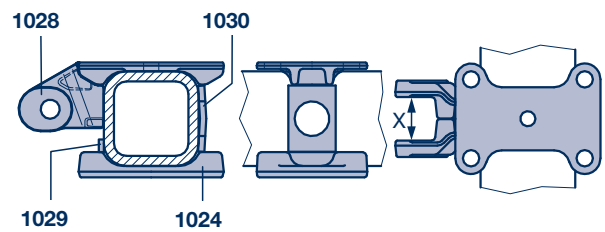

**E**

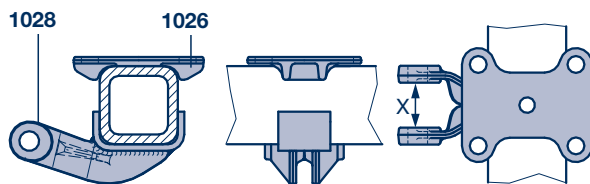

# Axle clampings 4

## Spring seats, supports 4.2

### Spring seats, supports

Spring seats, supports										
	Series	Item	Designation	Fig.	Axle beam	Brake position	X	Ø Attachment connecting rod	BPW Code no.	
<p><b>Axle series H. / R..</b></p> <p><b>Axle series K. / N..</b></p> <p><b>VB</b></p>	<b>VB ECO Cargo</b>	1028	Support	A	□ 120	16°	79	Ø 24	03.189.16.04.0	
						□ 150	25°	79	Ø 24	03.189.16.03.0
		1024	Spring seat, upper	B	□ 120	0°				03.032.18.26.0
		1028	Support					79	Ø 24	05.189.16.13.0
		1029	Plate							03.283.53.12.0
	<b>VB</b>	1028	Support	C	□ 120	30°	69	Ø 30	05.189.02.04.0	
					□ 150	25°	69	Ø 30	03.189.15.56.0	
					□ 150	25°	69	Ø 36	03.189.15.57.0	
		1024	Spring seat, lower	D	□ 120	30°			03.032.17.05.1	
		1028	Support				69	Ø 30	05.189.02.04.0	
		1029	Block						03.221.25.04.0	
		1030	Shaped plate						03.161.63.01.0	
		1024	Spring seat, lower	D	□ 150	25°			03.032.19.26.0	
		1028	Support				69	Ø 30	03.189.15.56.0	
							69	Ø 36	03.189.15.57.0	
							03.283.53.12.0			
							03.161.64.05.0			
	1026	Spring seat, upper	E	□ 120	0°			03.032.17.89.0		
	1028	Support				69	Ø 30	05.189.07.63.0		
	1026	Spring seat, upper	~E	Ø 127	0°			03.032.38.37.0		
	1028	Support				69	Ø 30	05.189.04.97.1		

\* The support (item 1028) can be aligned facing the front or the rear.  
Further types upon request.

### Packer

	1039	Plate	20 mm	03.281.96.26.0
			30 mm	03.281.96.19.0

# 4 Axle clampings

## 4.2 Spring seats, supports

### Spring seats, supports

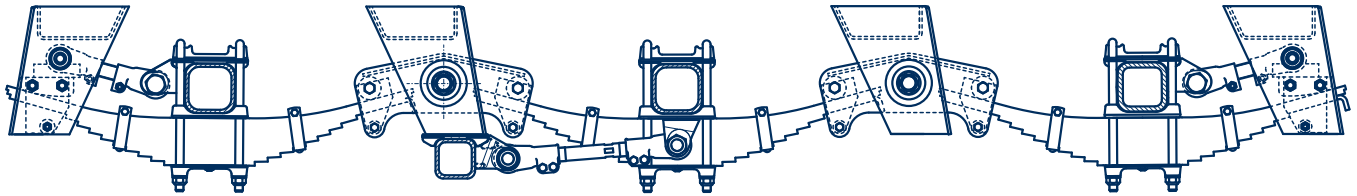

#### VBT

**F**

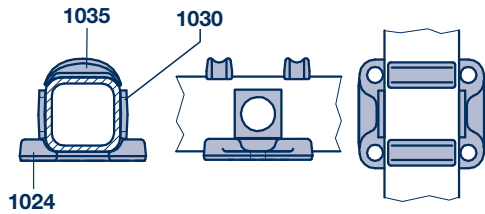

**G**

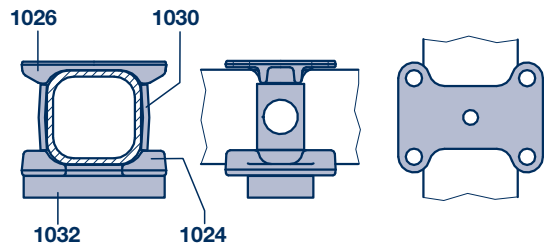

**H**

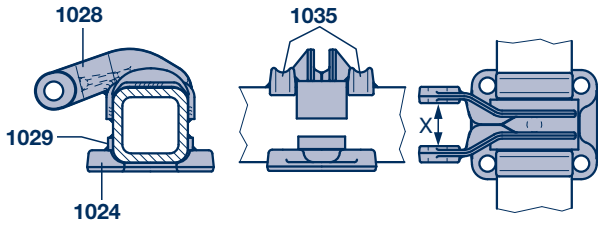

**I**

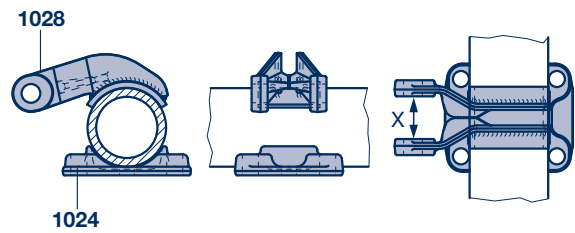

**J**

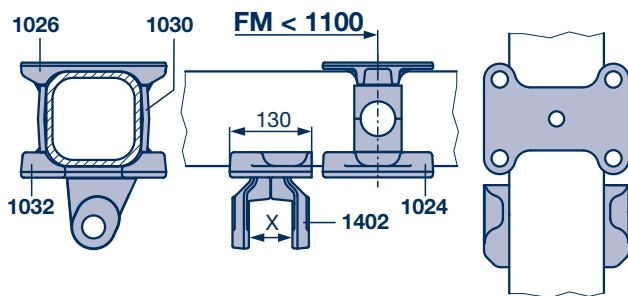

**K**

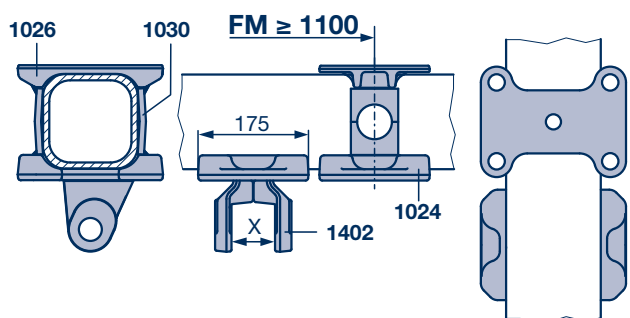



# Axle clampings 4

## Spring seats, supports 4.2

### Spring seats, supports

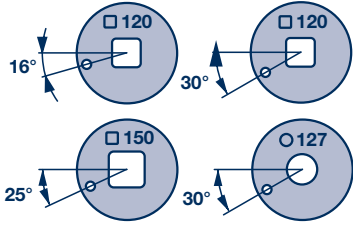
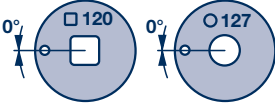
	Series	Item	Designation	Fig.	Axle beam	Brake position	X	Ø Attachment connecting rod	BPW Code no.	
<p><b>Axle series H.. / R..</b></p>  <p><b>Axle series K.. / N..</b></p> 	VBT	1024	Spring seat, lower	F	□ 120	16°		-	03.032.17.05.1	
		1030	Shaped plate							03.161.63.01.0
		1035	Segment							03.345.23.02.1
		1024	Spring seat, lower	F	□ 150	25°		-		03.032.19.26.0
		1030	Shaped plate							03.161.64.05.0
		1035	Segment							03.345.25.01.1
		1024	Spring seat, lower	G	□ 120	30°		-		03.032.17.89.0
		1026	Spring seat, upper							03.032.17.05.1
		1030	Shaped plate							03.161.63.01.0
		1032	Plate							03.281.96.19.0
		1024	Spring seat, lower	H	□ 120	0°				03.032.17.05.1
		1028	Support *				69	Ø 30		05.189.10.59.0
		1029	Plate							03.283.53.12.0
		1035	Segment							03.345.23.02.1
		1024	Spring seat, lower	I	Ø 127	0°				03.032.38.13.0
		1028	Support				69	Ø 30		05.189.10.58.0 <sup>1)</sup>
		1024	Spring seat, lower	J	□ 150	25°				03.032.19.26.0
		1026	Spring seat, upper							03.032.19.46.0
		1030	Plate							03.161.64.05.0
		1402	Support				69	Ø 36		05.189.03.52.0
1024	Spring seat, lower	K	□ 150	25°				03.032.19.26.0		
1026	Spring seat, upper							03.032.19.46.0		
1030	Plate							03.161.64.05.0		
1402	Support				69	Ø 36		05.189.02.69.0		

\* The support (item 1028) can be aligned facing the front or the rear.

<sup>1)</sup> no longer available

Further types upon request.

### Packer

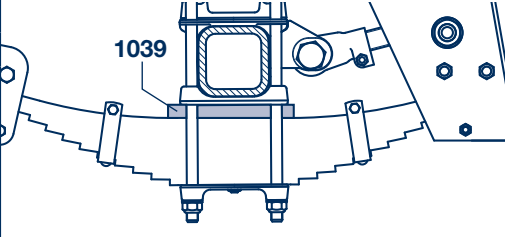
	1039	Plate	20 mm	03.281.96.26.0
			30 mm	03.281.96.19.0

# 4 Axle clampings

## 4.3 Spring plates, segments

### Spring plates

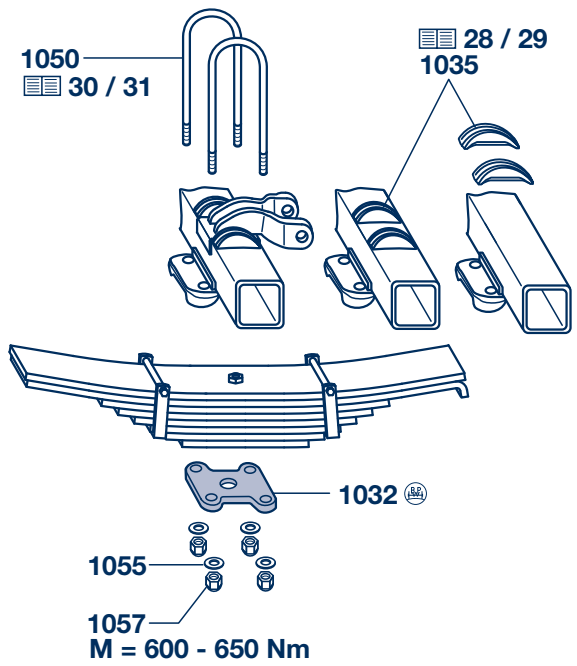
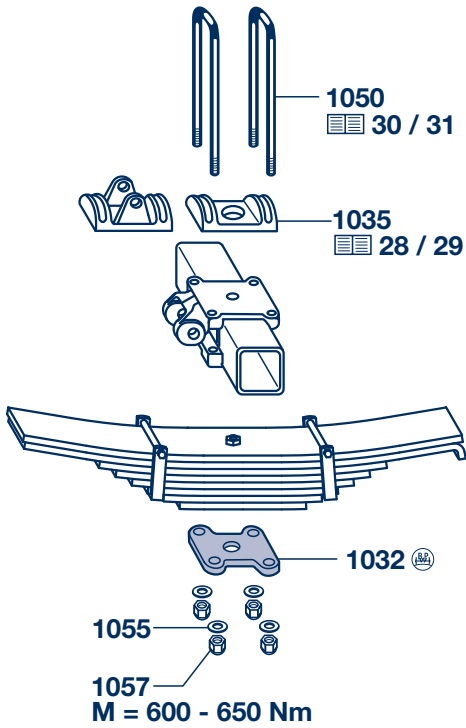
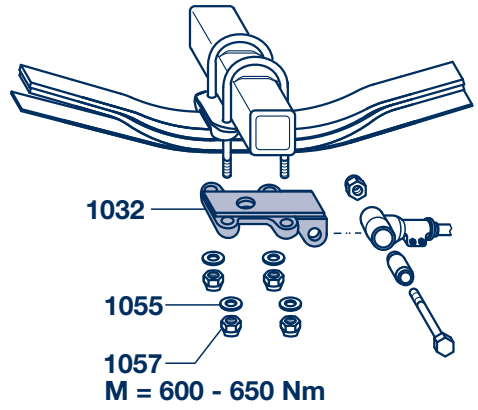
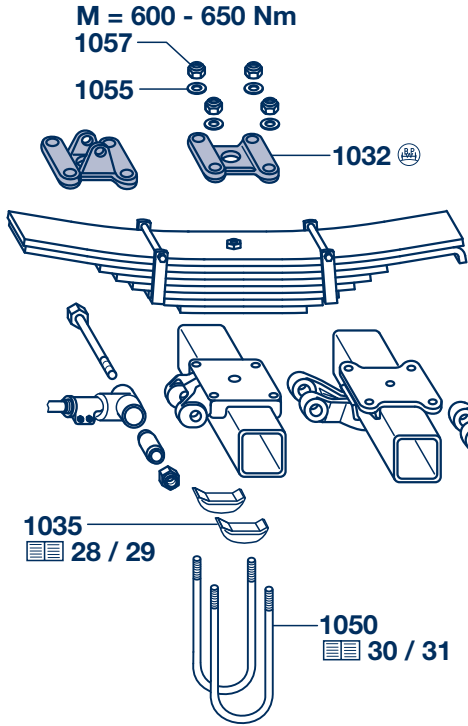

# Axle clampings 4

## Spring plates, segments 4.3

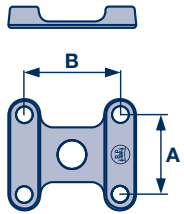
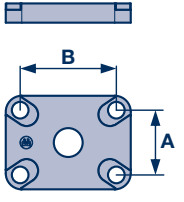
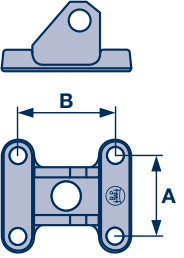
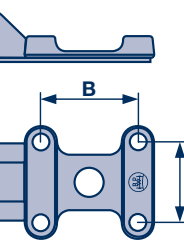
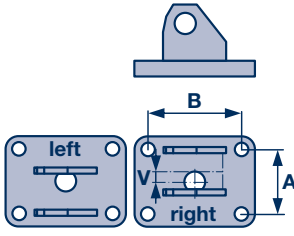
Spring plates							
	Item	Designation	Utilisation / Axle beam	Dimension			BPW Code no.
				A	B	V	
<b>Without U-stabilizer</b>							
	1032	Spring plate	□ 120	125	150	-	03.145.22.01.0
			□ 120 <b>VB ECO Cargo</b>	101	150		03.145.25.27.0
			∅ 127	125	180		03.145.22.06.0 <sup>1)</sup>
			□ 150 <b>VB ECO Cargo</b>	101	180		03.145.23.32.0
			□ 150	125	155		03.145.23.27.0
	1032	Spring plate	□ 120 <b>VB ECO Cargo</b>	101	150	-	03.145.25.28.0
<b>Spring plate for U-stabilizer attachment / connecting rod attachment</b>							
	1032	Federplatte	□ 120	125	150	-	05.145.22.05.0
			□ 150		180		05.145.23.08.0
			∅ 127		155		05.145.22.20.0 <sup>1)</sup>
	1032	Spring plate	□ 120	125	150	-	05.145.22.04.0
			□ 150		180		05.145.23.05.0
	1032	Spring plate, right	□ 150	125	180	10	05.145.23.24.0 <sup>1)</sup>
	1033	Spring plate, left				20	05.145.23.21.0 <sup>1)</sup>
						10	05.145.23.25.0 <sup>1)</sup>
							20

<sup>1)</sup> no longer available

# 4 Axle clampings

## 4.3 Spring plates, segments

### Spring plates, segments

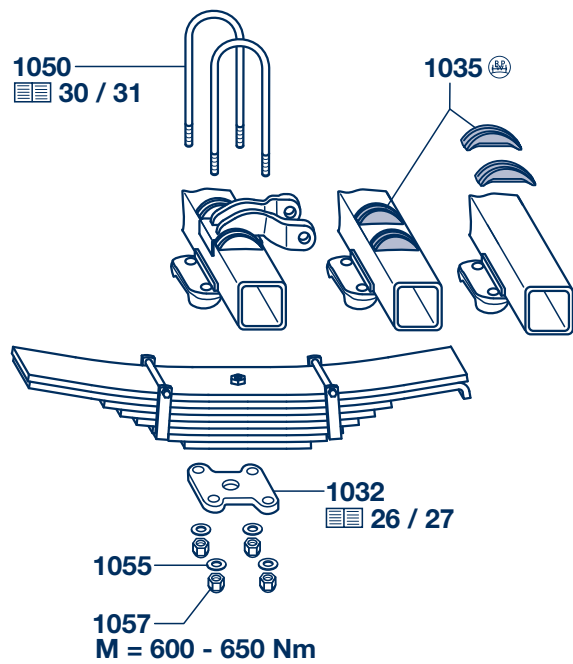
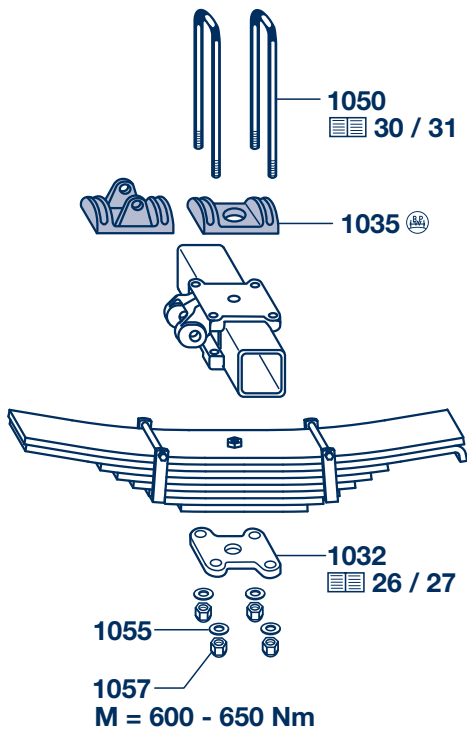
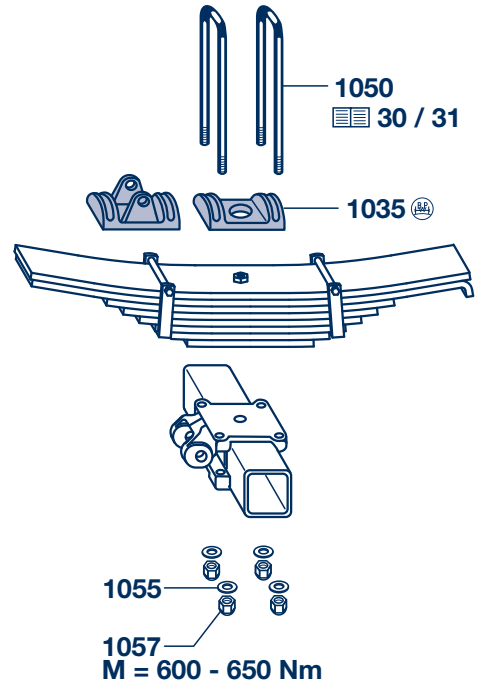
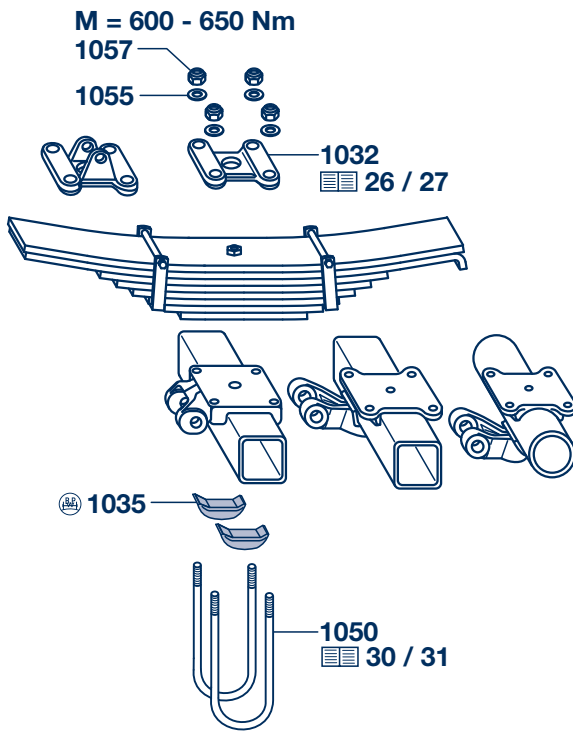

# Axle clampings 4

## Spring plates, segments 4.3

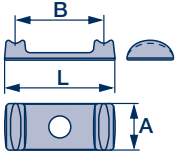
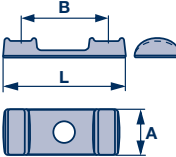
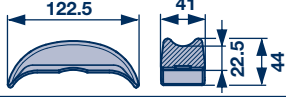
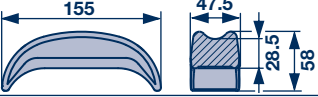
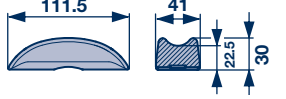
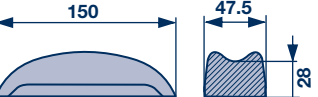
Spring plates, segments							
	Item	Designation	Utilisation / Axle beam	Dimension			BPW Code no.
				A	B	L	
<b>Double segment</b>							
	1035	Spring plate	<input type="checkbox"/> 120	95	150	195	03.145.10.39.0
			<input type="checkbox"/> 150		180	225	03.145.10.40.0
	1035	Spring plate	<input type="checkbox"/> 120 / <input type="checkbox"/> 150	95	150 / 180	225	03.145.10.08.0 *
			* no longer available, replaced by 10.39.0 / 10.40.0 (see above)				
<b>Segments</b>							
<b>Single segment on the axle beam</b>							
	1035	Segment	<input type="checkbox"/> 120				03.345.23.02.1
			<input type="checkbox"/> 150				03.345.25.01.1
	1035	Segment (welded on axle beam)	<input checked="" type="checkbox"/> 120 solid				03.345.23.03.0
			<input checked="" type="checkbox"/> 150 solid				03.345.25.04.0 <sup>2)</sup>
	1035	Segment <sup>1)</sup>	<input type="checkbox"/> 120				03.345.23.09.0
			<input type="checkbox"/> 150				
	1035	Segment <sup>1)</sup>	<input type="checkbox"/> 120				03.345.23.09.0
			<input type="checkbox"/> 150				

<sup>1)</sup> for flattened spring U-bolts (disc brake)

<sup>2)</sup> no longer available

# 4 Axle clampings

## 4.4 Spring U-bolts

### Spring U-bolts

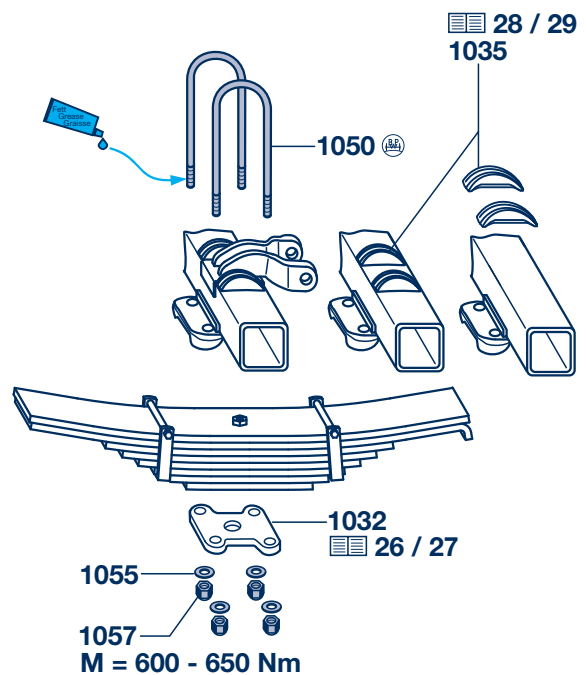
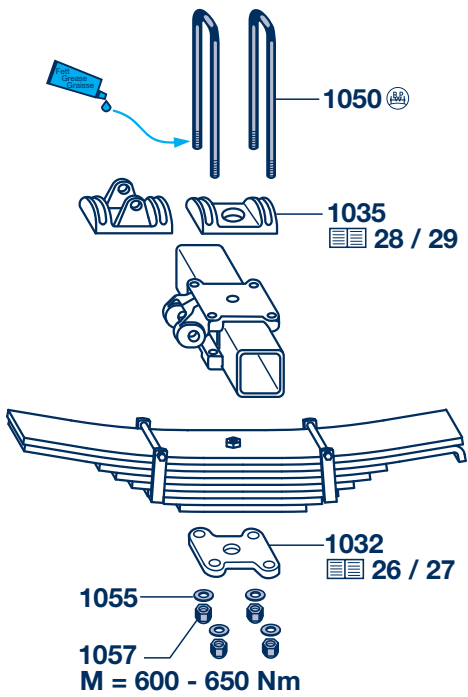
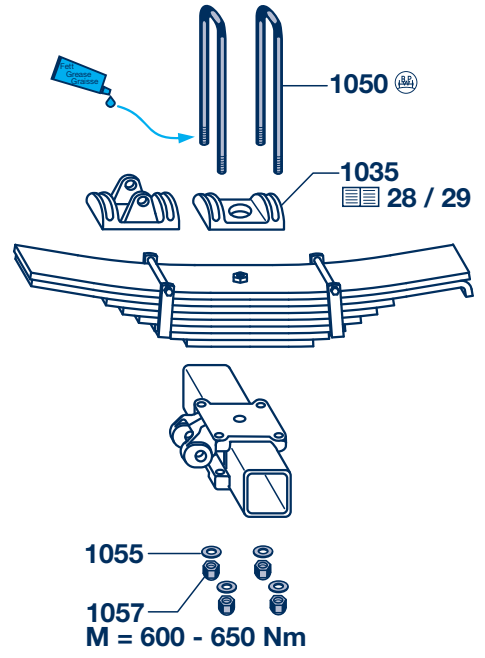
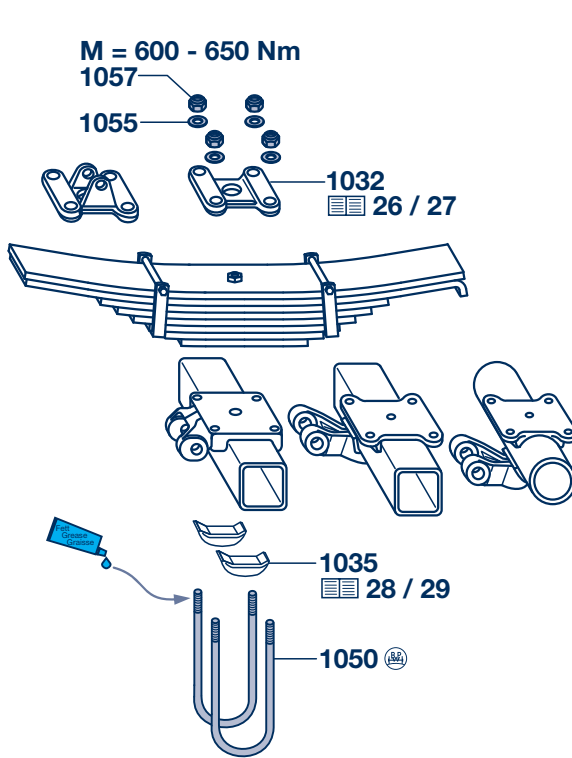

# Axle clampings 4

## Spring U-bolts 4.4

### Spring U-bolts

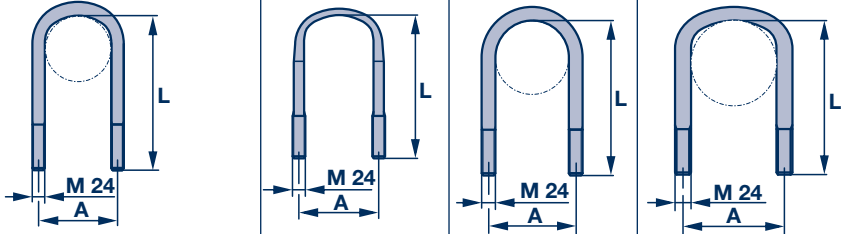
Item	Designation	Dimension	BPW Code no.				
							
		<b>L</b>	<b>A = 125</b> Leaf spring width 100 mm	<b>A = 152</b> □ 120	<b>A = 152</b> Disc brake □ 120	<b>A = 152</b> Ø 127	<b>A = 180</b> □ 150
1050	Spring U-bolt	190		03.138.41.31.4			
		210	03.138.44.17.4	03.138.41.32.4			
		230	03.138.44.21.4				
		250					03.138.45.20.4
		255	03.138.44.14.4				
		265				03.138.41.20.4	
		270	03.138.44.19.4	03.138.41.01.4			
		275				03.138.41.21.4	
		280	03.138.44.08.4	03.138.41.19.4		03.138.41.18.4	
		290	03.138.44.16.4	03.138.41.17.4		03.138.41.14.4	
		300	03.138.44.04.4	03.138.41.13.4	03.138.41.34.4		
		310	03.138.44.09.4	03.138.41.16.4		03.138.41.11.4	
		320	03.138.44.15.4	03.138.41.08.4	03.138.41.35.4	03.138.41.22.4	03.138.45.11.4
		330	03.138.44.02.4	03.138.41.26.4			03.138.45.09.4
		335				03.138.41.10.4	
		340	03.138.44.18.4				03.138.45.19.4
		345		03.138.41.05.4	03.138.41.36.4		
		350					03.138.45.08.4
		355	03.138.44.01.4	03.138.41.23.4		03.138.41.09.4	
		360					03.138.45.07.4
		365		03.138.41.06.4			
		370	03.138.44.12.4			03.138.41.15.4	
		380					03.138.45.06.4
		385	03.138.44.03.4	03.138.41.07.4			
		390				03.138.41.04.4	
		400	03.138.44.25.4	03.138.41.02.4			03.138.45.03.4
		405		03.138.41.12.4			
		410	03.138.44.10.4			03.138.41.24.4	
		420	03.138.44.11.4				03.138.45.04.4
		435	03.138.44.06.4	03.138.41.29.4			
		440				03.138.45.05.4	
		452	03.138.44.07.4				
		460				03.138.45.10.4	
		470	03.138.44.20.4				
		485				03.138.45.12.4	
		490	03.138.44.13.4				
		495				03.138.45.13.4	
		520				03.138.45.16.4	
1055	Washer		02.5401.25.07 Ø 25 / 125				
1057	Hexagon nut (16x)		02.5202.30.10 M 24 / 934-10 replaced by 02.5220.74.12				
1057	Lock nut (8x)		02.5220.74.12 VM 24 / 980-10				

## 5 Connecting rods

### 5.1 General

#### General

The horizontal alignment of BPW connecting rods guarantees precise axle location.

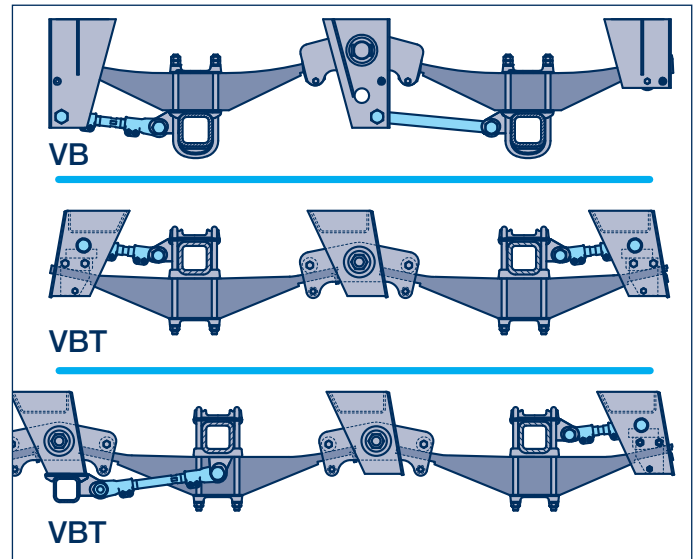

#### Tracking adjustment (VB up to 08/2013 + VB Heavy duty)

One rigid and one adjustable connecting rod enable slight adjustment of the tracking of the axles on the suspension unit.

Two adjustable connecting rods are used for each axle in the case of some suspension unit designs.

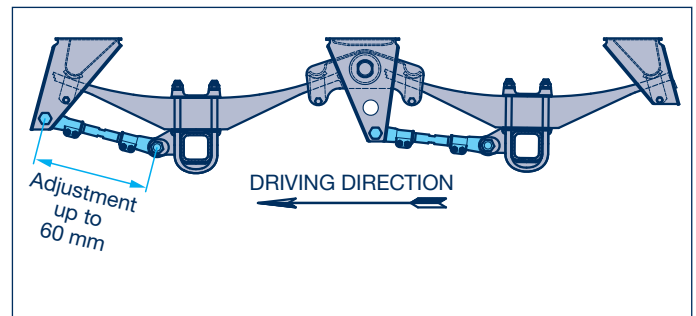

Fig. with adjustable connecting rod

#### Tracking adjustment (VB ECO Cargo)

Suspension axles can be quickly aligned through **VB ECO Cargo** hanger brackets and equalizing beams with integrated wheel alignment:

Production tolerances on the vehicle can be equalised or wheelbases corrected (axle tracking), see also installation information (04.00.547110).

Make sure that the adjusting plates (arrows) on the bracket are correctly seated, make sure that inner and outer adjusting plates of a bracket are set symmetrically!

The square on the spring bolt head (anti-rotation lock) must sit in the slot of the adjusting plate.

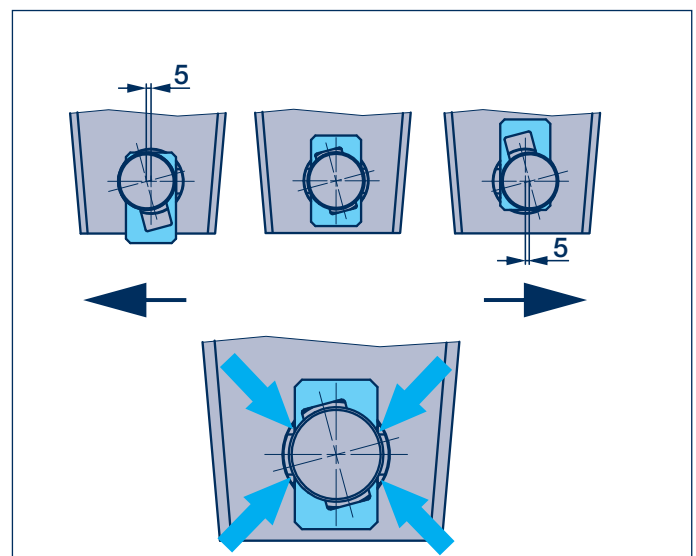

Track adjusting with **VB ECO Cargo**



# Connecting rods 5

## General 5.1

### Rubber-steel bushes

The rubber-steel bushes pressed into the connecting rods guarantee a low-maintenance mounting.

Ø Screw	Outer Ø Bush	Inner Ø Connecting rod
Ø 24	Ø 60/68	Ø 55
Ø 30	Ø 60	Ø 55
Ø 36	Ø 66	Ø 62

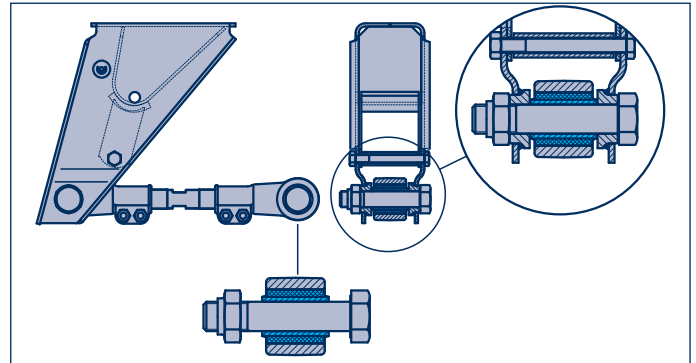

### Changing bushes

The bushes in the connecting rods can either be pressed in and out under a press (a), or changed under the vehicle with the BPW installation device (b).

When replacing the bushes it is important to ensure that they project evenly on both sides (arrows) after assembly.

#### Tool for pressing bushes in under a press.

Ø 24 / 60 BPW Code no. **15.009.19433 VB EC**

Ø 30 / 60 BPW Code no. **15.003.19433**

Ø 36 / 66 BPW Code no. **15.004.19433**

#### Tool for manual fitting

Ø 60 BPW Code no. **14.825.11744**

**Apply soapy water or another lubricant to the bushes before fitting them.**

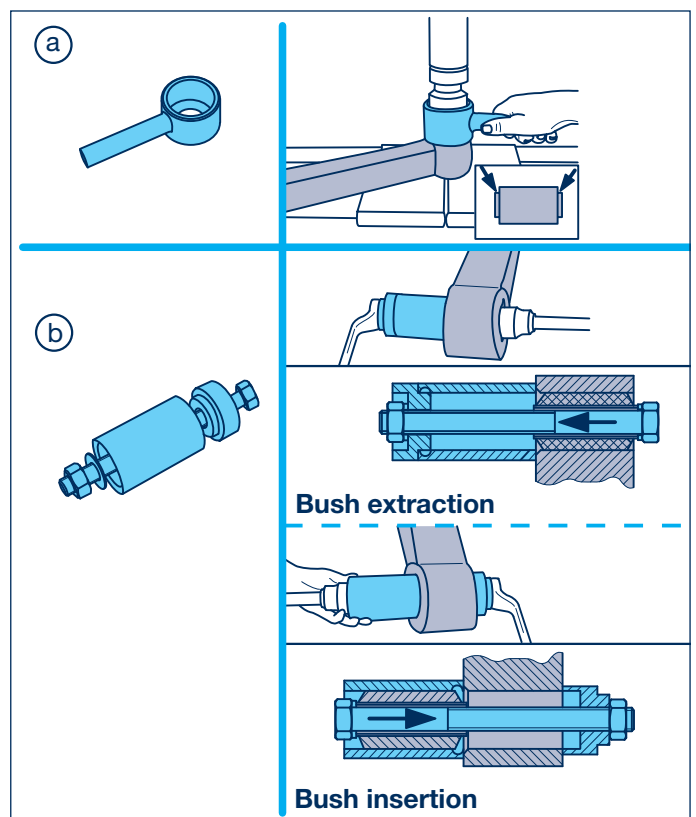

### Connecting rod attachments

The connecting rods are attached to the axle beams, connecting pieces and equalising beams using hexagon bolts.

Where there is an offset equalising beam (for steering axles) a threaded rod is used with a spacer tube.

Reducing sleeves can be used for the attachment of Ø 36 connecting rods with M 30 bolts (see attachments).

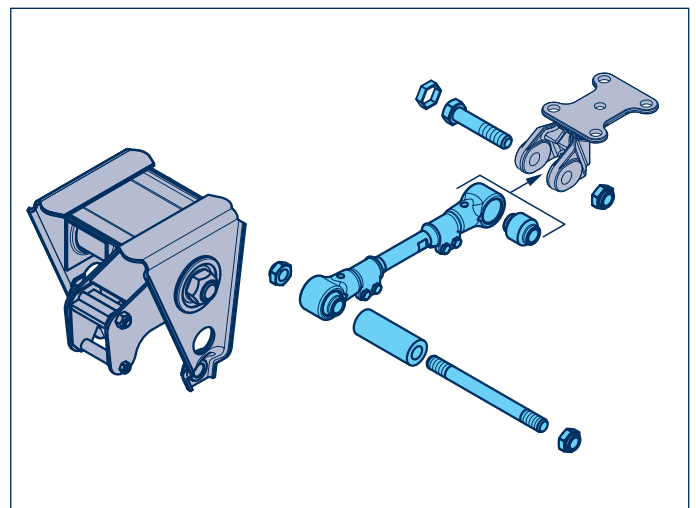

# 5 Connecting rods





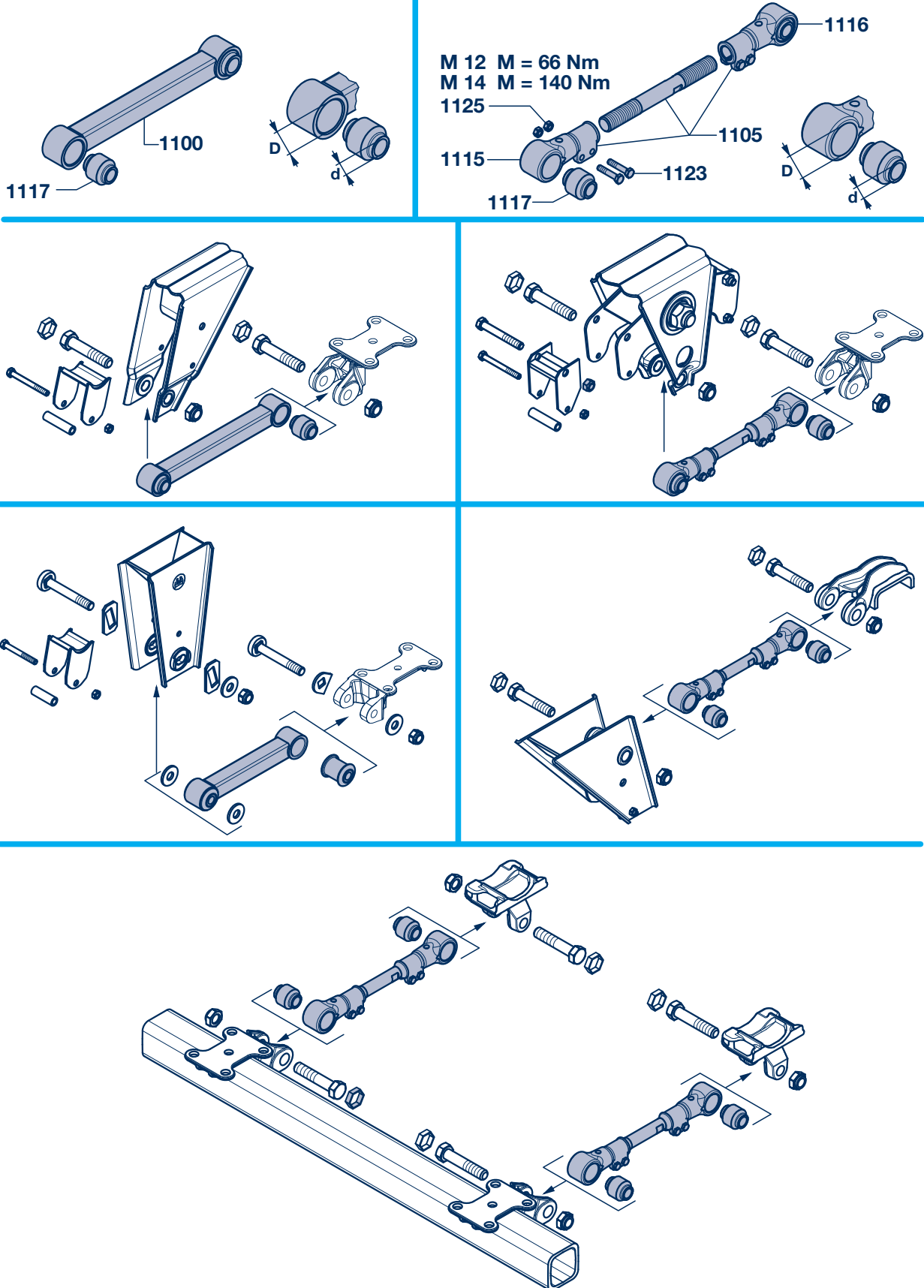

## 5.2 Connecting rods, spare parts

### Connecting rods, spare parts

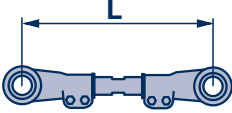

# Connecting rods 5

## Connecting rods, spare parts 5.2

Connecting rods, spare parts															
															
Connecting rod, fixed Item 1100 (incl. item 1117)		Connecting rod, adjustable Item 1105 (incl. item 1115 - 1125)		Dimension		Tensioner head, left threaded Item 1115	Tensioner head, right threaded Item 1116	Bush Item 1117							
L	BPW Code no.	L	BPW Code no.	d	D	BPW Code no.	BPW Code no.	BPW Code no.							
330	05.443.49.83.0	-	-	24	55	-	-								
355	05.443.49.80.0	-	-												
500	05.443.49.84.0	-	-												
520	05.443.49.79.0	-	-												
535	05.443.49.85.0	-	-												
640	05.443.49.81.0	-	-												
750	05.443.49.82.0	-	-												
330	05.443.44.07.0 <sup>2)</sup>	-	-	30	55	03.353.67.04.0	03.353.67.05.0								
360	05.443.45.21.0	320 - 380	05.443.70.92.0 <sup>2)</sup>												
425	05.443.46.06.0 <sup>2)</sup>	410 - 450	05.443.70.14.1 <sup>1)</sup>												
440	05.443.46.04.0 <sup>2)</sup>	410 - 470	05.443.70.43.0 <sup>2)</sup>												
450	05.443.47.19.0 <sup>2)</sup>	430 - 480	05.443.71.15.0 <sup>2)</sup>												
475	05.443.47.15.0	450 - 500	05.443.70.77.0												
505	-	475 - 535	05.443.70.83.0												
535	-	515 - 555	05.443.70.19.1 <sup>1) 2)</sup>												
545	05.443.48.15.0	510 - 560	05.443.70.98.0												
575	-	550 - 600	05.443.71.10.0 <sup>2)</sup>												
705	05.443.49.31.0	680 - 730	05.443.71.18.0 <sup>2)</sup>												
820	05.443.49.32.0	790 - 840	05.443.71.19.0												
880	-	860 - 900	05.443.71.37.0 <sup>1) 2)</sup>												
300	05.443.44.06.0	285 - 315	05.443.71.12.0 *							36	62	03.353.68.05.0 *	03.353.68.06.0 *		
345	05.443.44.08.0	335 - 360	05.443.71.06.0									03.353.68.01.0	03.353.68.02.0		
370	05.443.48.37.0	355 - 385	05.443.71.57.0	* with only one hexagon screw (M 14 x 65) per tensioner head (no longer available)											
395	05.443.48.33.0	380 - 410	05.443.71.55.0												
425	05.443.46.03.0	410 - 440	05.443.71.04.0												
440	05.443.48.31.0	425 - 455	05.443.71.54.0												
445	05.443.48.39.0	430 - 460	05.443.71.58.0												
450	05.443.47.20.0 <sup>2)</sup>	435 - 465	05.443.71.02.0 <sup>2)</sup>												
470	05.443.48.35.0	455 - 485	05.443.71.56.0												
495	05.443.48.18.0 <sup>2)</sup>	480 - 510	05.443.71.08.0												
515	05.443.48.29.0	485 - 545	05.443.70.94.0												
515	-	485 - 545	05.443.71.33.0 <sup>1)</sup>												
575	05.443.48.27.0 <sup>2)</sup>	545 - 600	05.443.71.09.0												
575	-	545 - 600	05.443.70.86.0 <sup>1)</sup>												
770	05.443.49.36.0 <sup>2)</sup>	755 - 785	05.443.71.07.0												
785	-	755 - 815	05.443.71.22.0 <sup>1)</sup>												
Item	Designation	Dimension				BPW Code no.		Utilisation							
1123	Hexagon screw	M 12 x 60				02.5021.76.82		for d = Ø 30							
		M 14 x 65				02.5022.03.80		for d = Ø 36							
1125	Lock nut	M 12-8				02.5273.12.82		for d = Ø 30							
		M 14-8				02.5273.14.82		for d = Ø 36							

<sup>1)</sup> for VBT, incl. bushes, attachment screws and lock nuts

<sup>2)</sup> no longer available

# 5 Connecting rods

## 5.3 Connecting rod attachments, straight equalizing beam

### Connecting rod attachments, VB ECO Cargo, M 24

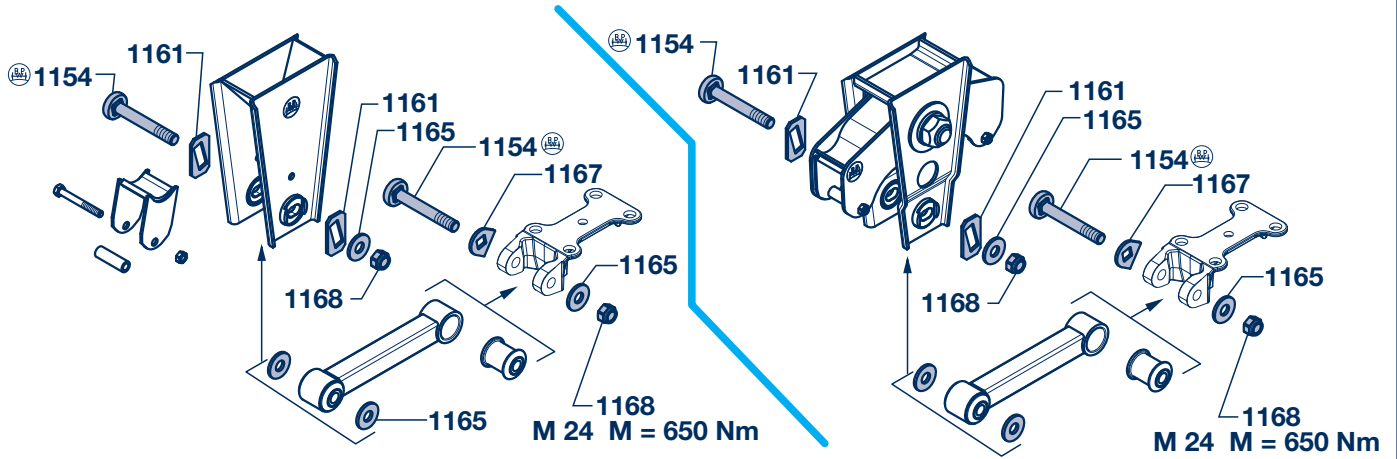

### Connecting rod attachments, VB / VBT, M 30 / M 36

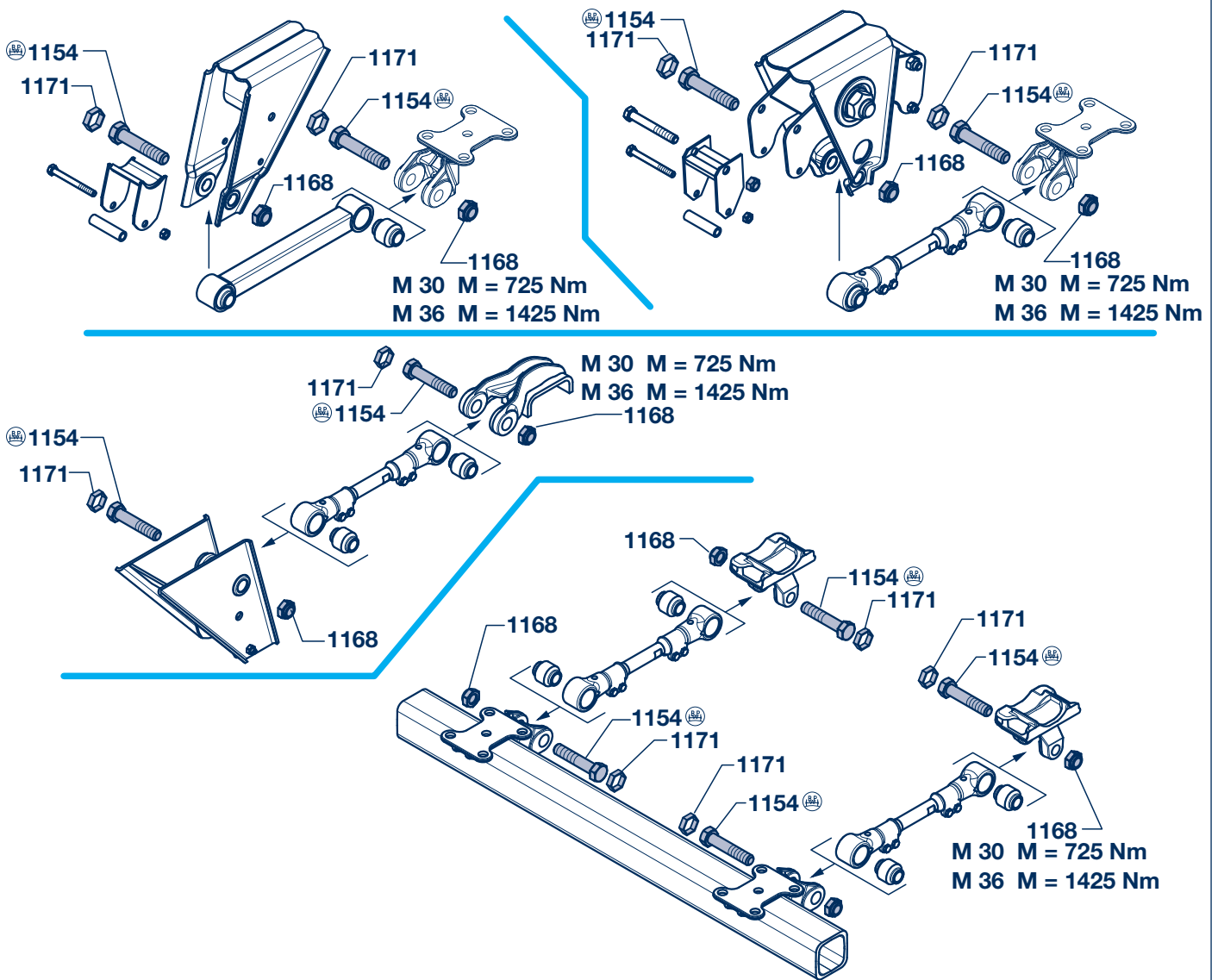

# Connecting rods 5

## Connecting rod attachments, straight equalizing beam 5.3

### Connecting rod attachments

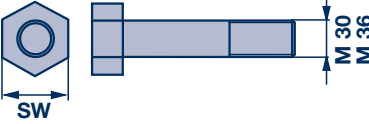
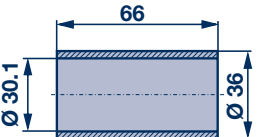
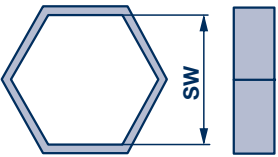
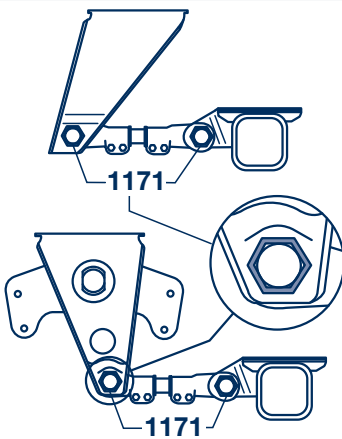
	Item	Designation	Dimension	BPW Code no.
<b>Attachment at hanger bracket or straight equalizing beam with track adjustment (VB ECO Cargo), M 24</b>				
	1154	Screw	M 24 x 171 / Ø 56	03.340.14.33.0
	1161	Plate (Adjusting plate)	98 x 51.5 x 6	03.281.44.25.0
	1165	Washer	Ø 25 / 60 x 6	03.320.33.28.0
	1167	Plate (Torsion protection)	60 x 60 x 6	03.281.43.17.0
	1168	Lock nut	M 24 / SW 36	03.260.14.13.0
<b>Attachment at hanger bracket or straight equalizing beam VB / VBT, M 30 / M 36</b>				
	1154	Screw	M 30 x 130 / SW 46	03.340.15.26.0
	1155		M 30 x 150 / SW 46	03.340.15.15.0
	1156		M 30 x 160 / SW 46	03.340.15.21.0
			M 30 x 170 / SW 46	03.340.15.24.0
			M 30 x 210 / SW 46	03.340.15.23.0
			M 36 x 155 / SW 55	03.340.16.03.0
			M 36 x 185 / SW 55	03.340.16.04.0
	M 36 x 215 / SW 55	03.340.16.05.0		
	1168	Lock nut	M 30 / 980-06 / SW 46	03.260.15.01.0
			M 36 / 980-06 / SW 55	02.5220.85.26
<b>Reducing sleeves for the attachment of Ø 36 connecting rods with M 30 bolts</b>				
	1160	Bush	Ø 30.1 / 36 x 66	03.112.12.17.0
<b>Torsion protection</b>				
	1171	Profiled part	SW 46	03.001.14.15.0
			SW 55	03.001.14.30.0
				

## 5 Connecting rods

### 5.3 Connecting rod attachments, equalizing beam with offset

#### Connecting rod attachments, equalizing beam with offset

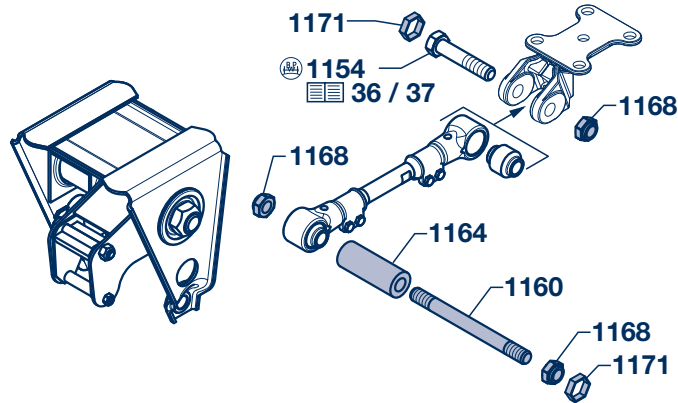

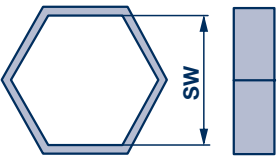
	Item	Designation	Fig.	Dimension	BPW Code no.
<b>Equalizing beam with offset (with steering axles)</b>					
	1160	Screw		M 30 x 310	03.340.75.23.0
				M 30 x 340	03.340.75.24.0 <sup>1)</sup>
				M 30 x 350	03.340.75.19.0
				M 30 x 392	03.340.75.18.0 <sup>1)</sup>
				M 36 x 400	03.340.76.46.0
	1164	Tube		Ø 31 / 60 x 130	03.300.74.51.0 <sup>1)</sup>
				Ø 31 / 60 x 160	03.300.74.93.0
				Ø 38 / 70 x 146	03.300.75.45.0 <sup>1)</sup>
	1168	Lock nut		M 30 / 980-06 / SW 46	03.260.15.01.0
				M 36 / 980-06 / SW 55	02.5220.85.26
<b>Torsion protection</b>					
	1171	Profiled part		SW 46	03.001.14.15.0
				SW 55	03.001.14.30.0

<sup>1)</sup> no longer available

---

# Notices

## 6 Front hanger brackets

### 6.1 General

#### General

The front connecting pieces welded onto the vehicle chassis are connected to the first axle of the suspension unit by means of connecting rods, thus conveying all the tracking, braking and acceleration forces from the axle into the vehicle chassis.

Adjustable connecting rods are fitted on one side to ensure easy tracking of the vehicle.

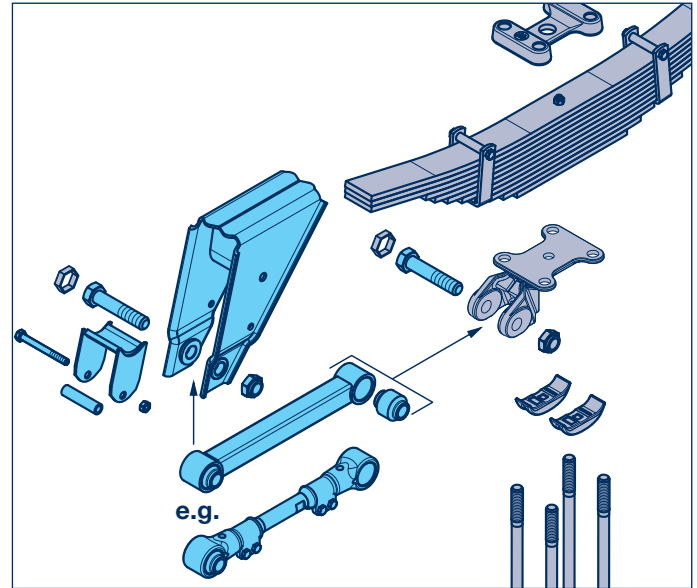

Suspension axles can be quickly aligned through **VB ECO Cargo** hanger brackets with integrated wheel alignment: Production tolerances on the vehicle can be equalised or wheelbases corrected (axle tracking), see also installation information (04.00.547110).

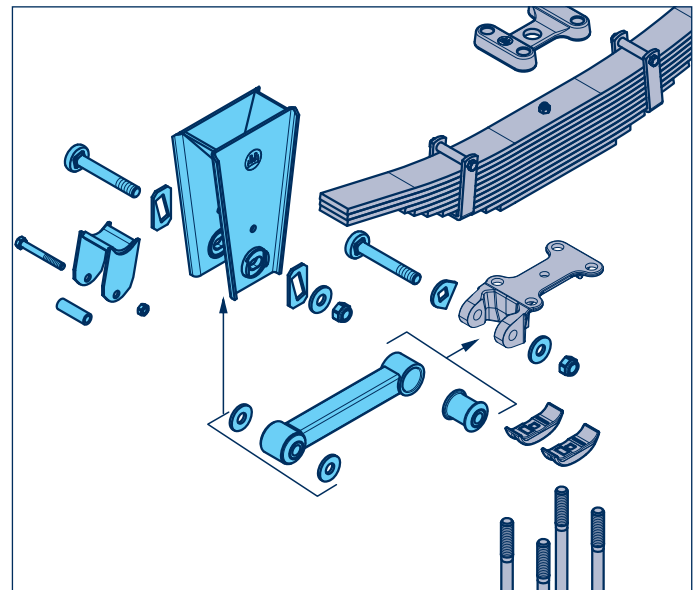

#### Sliders

The ends of the leaf spring are slide-mounted in the connecting pieces by means of screwed-in sliders or welded-in retainers made of hardened steel alloy.

In this context it should be ensured that the sliding points are always well greased.

Thick-walled lateral wear plates ensure precise guidance of the spring ends in the connecting pieces.

Note the correct position of the retainers when replacing them (see also equalising beams, page 47 and rear hanger brackets, page 62) !

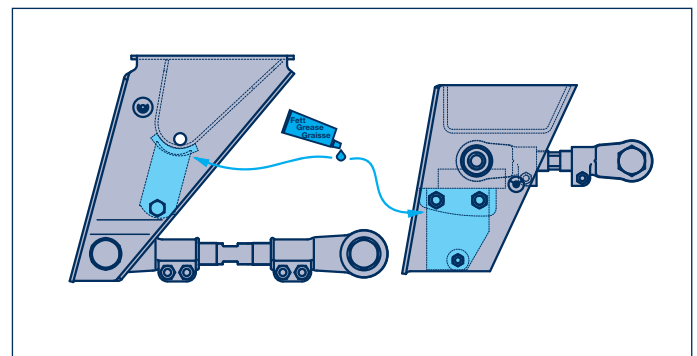



# Front hanger brackets 6

## General 6.1

### Drawbar connection

VB connecting pieces with integrated drawbar connection have 2 or 4 welded-in bushes, depending on the design, to take the attachment bolts.

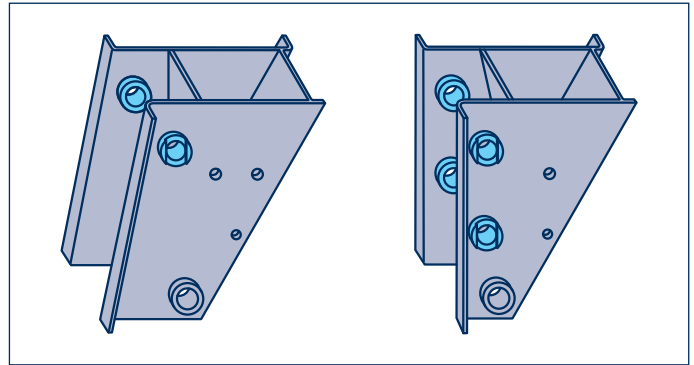

### BPW Code number

The BPW code number is stamped into the manufacturer's nameplate on the connecting piece.

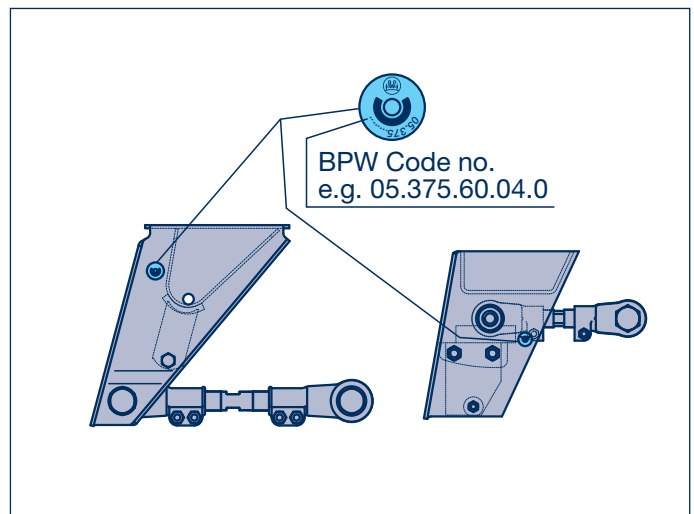

**VB ECO Cargo** hanger brackets with integrated wheel alignment are provided with a type plate on each bracket. It shows the name, BPW code number and the date of manufacture.

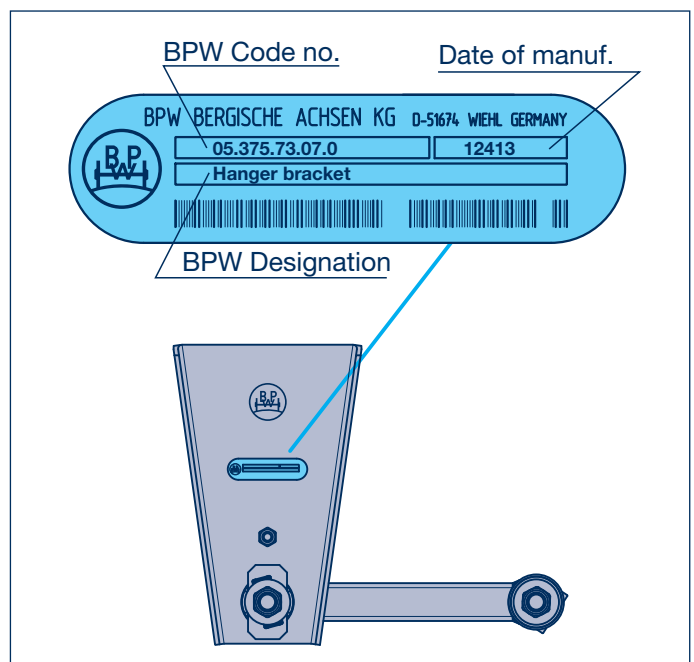

### Scope of delivery

When you order this BPW code number you receive the complete hanger bracket, including slider, connecting rod and attachment parts.

## 6 Front hanger brackets

### 6.2 Spare parts for front hanger brackets

#### 6.2.1 Weld-in bushes

##### Weld-in bushes for connecting rod attachment

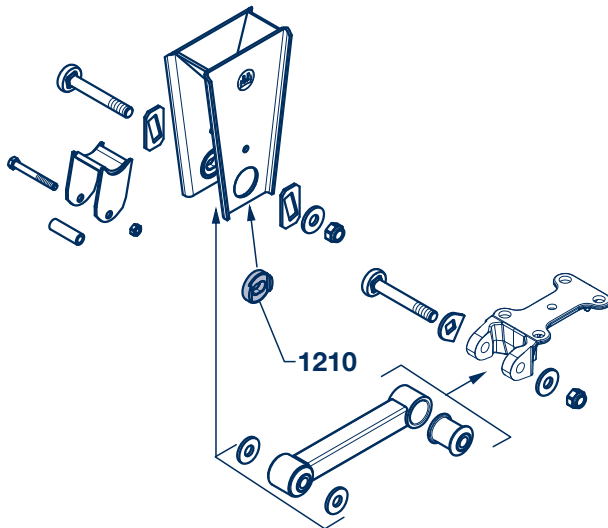
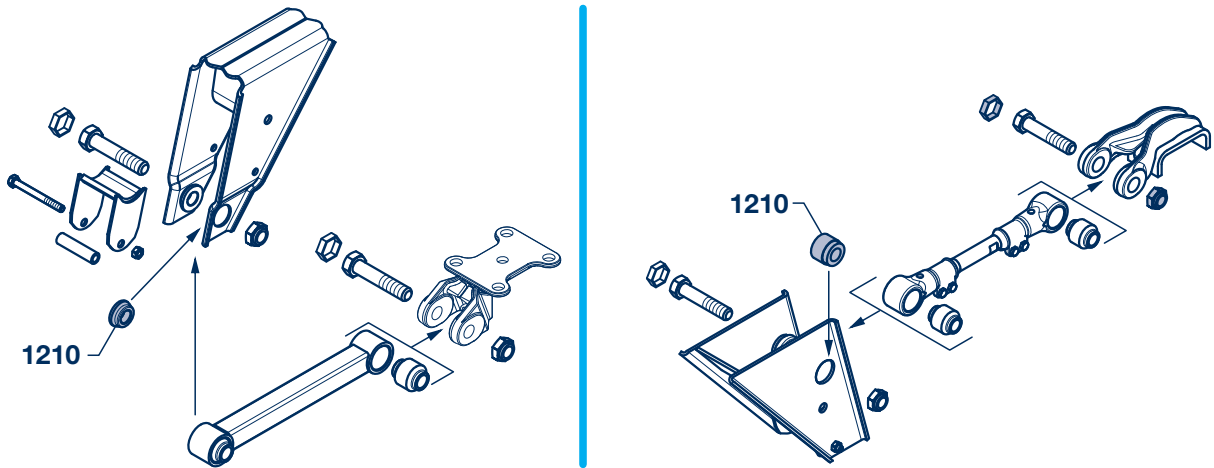

##### Weld-in bushes for drawbar attachment

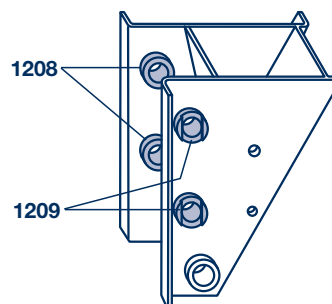
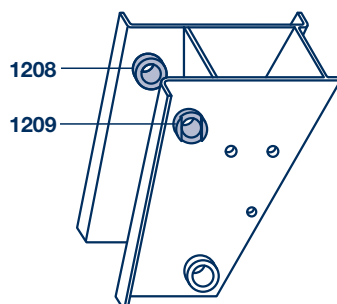

# Front hanger brackets **6**

## Spare parts for front hanger brackets **6.2**

### Weld-in bushes **6.2.1**

#### Weld-in bushes for connecting rod attachment

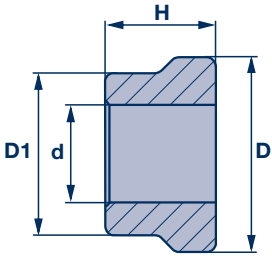
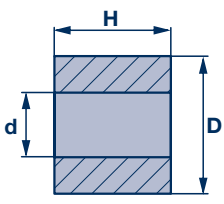
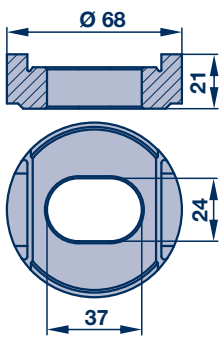
	Series	Item	Designation	Dimension				BPW Code no.	Qty. / Hanger bracket
				d	D1	D	H		
	<b>VB-K</b> <b>VB-KN</b> <b>VB-KE</b> <b>VBT-K</b> <b>VBT-KE</b> <b>VB-L</b> <b>VB-LE</b> <b>VB-M</b> <b>VB-ME</b> <b>VBT-M</b>	1210	Bush	30	50	60	21	03.113.01.19.0	2
	<b>VB-C</b> <b>VBT-C</b>	1210	Bush	30	50	60	30	03.200.34.05.0	2
					30	50	60	35	03.200.34.04.0 <sup>1)</sup>
	<b>VB</b> <b>VB-M</b>	1210	Bush	30	-	60	30	03.113.01.22.0	2
	<b>VB</b> <b>VBT</b> <b>VB-B</b> <b>VBT-B</b> <b>VB-E</b> <b>VBT-E</b> <b>VB-HD</b> <b>VB-HDE</b>	1210	Bush	36	-	65	40	03.200.75.01.0	2
	<b>VB ECO Cargo</b>	1210	Bush	24/37	-	68	21	03.113.03.10.0	2

#### Weld-in bushes for drawbar attachment

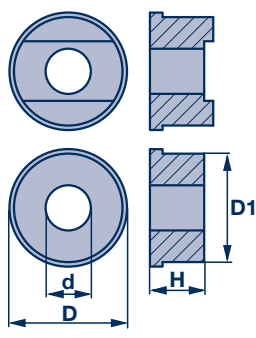
	<b>Ø 25</b>	1208	Bush without slot	25	58	65	30	03.113.00.19.0	1	
		1209	Bush with slot	25	58	65	35	03.113.00.18.0	1	
	<b>Ø 32</b>	1208	Bush without slot	32	58	65	30	03.113.02.05.0 <sup>1)</sup>	1	
		1209	Bush with slot	32	58	65	35	03.113.02.04.0	1	

<sup>1)</sup> no longer available

# 6 Front hanger brackets

## 6.2 Spare parts for front hanger brackets

### 6.2.2 Supports, sliders and attachment parts

**Supports, sliders and attachment parts**

**Fig. A**

1235  
1230  
1245  
1238  
M 14 M = 140 Nm

1410  
1410  
1412  
1415

I  
II  
III

**Fig. B**

1235  
1230  
1410  
1245  
1238  
M 14 M = 140 Nm

**Fig. C**

1235  
1230  
1245  
1238  
M 14 M = 140 Nm

**Fig. D**

1235  
1240  
1230  
1232  
1410  
1245  
1244  
M 20 M = 320 Nm  
1238  
M 14 M = 140 Nm

**Fig. E**

1240  
1235  
1232  
1230  
1410  
1245  
1244  
M 20 M = 320 Nm  
1238  
M 14 M = 140 Nm

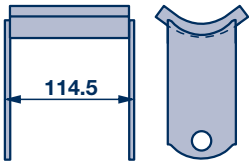
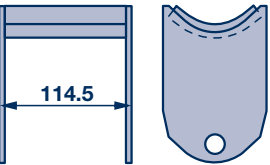
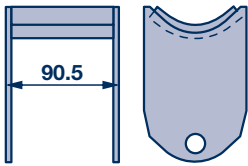
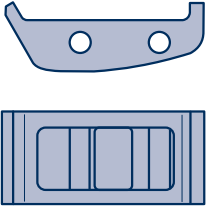
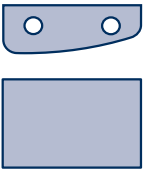

**Fig. F**

1235  
1232  
1230  
1245  
1238  
M 14 M = 140 Nm

# Front hanger brackets 6

## Spare parts for front hanger brackets 6.2

### Supports, sliders and attachment parts 6.2.2

Supports, sliders and attachment parts						
	Series	Item	Designation	Dimension	BPW Code no.	
<b>Fig. A</b> 	<b>VB-K</b> <b>VB-KN</b> <b>VB-KE</b> <b>VBT-K</b> <b>VBT-KE</b>	1230	Support ( normal I )		05.189.04.70.0	
			Support ( reinforced II )		05.189.05.22.0 <sup>1)</sup>	
			Support ( solid III )		05.189.05.97.0	
		1235	Hexagon screw	M 14 x 140 / 931-8.8	02.5022.09.80	
		1238	Lock nut	M 14-8	02.5273.14.82	
		1245	Tube	Ø 16 / 25 x 103	03.300.73.12.0	
<b>Fig. B</b> 	<b>VB-L</b> <b>VB-LE</b> <b>VBT-L</b> <b>VBT-LE</b> <b>VB-M</b> <b>VB-ME</b> <b>VBT-M</b>	1230	Support		05.189.05.75.0	
			Hexagon screw	M 14 x 140 / 931-8.8	02.5022.09.80	
			Lock nut	M 14-8	02.5273.14.82	
			Tube	Ø 16 / 25 x 103	03.300.73.12.0	
<b>Fig. C</b> 	<b>VB ECO Cargo</b>	1230	Support		05.189.16.07.0	
			Hexagon screw	M 14 x 120	02.5022.12.80	
			Lock nut	M 14-8	02.5273.14.82	
			Tube	Ø 16 / 25 x 79	03.300.73.42.0	
<b>Fig. D</b> 	<b>VB</b> <b>VB-B</b> <b>VB-E</b> <b>VB-HD</b> <b>VB-HDE</b>	1230	Block		03.221.89.05.0	
			1232	Plate		03.285.45.08.0
			1235	Hexagon screw	M 14 x 150 / 931-8.8	02.5022.10.80
			1238	Lock nut	M 14-8	02.5273.14.82
			1240	Hexagon screw	M 20 x 160 / 931-8.8	02.5023.09.82
			1244	Lock nut	VM 20 / 980-8	02.5220.50.82
			1245	Tube	Ø 14.8 / 20 x 103	03.300.72.05.0
<b>Fig. E</b> 	<b>VBT</b> <b>VBT-B</b> <b>VBT-E</b>	1230	Block		03.221.79.01.0	
			1232	Plate		03.285.45.08.0
			1235	Hexagon screw	M 14 x 150 / 931-8.8	02.5022.10.80
			1238	Lock nut	M 14-8	02.5273.14.82
			1240	Hexagon screw	M 20 x 160 / 931-8.8	02.5023.09.82
			1244	Lock nut	VM 20 / 980-8	02.5220.50.82
			1245	Tube	Ø 14.8 / 20 x 103	03.300.72.05.0
<b>Fig. F</b> 	<b>VB-C</b> <b>VBT-C</b>	1230	Slider		03.181.40.11.0	
			1232	Plate		03.285.36.01.0
			1235	Hexagon screw	M 14 x 140 / 931-8.8	02.5022.09.80
			1238	Lock nut	M 14-8	02.5273.14.82
			1245	Tube	Ø 16 / 25 x 106	03.300.73.21.0
<b>Silent block bushes</b>						
		1410	Rubber roll	Ø 20 / 40 x 80	02.1205.02.00	
			Bush	Ø 20 / 80 x 80	03.113.90.11.0	
				Ø 25 / 80 x 80	03.113.90.05.0	
		1412	Bush	Ø 40 / 80 x 80	03.113.94.04.0	
		1415	Slider		03.181.90.10.0 <sup>1)</sup>	

<sup>1)</sup> no longer available

# 7 Equalizing beams

## 7.1 General

### Mode of operation

In the case of multi-axle suspension units, the middle connecting pieces have pivoting equalising beams. The spring ends slide-mounted in the equalising beams together achieve static axle equalisation (even distribution of axle load when stationary and on the move).

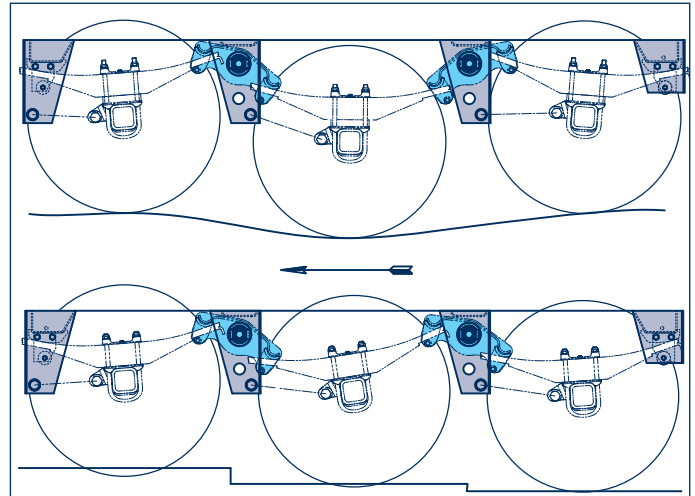

### Equalizing beam bearing

Maintenance-free **rubber-steel bushes** are used in the weight range from 9 to 14 tonnes axle load.

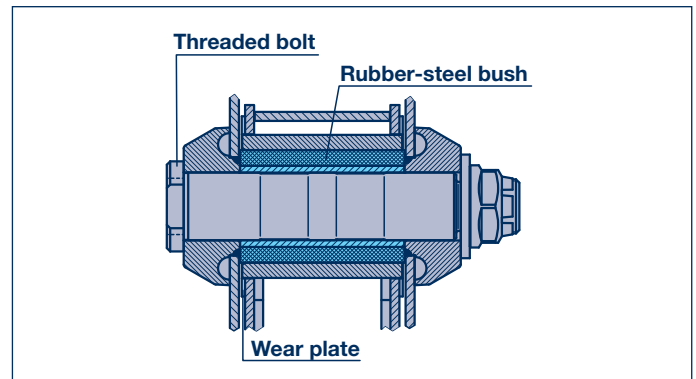

High-quality, durable **bronze bushes** are used for heavy axle loads (9 - 20 tonnes) as well as for extreme off-road applications.

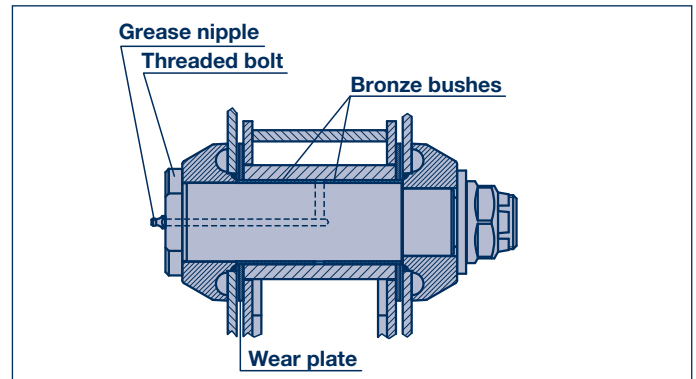

### Anti-rotation device for threaded bolts

The threaded bolt is secured against twisting by means of a welded-on ring or welded-on lugs.

In **VB ECO Cargo** a folded disc (profiled sheet) is welded to the hanger bracket under the threaded bolt head.

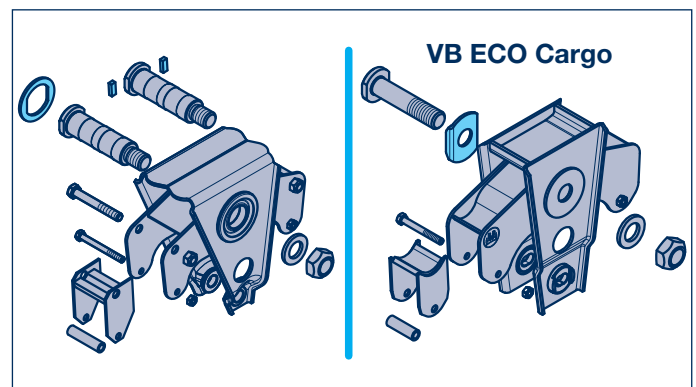

# Equalizing beams 7

## General 7.1

### Sliders

The ends of the leaf springs are slidemounted in the equalising beams by means of screwed-in sliders or welded-in retainers made of hardened steel alloy.

In this context it should be ensured that the sliding points are always well greased.

Note the position of the retainers when replacing them (see illustration on the right and chapter 7.2.5).

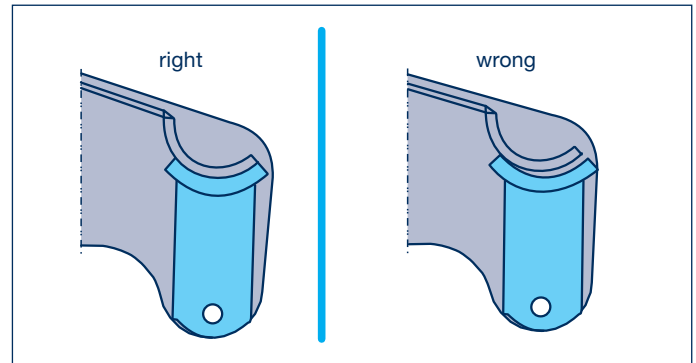

### BPW Code number

The BPW code number is stamped into the manufacturer's nameplate on the connecting piece for the equalising beam.

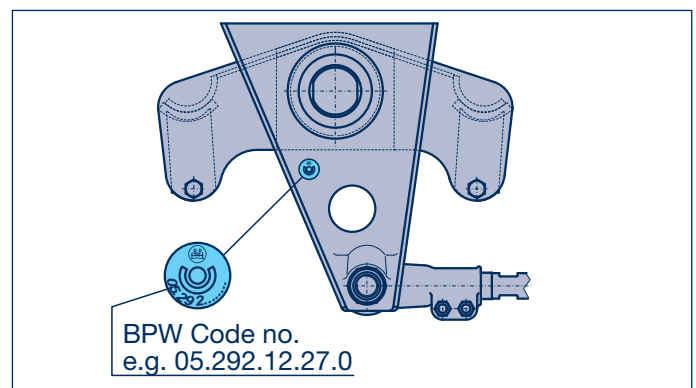

**VB ECO Cargo** equalizing beams with integrated wheel alignment are provided with a type plate on each hanger bracket. It shows the name, BPW code number and the date of manufacture.

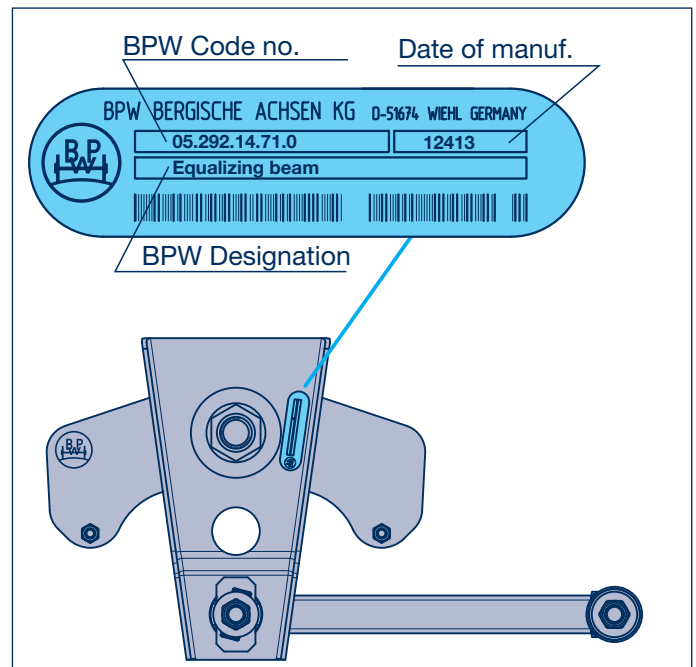

### Scope of delivery

When you order this BPW code number you get the complete equalising beam, including connecting piece, sliders, connecting rod and attachment parts.

# 7 Equalizing beams

## 7.2 Spare parts for equalizing beams

### 7.2.1 Equalizing beams

#### Equalizing beams

#### Straight equalizing beam

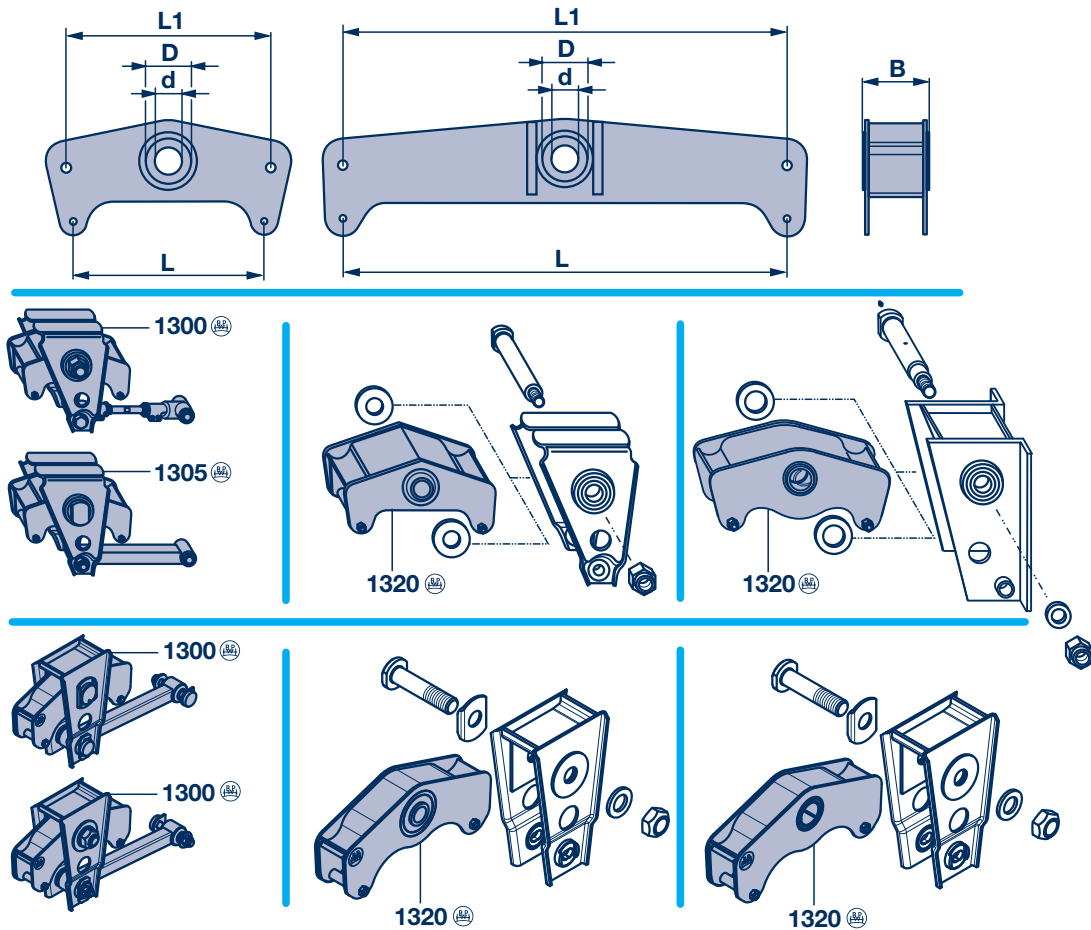

#### Equalizing beam with offset (for steering axles)

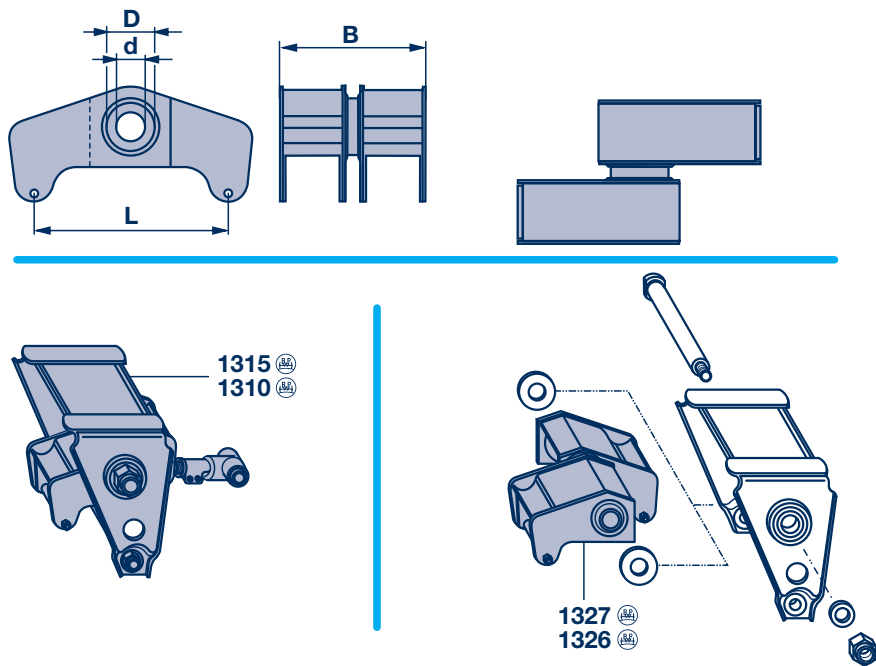



# Equalizing beams 7

## Spare parts for equalizing beams 7.2

### Equalizing beams 7.2.1

#### Equalizing beams

Item	Designation	Utilisation	BPW Code no.
1300	Equalizing beam assembly cpl., straight, right	VB	see type plate
1300	Equalizing beam assembly cpl., straight, right + left	VB ECO Cargo	
1310	Equalizing beam assembly cpl., with offset, right	for steering axles	
1305	Equalizing beam assembly cpl., straight, left	VB	
1315	Equalizing beam assembly cpl., with offset, left	for steering axles	

#### Straight equalizing beam (item 1320)

Series	Wheel base	Axle load	Dimension					BPW Code no.	● = with bush inserted	● = with support fitted (slider)	● = with welded wear plate
			L	L1	B	D	d				
<b>Equalizing beam bearing with rubber-steel bushes</b>											
<b>VB</b> <b>VB-B</b> <b>VB-L</b>	1360, 1410, 1500	10 - 16 t	420	450	142	100	60	09.291.00.08.1 <sup>1)</sup>	●		
<b>VB</b> <b>VB-B</b> <b>VB-L</b>	2050	10 - 12 t	1000	1000	142	100	60	09.291.00.39.0 <sup>1)</sup>	●		
<b>VB-K</b>	1140, 1360	6.5 - 10 t	385	-	128	94	50	05.291.11.13.0 05.291.11.77.0	●	●	
<b>VB-M</b>	1140, 1310, 1360	8 - 12 t	385	400	128	100	60	05.291.11.50.0	●		
<b>VB-M</b>	1820	8 - 12 t	850	860	128	100	60	05.291.12.38.0	●		
<b>VB-HD</b>	1360, 1410, 1500	14 - 20 t	416	-	142	100	60	05.291.01.11.0		●	●
<b>VB M ECO Cargo</b> <b>VBN M ECO Cargo</b>	1310, 1360	8 - 12 t	385	-	104	100	42	05.291.12.96.0	●	●	
	1380	8 - 12 t	455	-				05.291.13.04.0	●	●	
	1600	8 - 12 t	625	640				05.291.13.00.0	●	●	
	1820	8 - 12 t	850	860				05.291.13.02.0	●	●	
<b>Equalizing beam bearing with bronze bushes</b>											
<b>VB-B</b> <b>VB-BE</b>	1360, 1410, 1500	13 - 16 t	420	450	136	75	70	05.291.00.84.0	●		
<b>VB-ME</b>	1140, 1310, 1360	8 - 12 t	385	400	128	65	60	05.291.11.70.0	●		
<b>VB-ME</b>	1820	8 - 12 t	850	860	128	65	60	05.291.12.90.0	●		
<b>VB-HDE</b>	1360, 1410, 1500	14 - 20 t	416	-	136	75	70	05.291.01.14.0	●	●	
<b>VB ME ECO Cargo</b>	1360	8 - 12 t	385	-	104	65	60	05.291.12.98.0	●	●	

#### Equalizing beam with offset (item 1326 / 1327)

<b>Equalizing beam bearing with rubber-steel bushes</b>											
<b>VB-K</b> <b>Offset 122 *</b>	1360	6.5 - 10 t	385	-	258	94	50	05.291.11.26.0 R 05.291.11.25.0 L	●	●	
<b>VB-K</b> <b>Offset 160 *</b>	1360	6.5 - 10 t	385	-	258	94	50	05.291.11.20.0 R 05.291.11.19.0 L	●	●	

Further types upon request.

\* see page 54

<sup>1)</sup> no longer available

# 7 Equalizing beams

## 7.2 Spare parts for equalizing beams

### 7.2.2 Weld-in bushes

#### Weld-in bushes for connecting rod attachment

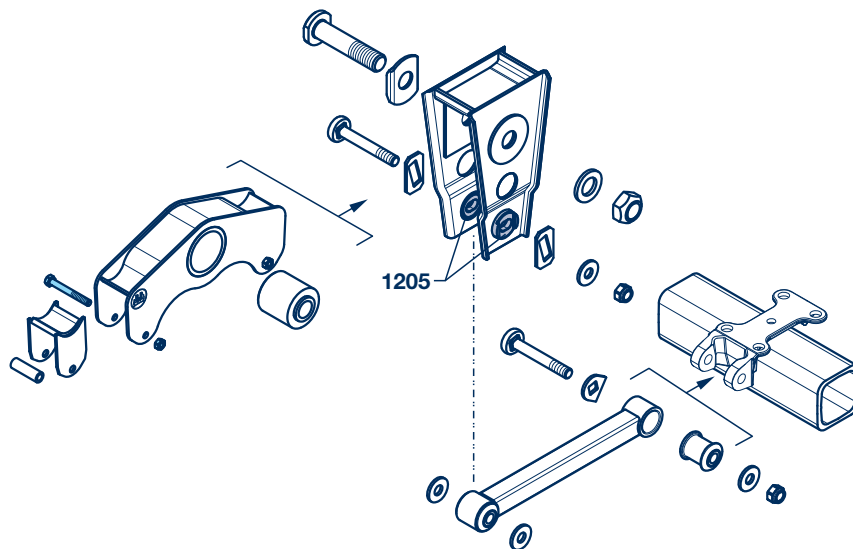
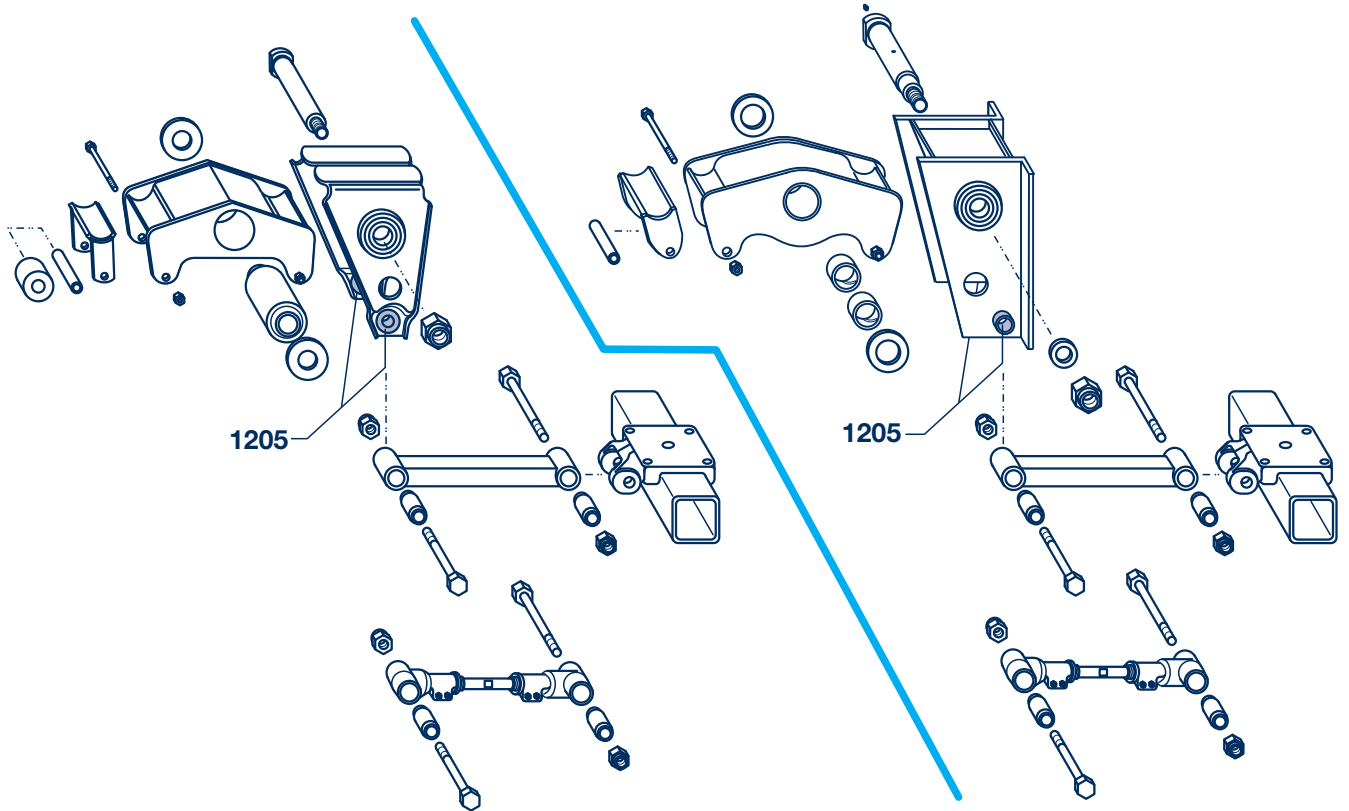



# 7 Equalizing beams

## 7.2 Spare parts for equalizing beams

### 7.2.2 Weld-in bushes

#### Weld-in bushes for equalizing beam bearing

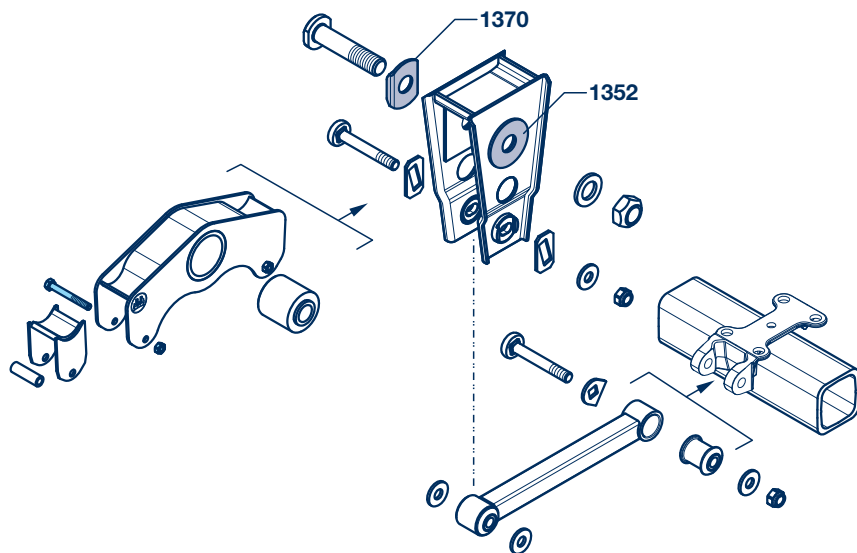
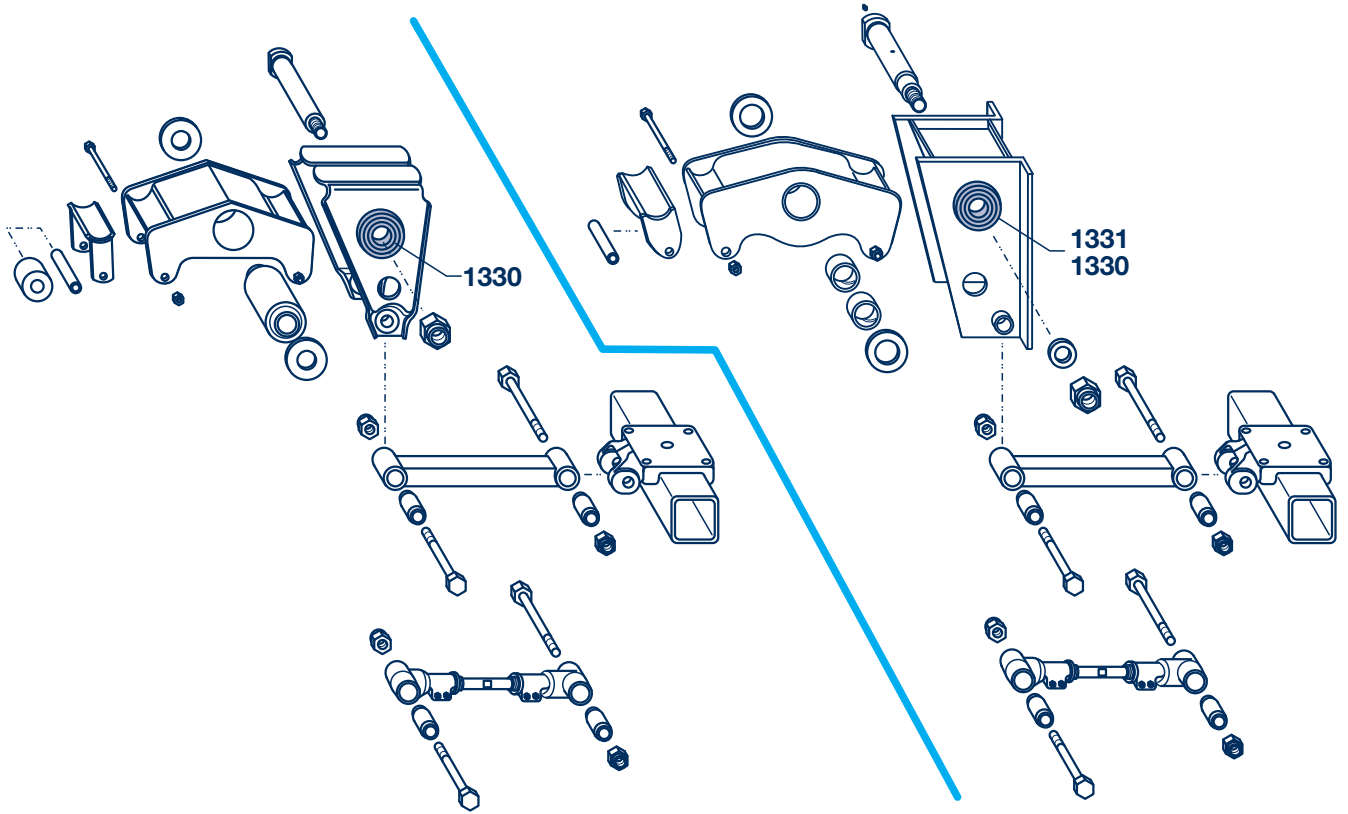

# Equalizing beams 7

## Spare parts for equalizing beams 7.2

### Weld-in bushes 7.2.2

#### Weld-in bushes for equalizing beam bearing

	Series	Item	Designation	Fig.	Dimension				BPW Code no.	Qty. / Hanger bracket
					d	D1	D	H		
	<b>Equalizing beam bearing with rubber-steel bushes</b>									
	VB-K	1330	Bush	a	50	114	130	28	03.113.06.10.0	2
	VB			b	60	87	140	35	03.113.07.03.0	2
	VB-B									
	VB-L									
	VB-M			a	60	114	130	28	03.113.06.11.0 <sup>1)</sup>	2
	VB-HD			b	60	87	140	50	03.113.07.14.0	2
	VB-C			b	50	74	130	32	03.113.06.06.0 <sup>1)</sup>	2
	VB M ECO Cargo	1352	Washer	c	Ø 42 / 119 x 6				03.320.16.10.0	1
	VB N M ECO Cargo	1370	Shaped plate	d					03.161.44.10.0	1
	<b>Equalizing beam bearing with bronze bushes</b>									
	VB-KE	1330	Bush	a	50	114	130	28	03.113.06.10.0	1
	VB-ME	1331	Bush	a	60	114	130	28	03.113.06.11.0 <sup>1)</sup>	1
	VB-E			b	60	87	140	33	03.113.07.12.0	1
	VB-BE									
VB-LE										
VB-HDE			b	60	87	140	49	03.113.07.16.0	1	
			b	70	87	140	49	03.113.07.15.0	1	
VB ME ECO Cargo	1352	Washer	c	Ø 42 / 119 x 6				03.320.16.10.0	1	
	1370	Shaped plate	d					03.161.44.10.0	1	

<sup>1)</sup> no longer available

# 7 Equalizing beams

## 7.2 Spare parts for equalizing beams

### 7.2.3 Equalizing beam bearing - Bushes, wear plates

Bushes	
Equalizing beam bearing with rubber-steel bushes	
Straight equalizing beam	VB M ECO Cargo / VBN M ECO Cargo
Equalizing beam with offset (with steering axles)	
Equalizing beam bearing with bronze bushes	
Straight equalizing beam	VB ME ECO Cargo

# Equalizing beams 7

## Spare parts for equalizing beams 7.2

### Equalizing beam bearing - Bushes, wear plates 7.2.3

#### Bushes

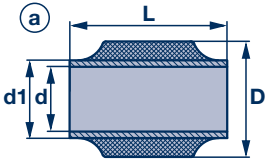
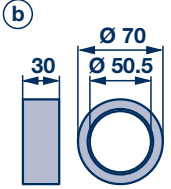
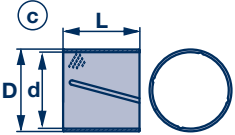
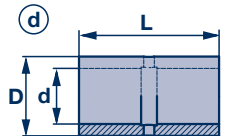
	Series	Item	Designation	Fig.	Dimension				BPW Code no.	Qty. / Equalizing beam	
					d	D1	D	L			
<b>Equalizing beam bearing with rubber-steel bushes</b>											
<b>Straight equalizing beam</b>											
	VB-K VB-C	1340	Bush	a	50	58	100	130	02.0316.65.00	1	
	VB-M			a	60	72	107	130	05.113.97.13.0	1	
	VB VB-B VB-HD VB-L			a	60	72	107	150	05.113.97.10.0	1	
	VB M ECO Cargo VBN M ECO Cargo			b	42	60	106	106	05.113.97.26.0	1	
	<b>Equalizing beam with offset (with steering axles)</b>										
	VB-K VB-C	1340	Bush	a	50	58	100	130	02.0316.65.00	2	
		1341	Ring *	b	Ø 50.5 / 70 x 30				03.310.34.27.0	1	
	VB VB-B VB-HD VB-L	1340	Bush	a	60	72	107	150	05.113.97.10.0	2	
* only with offset 160 mm (no longer available)											
<b>Equalizing beam bearing with bronze bushes</b>											
	VB-KE VB-ME	1340	Bush	c	60	-	65	60	03.112.76.14.0	2	
	VB-E VB-BE VB-HDE VB-LE			c	70	-	75	70	03.112.76.13.0	2	
	VB ME ECO Cargo	1340	Bush	c	60	-	65	50	03.112.76.27.0	2	
		1342	Sleeve	d	42	-	60	106	03.200.17.05.0	1	
<b>Wear plates</b>											
		1350	Washer	Ø 50 / 115 x 6				03.320.36.12.0	2		
			Ring	Ø 60 / 115 x 6				03.310.36.50.0	2		
				Ø 76 / 140 x 4				03.310.37.31.0	2		
				Plate	176 x 160 / Ø 128 x 3				03.285.25.35.0	2	
VB M ECO Cargo VBN M ECO Cargo VB ME ECO Cargo		1350	Plate	Ø 43 / 150 x 150 x 6				03.281.45.19.0	2		

# 7 Equalizing beams

## 5.2 Spare parts for equalizing beams

### 7.2.4 Equalizing beam bearing - Threaded bolts

Threaded bolts	
Equalizing beam bearing with rubber-steel bushes	
<p><b>Straight equalizing beam</b></p> <p>M 42 x 3 M = 1100 Nm -12t  M 42 x 3 M = 1700 Nm 13t-  M 48 x 3 M = 1250 Nm</p>	<p><b>VB M ECO Cargo / VBN M ECO Cargo</b></p> <p>M 42 x 3 M = 1300 Nm</p>
<p><b>Equalizing beam with offset (with steering axles)</b></p> <p>M 42 x 3 M = 1100 Nm -12t  M 42 x 3 M = 1700 Nm 13t-  M 48 x 3 M = 1250 Nm</p>	
Equalizing beam bearing with bronze bushes	
<p><b>Straight equalizing beam</b></p> <p>M 42 x 3 M = 1100 Nm -12t  M 42 x 3 M = 1700 Nm 13t-  M 48 x 3 M = 1250 Nm</p>	<p><b>VB ME ECO Cargo</b></p> <p>M 42 x 3 M = 1300 Nm</p>



# Equalizing beams 7

## Spare parts for equalizing beams 7.2

### Equalizing beam bearing - Threaded bolts 7.2.4

Threaded bolts									
	Item	Designation	Fig.	Dimension					BPW Code no.
				d	D	L	SW	Thread	
	<b>Equalizing beam bearing with rubber-steel bushes</b>								
	<b>Straight equalizing beam</b>								
	1345	Threaded bolt	a	-	42	207	70	M 42 x 3	03.177.16.40.0 <sup>1)</sup>
			b	-	50	247	60		03.177.16.25.0
			b	-	60	257	70		03.177.16.29.0
			b	-		265		03.177.16.35.0 *	
			b	-		285		03.177.16.20.0	
			b	-	313	M 48 x 3	03.177.17.05.0		
	* Locking with castle nut and split pin								
	<b>Equalizing beam with offset (with steering axles)</b>								
	1346	Threaded bolt	b	-	50	377	60	M 42 x 3	03.177.16.26.0
			b	-		404			03.177.16.27.0
b			-	60	459	70	M 48 x 3	03.177.17.06.0	
	<b>Equalizing beam bearing with bronze bushes</b>								
	<b>Straight equalizing beam</b>								
	1345	Threaded bolt	c	-	42	207	70	M 42 x 3	03.177.16.41.0 <sup>1)</sup>
			d	50	60	245			03.177.16.28.0
			d	60	70	274			03.177.16.30.0
			d	60	70	381	80	M 48 x 3	03.177.16.17.0
	1347	Grease nipple	AM 10 x 1 / 71412						03.177.17.04.0
1347	Grease nipple	AM 10 x 1 / 71412						02.6802.03.50 <sup>1)</sup>	
	1353	Washer	43 / 125					02.5401.43.01 <sup>1)</sup>	
						A 50 / 125		02.5401.50.09	
	<b>Threaded bolt with lock nut</b>								
	1360	Lock nut	VM 42 x 3 / 980-06					02.5220.91.26 <sup>1)</sup>	
			VM 42 x 3 / 980-8					02.5220.90.82	
			M 48 x 3					02.5273.39.00	
<b>Threaded bolt with castle nut</b>									
1360	Castle nut	M 42 x 3 / 937-04					02.5207.46.04		
1361	Split pin	8 x 63 / 94					02.6201.84.01		
	<b>Torsion protection for threaded bolts</b>								
	1370	Ring *	SW 60					03.310.76.10.0	
			SW 70					03.310.76.11.0	
1370	Shaped plate	SW 70					03.161.44.10.0 <sup>1)</sup>		
* It is possible to prevent the bolt rotating by using weld-on lugs.									

<sup>1)</sup> VB ECO Cargo

# 7 Equalizing beams

## 7.2 Spare parts for equalizing beams

### 7.2.5 Supports, sliders and attachment parts

#### Supports, sliders and attachment parts

Fig. A

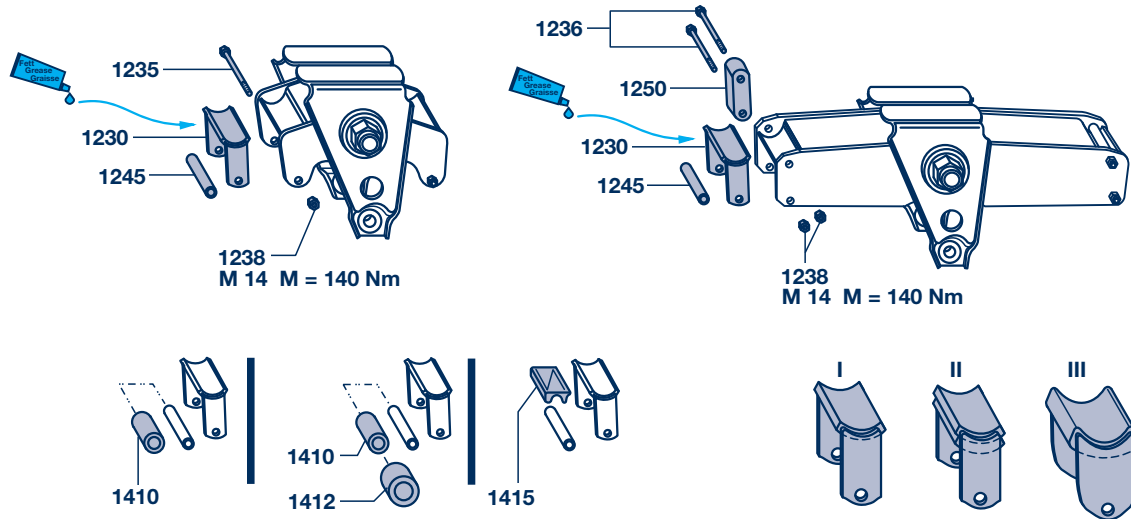

Fig. B

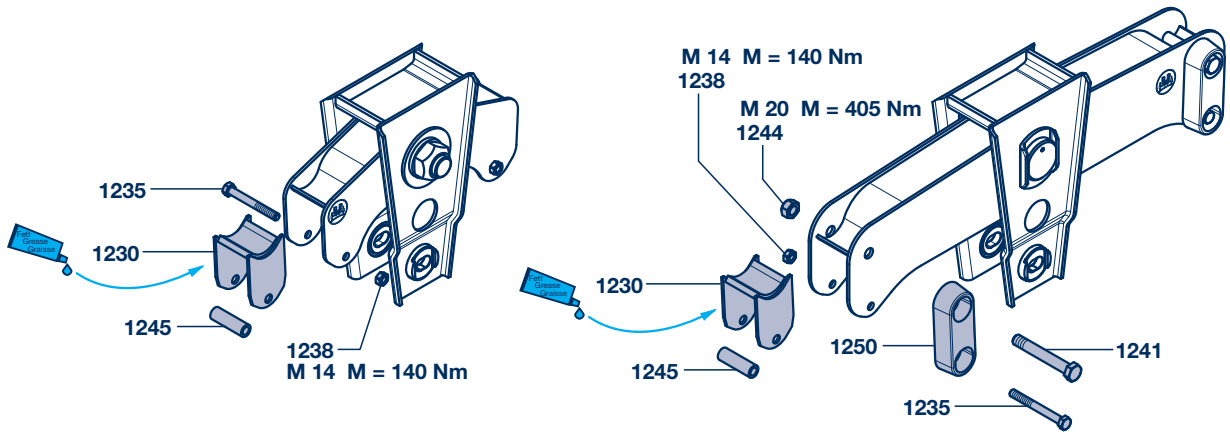
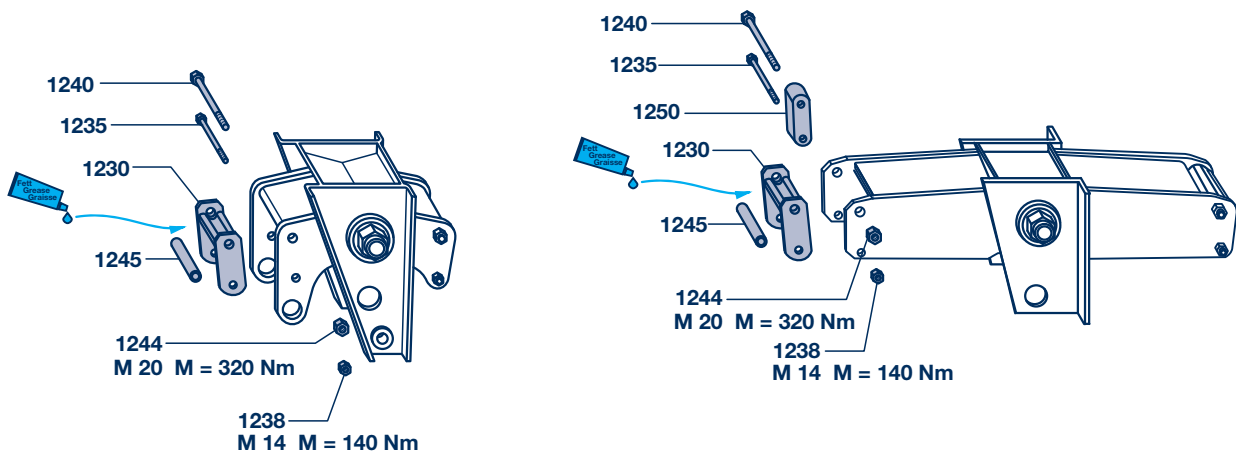

Fig. C



# Equalizing beams 7

## Spare parts for equalizing beams 7.2

### Supports, sliders and attachment parts 7.2.5

#### Supports, sliders and attachment parts

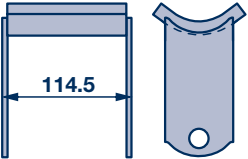
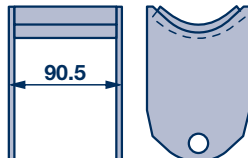
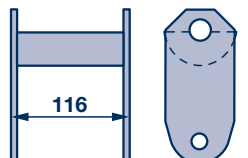
	Series	Item	Designation	Dimension	BPW Code no.
<b>Fig. A</b> 	<b>VB-K</b> <b>VB-KN</b> <b>VB-KE</b> <b>VBT-K</b> <b>VBT-KE</b>	1230	Support ( normal I )		05.189.04.70.0
			Support ( reinforced II )		05.189.05.22.0 <sup>1)</sup>
			Support ( solid III )		05.189.05.97.0
		1235	Hexagon screw	M 14 x 140 / 931-8.8	02.5022.09.80
		1236	Screw (with shackle item 1250)	M 14 x 150 / 931-8.8	02.5022.10.80
		1238	Lock nut	M 14-8	02.5273.14.82
		1245	Tube	Ø 14.8 / 20 x 103	03.300.72.05.0
		1250	Shackle (for WB 1820 / 2050)	120 / 2 x Ø 15	03.232.96.03.0
<b>Fig. B</b> 	<b>VB M ECO Cargo</b> <b>VBN M ECO Cargo</b> <b>VB ME ECO Cargo</b>	1230	Support		05.189.16.07.0
		1235	Hexagon screw	M 14 x 120	02.5022.12.80
		1236	Hexagon screw (with shackle item 1250)	M 14 x 130 / 931-8.8	02.5022.11.82
		1238	Lock nut	M 14-8	02.5273.14.82
		1241	Screw (with shackle item 1250)	M 20 x 140 / 931-8.8	02.5023.19.80
		1244	Lock nut	VM 20 / 980-8	02.5220.50.82
		1245	Tube	Ø 16 / 25 x 79	03.300.73.42.0
		1250	Shackle (for WB 1820 / 2050)	120 / 1 x Ø 15 / 1 x Ø 21	03.232.96.02.0 <sup>1)</sup>
<b>Fig. C</b> 	<b>VB-C</b> <b>VBT-C</b>	1230	Support		05.189.02.87.0
		1235	Hexagon screw	M 14 x 140 / 931-8.8	02.5022.09.80
		1236	Hexagon screw (with shackle item 1250)	M 14 x 150 / 931-8.8	02.5022.10.80
		1238	Lock nut	M 14-8	02.5273.14.82
		1240	Screw	M 20 x 150	03.340.13.07.0
		1241	Screw (with shackle item 1250)	M 20 x 160	03.340.13.05.0
		1244	Lock nut	VM 20 / 980-8	02.5220.50.82
		1245	Tube	Ø 16 / 25 x 106	03.300.73.21.0
				1250	Shackle (for WB 1820 / 2050)

<sup>1)</sup> no longer available

Silent block bushes see page 61.

# 7 Equalizing beams

## 7.2 Spare parts for equalizing beams

### 7.2.5 Support, sliders and attachment parts

#### Supports, sliders and attachment parts

Fig. D

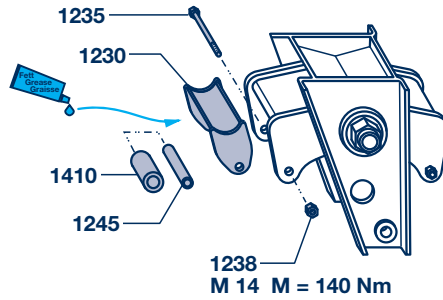

Fig. E

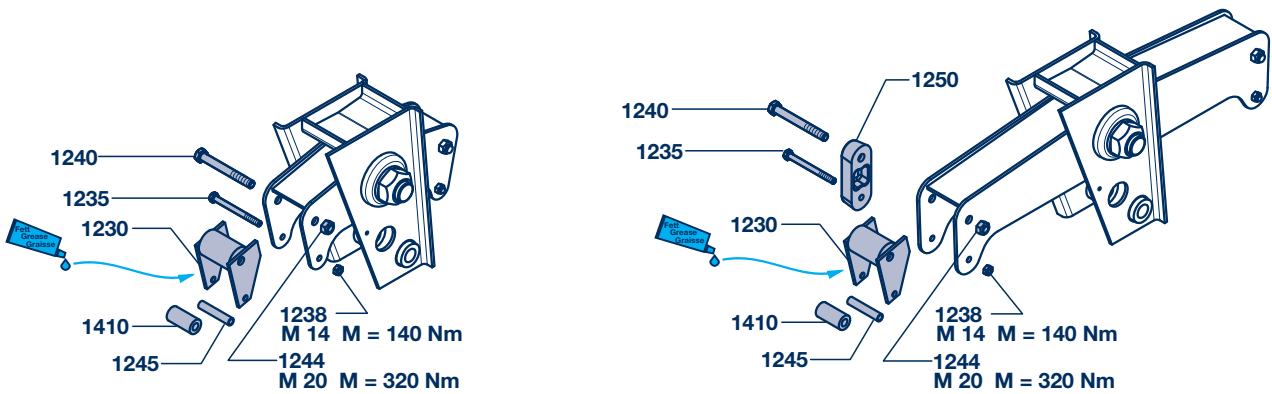
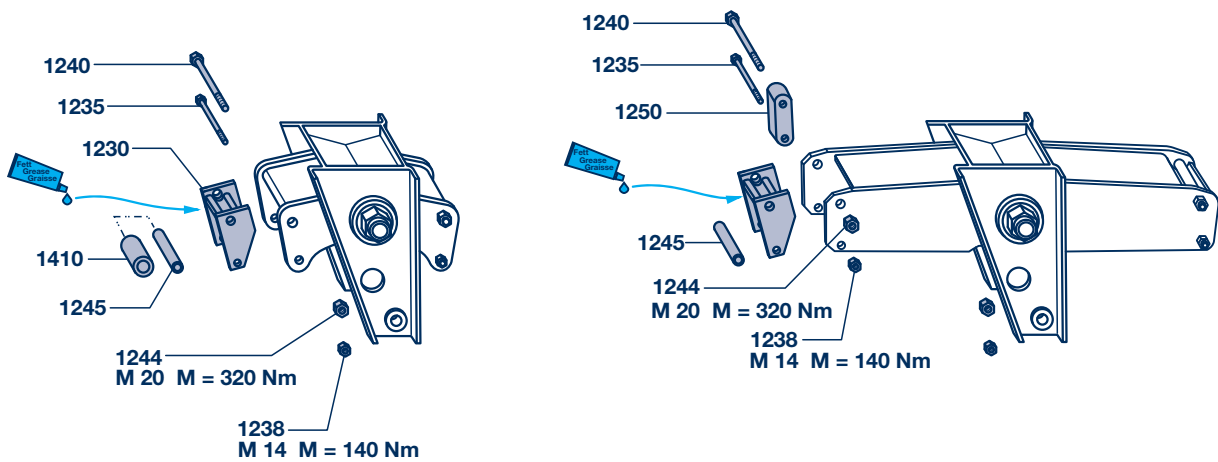

Fig. F



# Equalizing beams 7

## Spare parts for equalizing beams 7.2

### Supports, sliders and attachment parts 7.2.5

#### Supports, sliders and attachment parts

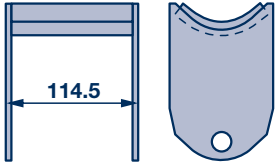
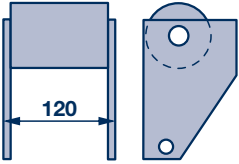
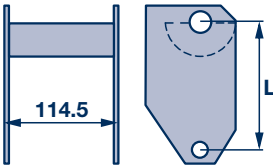
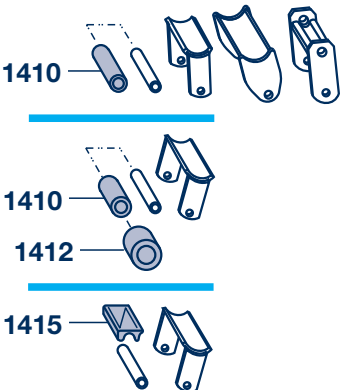
<b>Fig. D</b> 	<b>VB-HD</b> <b>VB-HDE</b>	1230	Support		05.189.14.52.0
		1235	Hexagon screw	M 14 x 150 / 931-8.8	02.5022.10.80
		1238	Lock nut	M 14-8	02.5273.14.82
		1245	Tube	Ø 14.8 / 20 x 103	03.300.72.05.0
<b>Fig. E</b> 	<b>VB</b> <b>VB-T</b> <b>VB-B</b> <b>VB-BE</b> <b>VB-E</b> <b>VB-T-E</b> <b>VB-L</b> <b>VB-LE</b> <b>VB-T-L</b> <b>VB-T-LE</b>	1230	Support		05.189.02.70.0
		1235	Hexagon screw	M 14 x 150 / 931-8.8	02.5022.10.80
		1236	Hexagon screw (with shackle item 1250)	M 14 x 160 / 931-8.8	02.5022.15.80 <sup>1)</sup>
		1238	Lock nut	M 14-8	02.5273.14.82
		1240	Screw	M 20 x 160	03.340.13.05.0
		1241	Screw (with shackle item 1250)	M 20 x 170	03.340.13.06.0 <sup>1)</sup>
		1244	Lock nut	VM 20 / 980-8	02.5220.50.82
		1245	Tube	Ø 14.8 / 20 x 103	03.300.72.05.0
		1250	Shackle (for WB 1820 / 2050)	120 / 1 x Ø 15 / 1 x Ø 21	03.232.96.02.0 <sup>1)</sup>
<b>Fig. F</b> 	<b>VB-M</b> <b>VB-ME</b> <b>VB-T-M</b> <b>VB-T-ME</b>	1230	Support (standard)	L = 128	05.189.05.82.0
			Support (for WB 1820/2050)	L = 120	05.189.05.90.0 <sup>1)</sup>
		1235	Hexagon screw	M 14 x 140 / 931-8.8	02.5022.09.80
			Hexagon screw (with shackle item 1250)	M 14 x 160 / 931-8.8	02.5022.15.80 <sup>1)</sup>
		1238	Lock nut	M 14-8	02.5273.14.82
		1240	Screw	M 20 x 150	03.340.13.07.0
		1241	Screw (with shackle item 1250)	M 20 x 170	03.340.13.06.0 <sup>1)</sup>
		1244	Lock nut	VM 20 / 980-8	02.5220.50.82
		1245	Tube	Ø 14.8 / 20 x 103	03.300.72.05.0
		1250	Shackle (for WB 1820 / 2050)	120 / 1 x Ø 15 / 1 x Ø 21	03.232.96.02.0 <sup>1)</sup>
<b>Silent block bushes</b>					
	1410	Rubber roll	Ø 20 / 40 x 80	02.1205.02.00	
		Bush	Ø 20 / 80 x 80	03.113.90.11.0	
			Ø 25 / 80 x 80	03.113.90.05.0	
	1412	Bush	Ø 40 / 80 x 80	03.113.94.04.0 *	
	1415	Slider		03.181.90.10.0 <sup>1)</sup>	
* Replaced by 03.113.90.11.0 (Item 1410)					

<sup>1)</sup> no longer available

## 8 Rear hanger brackets

### 8.1 General

#### VB

The rear hanger brackets welded onto the vehicle chassis are only connected to the final axle of the suspension unit by means of the leaf springs, and they only transfer the tracking forces of the axle to the chassis of the vehicle.

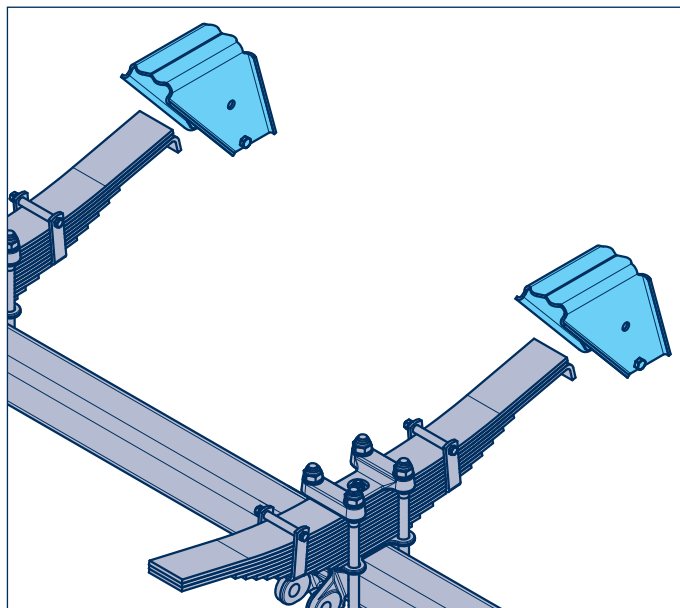

#### VBT

The rear hanger brackets welded onto the vehicle chassis are connected to the last axle of the suspension unit by means of connecting rods, and convey all the tracking, braking and acceleration forces from the axle into the vehicle chassis.

Adjustable connecting rods are fitted on one side (or both) to ensure easy tracking of the vehicle.

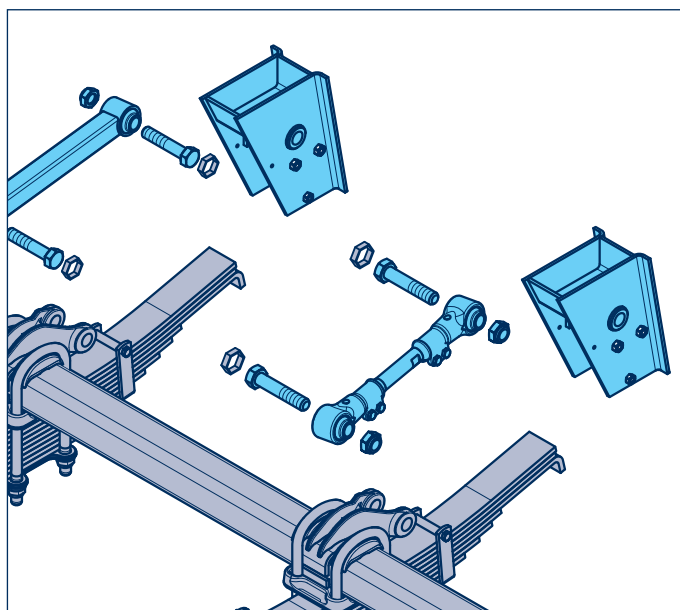

#### Sliders

The ends of the leaf spring are slide-mounted in the connecting pieces by means of screwed-in sliders or welded-in retainers made of hardened steel alloy.

In this context it should be ensured that the sliding points are always well greased.

Thick-walled lateral wear plates ensure precise guidance of the spring ends in the connecting pieces.

Note the correct position of the retainers when replacing them!

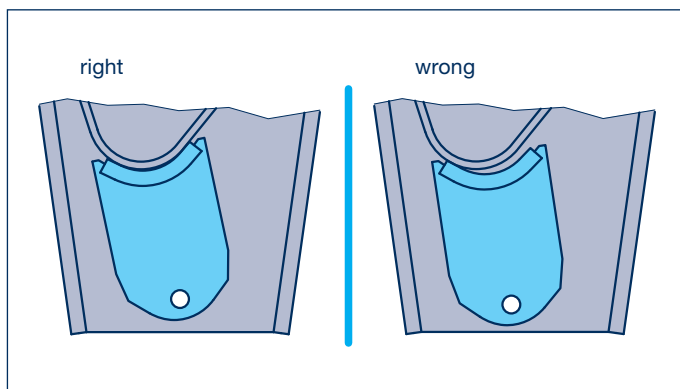

# Rear hanger brackets 8

## General 8.1

### BPW Code number

The BPW code number is stamped into the manufacturer's nameplate on the hanger bracket.

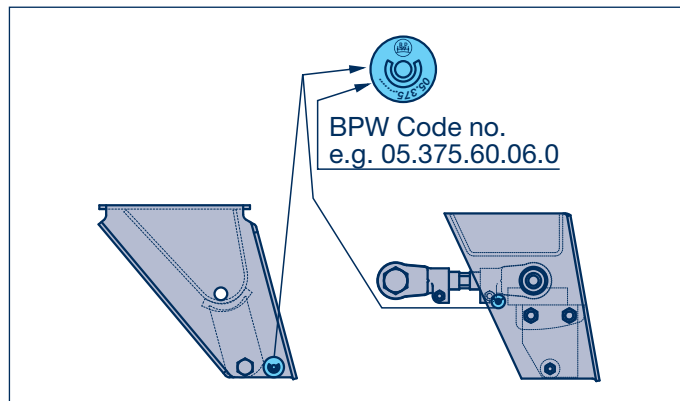

**VB ECO Cargo** hanger brackets are provided with a type plate on each bracket. It shows the name, BPW code number and the date of manufacture.

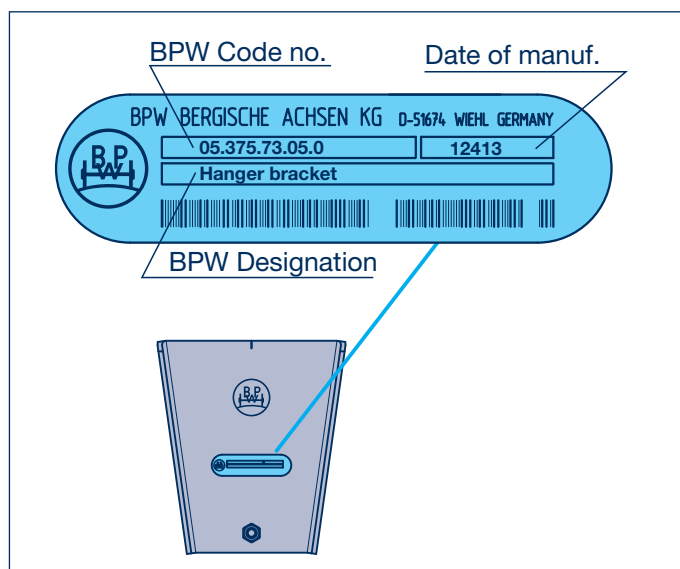

### Scope of delivery

When you order this BPW code number you get the complete hanger bracket, including slider, connecting rod (if available) and attachment parts.

# 8 Rear hanger brackets

## 8.2 Spare parts for rear hanger brackets

### 8.2.1 Weld-in bushes

#### Weld-in bushes for connecting rod attachment (only VBT)

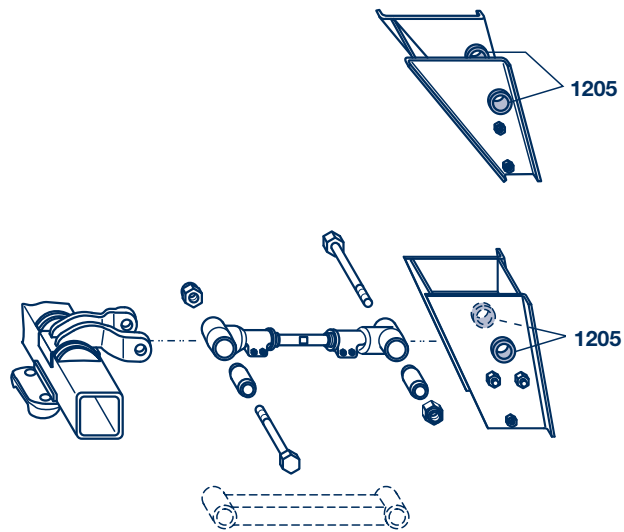
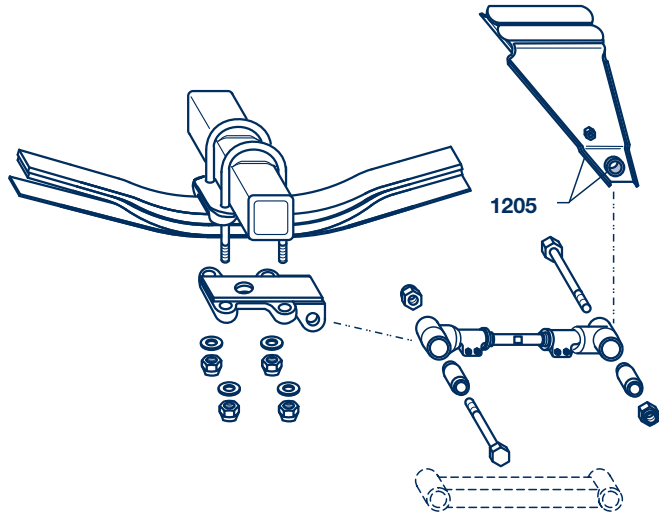



# Rear hanger brackets 8

## Spare parts for rear hanger brackets 8.2

### Weld-in bushes 8.2.1

#### Weld-in bushes for connecting rod attachment (only VBT)

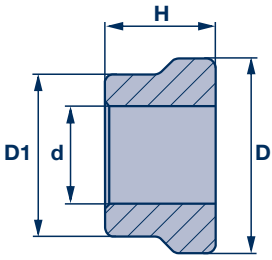
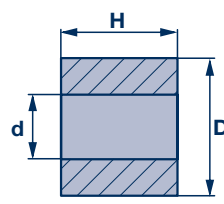
	Series	Item	Designation	Dimension				BPW Code no.	Qty. / Hanger bracket
				d	D1	D	H		
	<b>VBT-K</b> <b>VBT-KE</b> <b>VBT-L</b> <b>VBT-LE</b> <b>VBT-M</b> <b>VBT-ME</b>	1210	Bush	30	50	60	21	03.113.01.19.0	2
	<b>VBT-C</b>	1210	Sleeve	30	50	60	30	03.200.34.05.0	2
					30	50	60	35	03.200.34.04.0 <sup>1)</sup>
	<b>VBT</b> <b>VBT-B</b> <b>VBT-HD</b> <b>VBT-HDE</b> <b>VBT-E</b>	1210	Sleeve	36	-	65	55	03.200.75.06.0	2

<sup>1)</sup> no longer available

# 8 Rear hanger brackets

## 8.2 Spare parts for rear hanger brackets

### 8.2.2 Supports, sliders and attachment parts

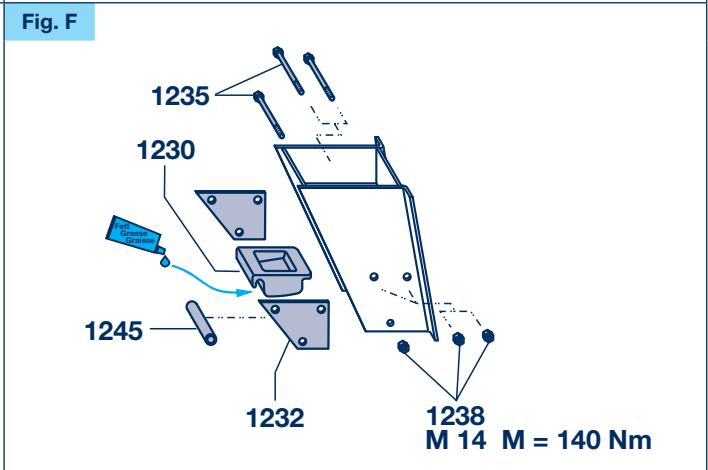
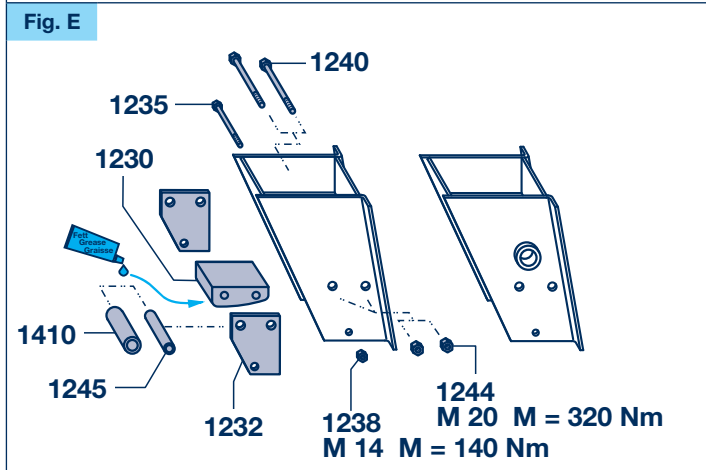
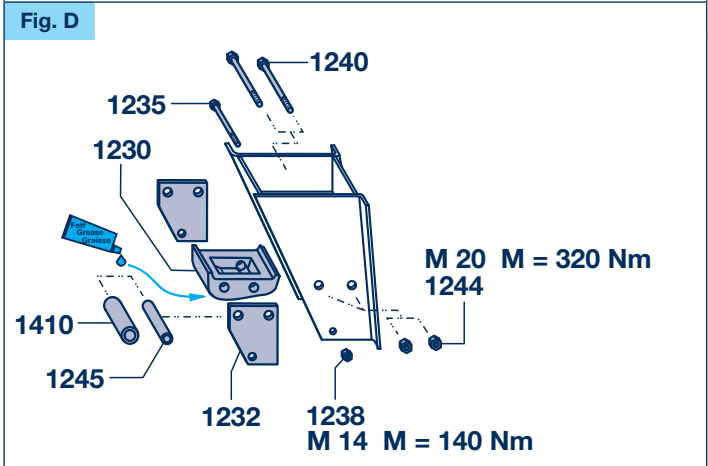
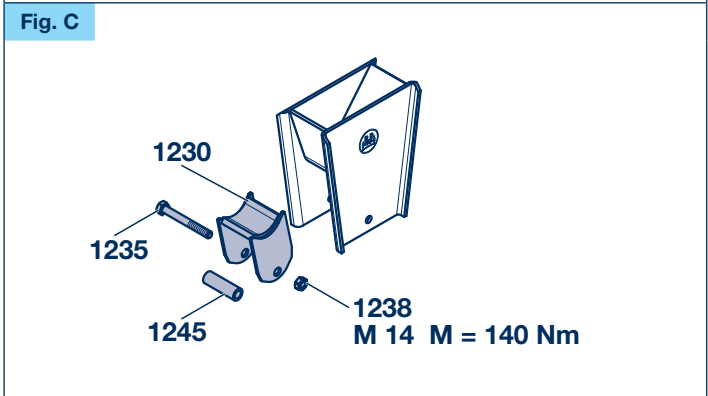
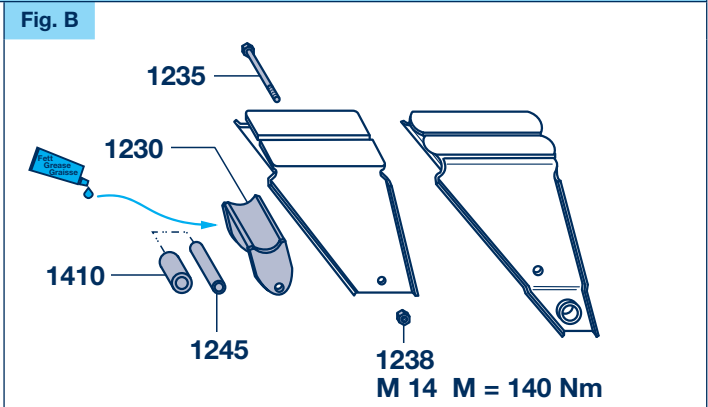
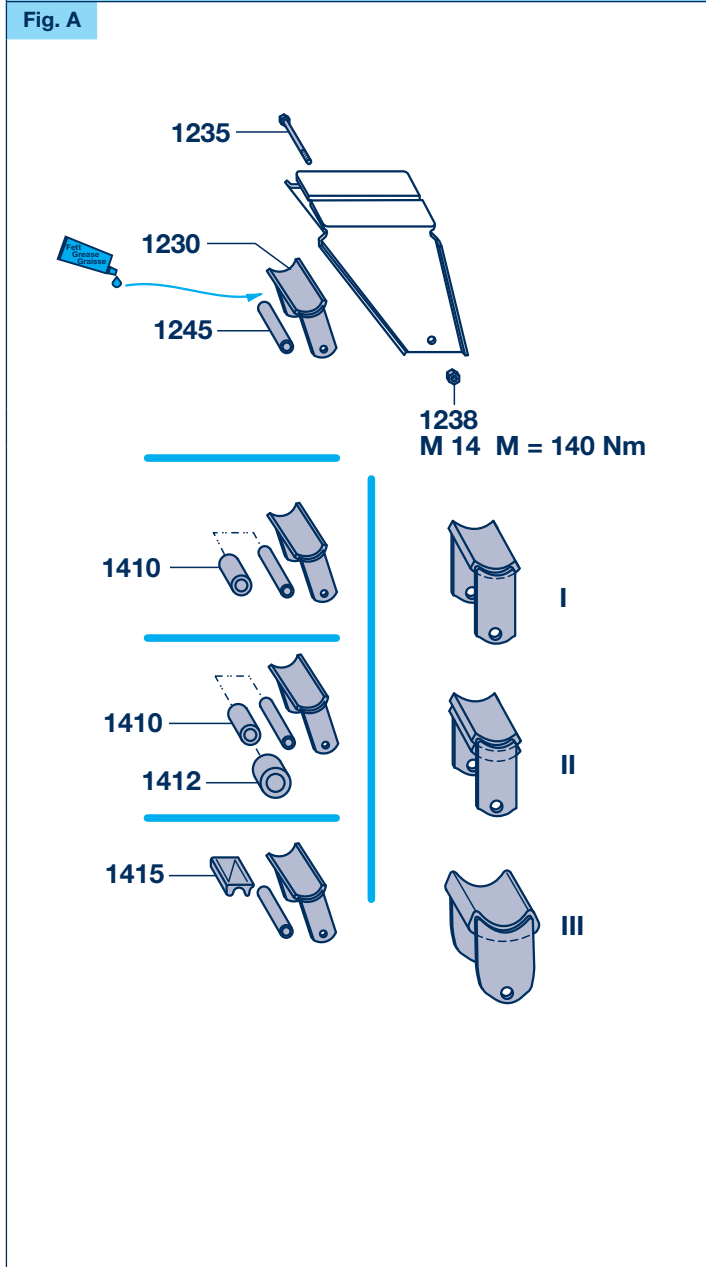

#### Supports, sliders and attachment parts



# Rear hanger brackets 8

## Spare parts for rear hanger brackets 8.2

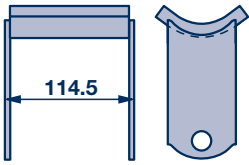
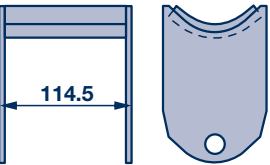
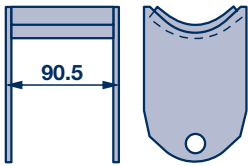
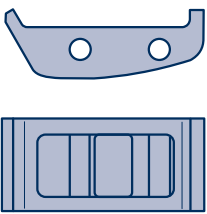
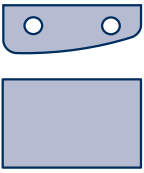
### Supports, sliders and attachment parts 8.2.2

Supports, sliders and attachment parts					
	Series	Item	Designation	Dimension	BPW Code no.
<b>Fig. A</b> 	<b>VB-K</b> <b>VB-KN</b> <b>VB-KE</b> <b>VBT-K</b> <b>VBT-KE</b>	1230	Support ( normal I )		05.189.04.70.0
			Support ( reinforced II )		05.189.05.22.0 <sup>1)</sup>
			Support ( solid III )		05.189.05.97.0
		1235	Hexagon screw	M 14 x 140 / 931-8.8	02.5022.09.80
		1238	Lock nut	M 14-8	02.5273.14.82
		1245	Tube	Ø 16 / 25 x 103	03.300.73.12.0
<b>Fig. B</b> 	<b>VB-L</b> <b>VB-LE</b> <b>VBT-L</b> <b>VBT-LE</b> <b>VB-M</b> <b>VB-ME</b> <b>VBT-M</b>	1230	Support		05.189.05.75.0
		1235	Hexagon screw	M 14 x 140 / 931-8.8	02.5022.09.80
		1238	Lock nut	M 14-8	02.5273.14.82
		1245	Tube	Ø 16 / 25 x 103	03.300.73.12.0
<b>Fig. C</b> 	<b>VB M ECO Cargo</b> <b>VBN M ECO Cargo</b> <b>VB ME ECO Cargo</b>	1230	Support		05.189.16.07.0
		1235	Hexagon screw	M 14 x 120	02.5022.12.80
		1238	Lock nut	M 14-8	02.5273.14.82
		1245	Tube	Ø 16 / 25 x 79	03.300.73.42.0
<b>Fig. D</b> 	<b>VB</b> <b>VB-B</b> <b>VB-E</b> <b>VB-HD</b> <b>VB-HDE</b>	1230	Block		03.221.89.05.0
		1232	Plate		03.285.45.08.0
		1235	Hexagon screw	M 14 x 150 / 931-8.8	02.5022.10.80
		1238	Lock nut	M 14-8	02.5273.14.82
		1240	Hexagon screw	M 20 x 160 / 931-8.8	02.5023.09.82
		1244	Lock nut	VM 20 / 980-8	02.5220.50.82
		1245	Tube	Ø 14.8 / 20 x 103	03.300.72.05.0
<b>Fig. E</b> 	<b>VBT</b> <b>VBT-B</b> <b>VBT-E</b>	1230	Block		03.221.79.01.0
		1232	Plate		03.285.45.08.0
		1235	Hexagon screw	M 14 x 150 / 931-8.8	02.5022.10.80
		1238	Lock nut	M 14-8	02.5273.14.82
		1240	Hexagon screw	M 20 x 160 / 931-8.8	02.5023.09.82
		1244	Lock nut	VM 20 / 980-8	02.5220.50.82
		1245	Tube	Ø 14.8 / 20 x 103	03.300.72.05.0
<b>Fig. F</b> 	<b>VB-C</b> <b>VBT-C</b>	1230	Slider		03.181.40.11.0
		1232	Plate		03.285.36.01.0
		1235	Hexagon screw	M 14 x 140 / 931-8.8	02.5022.09.80
		1238	Lock nut	M 14-8	02.5273.14.82
		1245	Tube	Ø 16 / 25 x 106	03.300.73.21.0
Silent block bushes					
		1410	Rubber roll	Ø 20 / 40 x 80	02.1205.02.00
			Bush	Ø 20 / 80 x 80	03.113.90.11.0
				Ø 25 / 80 x 80	03.113.90.05.0
		1412	Bush	Ø 40 / 80 x 80	03.113.94.04.0
		1415	Slider		03.181.90.10.0 <sup>1)</sup>

<sup>1)</sup> no longer available

# 9 Supports for VBT

## Supports for VBT

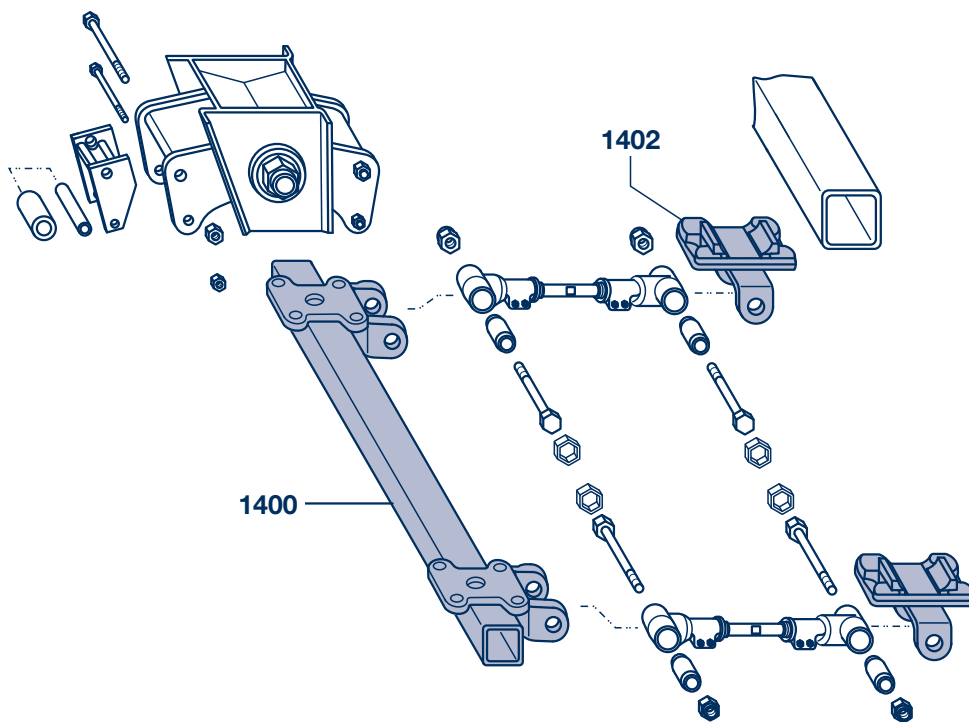
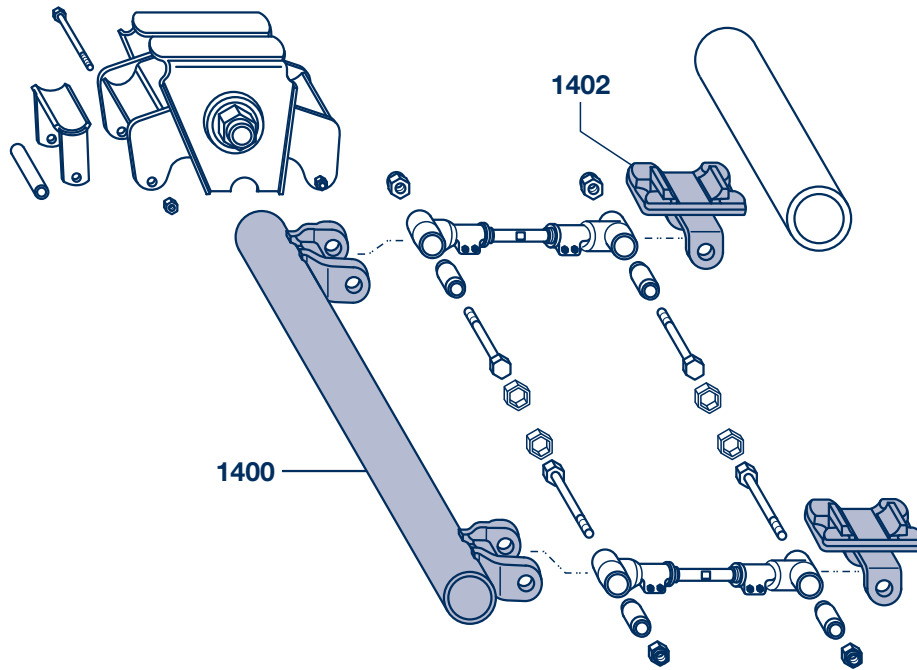

# Supports for VBT 9

Supports for VBT										
	Item	Designation	Fig.	Dimension					BPW Code no.	
				d	D	FM	L	B		
	<b>VBT</b>									
	1400	Support	a	30	Ø 101	858	673	486	05.189.07.57.0	
						980	797	610	05.189.05.74.0	
						1000	817	630	05.189.06.40.0	
						1024	841	654	05.189.07.17.0	
						1100	917	730	05.189.05.73.0	
			d		c	□ 120	900	1098	560	05.189.03.51.0
							980	1178	590	05.189.11.34.0
							1100	1298	710	05.189.02.68.0
							1150	1368	760	05.189.05.51.0
							1200	1388	810	05.189.13.31.0
				1300			1518	910	05.189.03.14.0	
				1400			1588	1010	05.189.02.81.0	
				1500			1688	1110	05.189.10.91.0	
				1580	1778	1190	05.189.14.05.0			
				1650	1850	1260	05.189.06.03.0			
				1780	1978	1390	05.189.06.04.0			
	FM = Spring centre									
	Item	Designation	Fig.	Dimension					BPW Code no.	
				d	D	B	H	X		
	<b>VBT (Support welded under the axle beam)</b>									
	1402	Support	e	30	□ 120	140	70	69	05.189.02.12.0	
						140	78		05.189.03.33.0 <sup>1)</sup>	
					□ 150	130	78		05.189.03.52.0	
			150			78	05.189.02.69.0			
			f		Ø 127	130	70		05.189.04.54.0	
						164	70		05.189.02.10.0	
				175	78	05.189.04.94.0 <sup>1)</sup>				

<sup>1)</sup> no longer available

# 10 Stabilizers

## U-Stabilizer

### U-Stabilizer

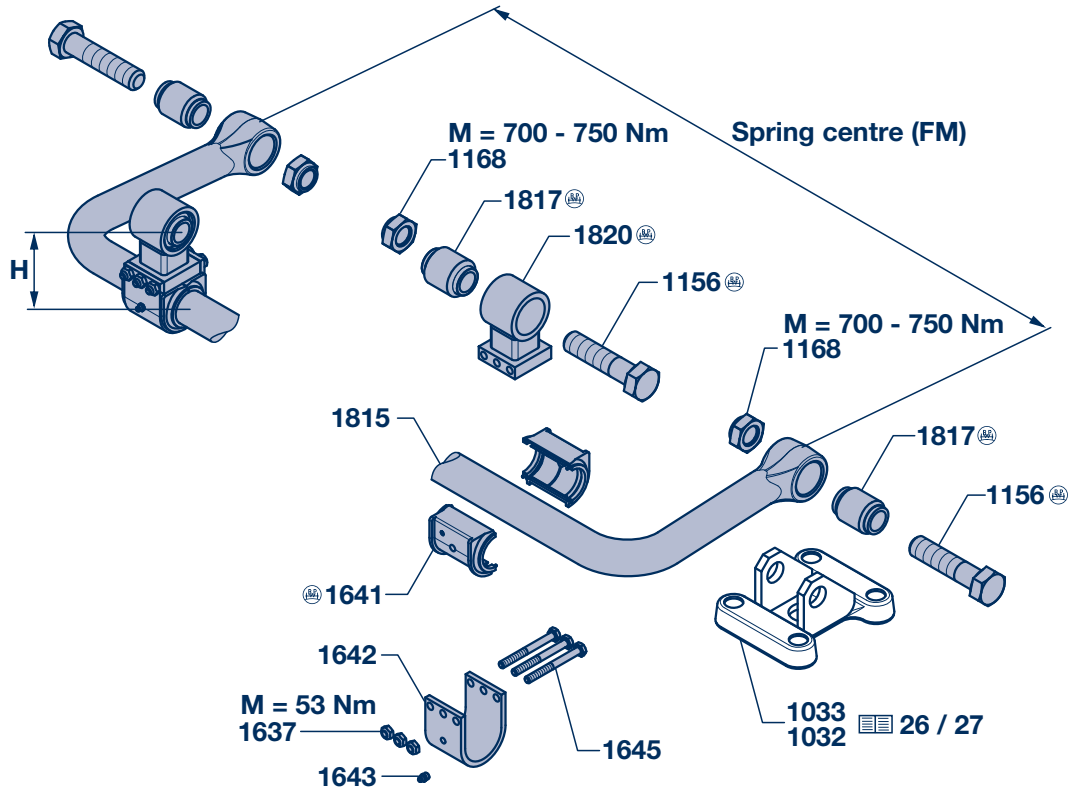

Item	Designation	Dimension	BPW Code no.	
1156	Screw	M 30 x 130-8.8	03.340.15.26.0	
1168	Lock nut	M 30	03.260.15.01.0	
1637	Lock nut	VM 10 / 980	02.5220.10.82	
1641	Bush, incl. seal	Ø 50 / 70 x 94	05.801.50.35.0	
1642	Shaped plate		03.160.56.01.0	
1643	Grease nipple	AM 10 x 1 / 71412	02.6802.03.50	
1645	Hexagon screw	M 10 x 100 - 10.9	02.5021.54.11	
				<b>Bush ( Item 1817 )</b>
1815	U-Stabilizer incl. item 1817	FM = 900	05.114.98.18.0	05.113.96.06.0 Ø 30 / 52.6 x 68
		FM = 980	05.114.98.19.0	
		FM = 1100	05.114.98.20.0	
		FM = 1200	05.114.98.21.0	
		FM = 1300	05.114.98.22.0	
1817	Bush	Ø 30 / 52.6 x 68	05.113.96.06.0	
		Ø 30 / 60 x 68	05.113.96.05.0	
				<b>Bush ( Item 1817 )</b>
1820	Support incl. item 1817	H = 120	05.189.01.78.0 <sup>1)</sup>	05.113.96.06.0 Ø 30 / 52.6 x 68
		H = 75	05.189.15.73.0	
		H = 180	05.189.03.97.0	
		H = 275	05.189.02.16.0	
		H = 395	05.189.03.99.0	
				05.113.96.05.0 Ø 30 / 60 x 68

<sup>1)</sup> Replaced by 05.189.15.73.0

# Lubrication and maintenance work 11

## Lubrication and maintenance work (Overview)

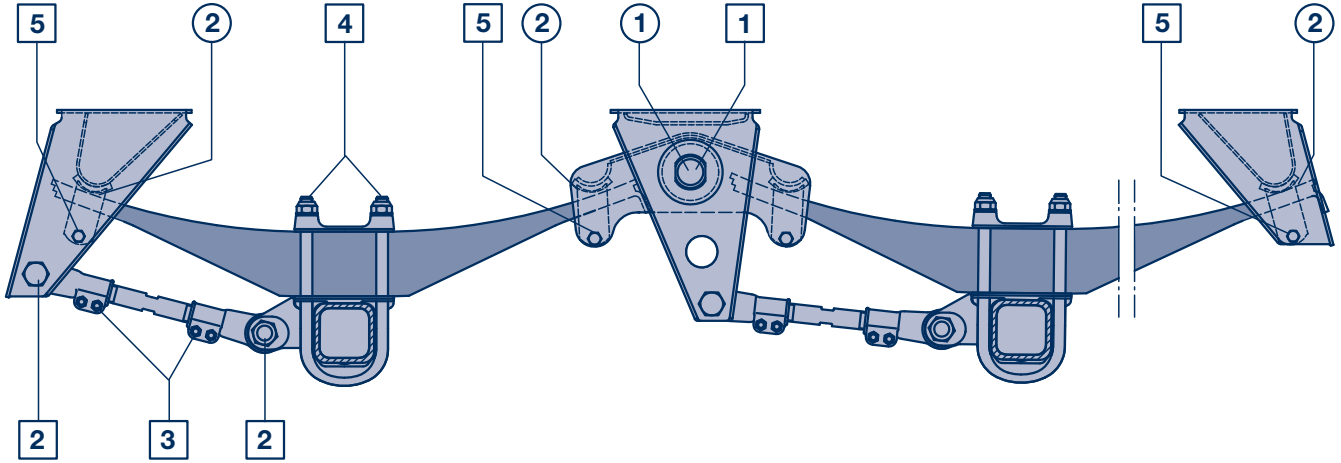

<input type="radio"/> <b>Lubricate</b> <input type="checkbox"/> <b>Maintenance</b>	initially after 2 weeks	very 6 weeks	every 26 weeks (twice annually) <sup>1)</sup>
① Grease bearings (suspension type E). (Not applicable in the case of rubber / steel bushes)	<input type="radio"/> <sup>1)</sup>	<input type="radio"/> <sup>1)</sup>	
② Slightly grease the slide elements / slide ends of leaf springs.	<input type="radio"/>	<input type="radio"/>	
- Visual inspections Check all component parts for wear and damage.			<input type="checkbox"/>
① Check threaded bolts on equalizing beam bearing for tightness. - 12 t axle load    M 42 x 3    M = 1100 Nm VB ECO Cargo    M 42 x 3    M = 1300 Nm 13 t - axle load    M 42 x 3    M = 1700 Nm M 48 x 3    M = 1250 Nm			<input type="checkbox"/>
② Check axle guide linkage screws for tightness using a torque wrench. VB ECO Cargo    M 24        M = 650 Nm M 30        M = 725 Nm M 36        M = 1425 Nm			<input type="checkbox"/>
③ Check connecting rod clamping screws for tightness. M 12-8.8    M = 66 Nm M 14-8.8    M = 140 Nm			<input type="checkbox"/>
④ Check spring U-bolts for tightness using a torque wrench. M 24        M = 600 - 650 Nm	<input type="checkbox"/>		<input type="checkbox"/>
⑤ Check slide elements for tightness. M 14-8.8    M = 140 Nm M 20-8.8    M = 320 Nm VB ECO Cargo    M 20-8.8    M = 405 Nm			<input type="checkbox"/>

<sup>1)</sup> under extreme conditions, with more frequency.

# Notices



---

# Notices

**BPW is a globally leading manufacturer of intelligent running gear systems for trailers and semi-trailers. As an international mobility and system partner, we offer a wide range of solutions for the transport industry from a single source, from axle to suspension and brake to user-friendly telematics applications.**

**We thereby ensure outstanding transparency in loading and transport processes and facilitate efficient fleet management. Today, the well-established brand represents an international corporation with a wide product and service portfolio for the commercial vehicle industry. Offering running gear systems, telematics, lighting systems, composite solutions and trailer superstructures, BPW is the right system partner for automotive manufacturers.**

**BPW, the owner-operated company, consistently pursues one target: To always give you exactly the solution which will pay off. To this end, we focus our attention on uncompromising quality for high reliability and service life, weight and time-saving concepts for low operating and maintenance costs as well as personal customer service and a close-knit service network for quick and direct support. You can be sure that with your international mobility partner BPW, you always use the most efficient method.**

# Your partner on the path to economic viability



**BPW Bergische Achsen Kommanditgesellschaft**

Postbox 12 80 · 51656 Wiehl, Germany · Phone +49 (0) 2262 78-0  
info@bpw.de · [www.bpw.de](http://www.bpw.de)