

Installation and operating instructions

Active Reverse Control



Valid: 01/01/2024

5th edition

Subject to change without notice.

Current versions and additional information can be found online at www.bpw.de.

Contents 1

◎ 1	Safety instructions	Page 3
1.1	Safety regulations	Page 4
1.2	Safety instructions	Page 5
◎ 2	System overview	Page 6
2.1	How it works	Page 6
2.2	System components	Page 7
2.2.1	BPW ARC control and hydraulic unit	Page 8
2.2.2	Electrical lines between self-steering axle and ARC control and hydraulic unit	Page 8
2.2.3	BPW self-steering axle (LL) with steering cylinder and sensors	Page 9
2.2.4	Warning lamp	Page 9
2.2.5	Hydraulic lines (optional from BPW)	Page 9
2.2.6	High-power line (for trailers, optional from BPW)	Page 10
2.2.7	Remote control	Page 10
2.2.8	Adding a new remote control	Page 12
2.2.9	EBS connection cable set	Page 13
2.2.10	Using the BPW ARC app	Page 13
2.3	Scope of delivery	Page 14
2.4	Technical data – BPW Active Reverse Control	Page 15
2.5	Possible axle arrangement with BPW Active Reverse Control	Page 16
◎ 3	Installation	Page 17
3.1	Installation of the control and hydraulic line	Page 17
3.2	Power supply to control and hydraulic unit	Page 18
3.2.1	High power for the electric motor	Page 18
3.2.2	Low current power source for the control electronics	Page 19
3.2.3	EBS connection and programming of ISS interface	Page 19
3.3	Installing the hydraulic hoses	Page 20
3.4	Cable installation	Page 21
3.5	Installing the warning lamp	Page 21
3.6	Deactivating the steering lock of the LL axle during reversing manoeuvres	Page 22
3.7	Radio receiver	Page 24
3.8	Wiring diagram	Page 25
3.9	Recommendations from preparing the high-power supply for the truck	Page 26
◎ 4	Commissioning	Page 28
4.1	Oil filling	Page 28
4.2	Checking the function lights in the electronic control unit	Page 29
4.3	Selecting the configuration	Page 31
4.3.1	Selecting a configuration with the BPW ARC app	Page 34
4.3.2	Selecting a configuration using the remote control	Page 34
4.4	Air-bleeding	Page 35
4.4.1	Bleeding using a smartphone application	Page 35
4.4.2	Bleeding using the remote control	Page 35
4.5	Setting the maximum steering angles	Page 36
◎ 5	Maintenance	Page 37
5.1	Diagnostics	Page 37
5.2	Diagnostics - Warnings	Page 38
◎ 6	Maintenance intervals	Page 52
◎ 7	Safety and the environment	Page 53

1 Safety regulations, safety instructions

1.1 Safety regulations

- All work must be performed by trained mechanics at qualified service centres and authorised specialist companies who have access to all relevant tools and have acquired the know-how required for this work. Anyone who performs maintenance and repair work must be trained in automotive mechanics and already have experience in repairing drawbar trailers and semi-trailers. Anyone who performs brake work must be trained in brake systems.
 - Comply with local safety regulations.
 - The relevant operation and service regulations as well as safety regulations of the vehicle manufacturer and of the manufacturers of other vehicle parts must be adhered to.
 - The vehicle must be prevented from moving during repair work. Please observe the relevant safety regulations for repair work on commercial vehicles, in particular the safety regulations for jacking up and securing the vehicle.
 - During repair work, make sure that the brake is not inadvertently operated. The brake must be in the released condition.
 - Do not perform repair work unless wearing protective clothing (gloves, safety boots, safety goggles, etc.) and using the recommended tools.
 - Before carrying out repair work on the vehicle, such as welding work, the ARC must be switched off and all electrical lines to the ARC disconnected and the hydraulic lines depressurised.
 - Work on the brake outside of the vehicle must be carried out with the brake clamped in a device, such as a vice.
 - Only use recommended tools.
 - When removing the brake caliper, only touch it on the sides with your hands to avoid crushing your fingers.
 - A second mechanic must provide assistance when working with heavy components (steering pivots, brake discs, brake drums or brake disassembly/assembly).
 - All air lines and components must be depressurised before opening.
 - Following each repair, perform a function check or a test drive in order to make sure that the brakes are functioning correctly. New brake linings only have maximum effect after a few braking actions. Avoid hard braking.
 - All exchanged components must be reused or disposed of in accordance with the applicable environmental regulations, laws and directives.
 - The brake caliper with the clamping unit must not be opened. The fixing screws of the cover plate as well as the bolt in the area of the brake lever must not be unscrewed or released.
 - The remaining thickness of the brake lining and the condition of the brake disc or brake drum must be visually inspected at regular intervals, depending on the way in which the vehicle is used (see BPW maintenance instructions).
 - Tighten screws and nuts to the prescribed tightening torque.
 - The tyre valve must be positioned far enough away from the brake caliper to prevent it and the tyre from becoming damaged.
 - The hydraulic oil is under pressure. Wear safety goggles for all air-bleeding procedures. Use air-bleeding screws (e.g. Minimess) and collect the oil in a closed container.
 - The BPW ARC auxiliary steering has an effect on the driving characteristics when reversing. Always manoeuvre with caution.
-

Safety instructions 1.2

This installation and operating instructions contains different types of safety instructions, each of which is marked by an icon and a signal word. The signal word describes the severity of the potential danger.



Warning!

Possible potential danger of serious or fatal injury (severe injury or death).

Caution!

Possible dangerous situation (minor injury or damage to property).



Repair guide!

Warning of damage to property or consequential damage if these instructions are not observed.



Note!

Application hints and special useful information.

It is essential that maintenance is carried out in accordance with the prescribed intervals in order to maintain the safe operation and road safety of the vehicle.

Rectification of any defects which are discovered or replacement of worn parts should be carried out by a BPW Service Centre or BPW Direct Service Partner, unless the vehicle owner has the required specialist personnel, the required technical facilities and workshop manuals or possesses an official certificate to perform interim inspections or special brake inspections.

When installing spare parts, it is strongly recommended that only original BPW components are used. Parts authorised by BPW for trailer axles and axle units are regularly subjected to special inspections. BPW accepts product responsibility for such parts.

BPW is unable to determine whether all third party products can be used with BPW trailer axles and axle units without any safety risk; this applies even if an authorised testing organisation has accepted the product.

The warranty becomes null and void if spare parts other than original BPW parts are used for warranty work.

2 System overview

2.1 How it works

BPW Active Reverse Control (ARC) is an electrohydraulic additional steering system for BPW self-steering axles. The additional steering system automatically steers the self-steering axle backwards during reversing maneuvering operations. As a standard solution, it is now also possible to steer the self-steering axle manually with the remote control up to 10 km/h when driving forwards in manoeuvring mode. The control process is electronic, the steering process is hydraulic.

The ARC control and hydraulic unit (1) with hydraulic reservoir includes a sensor that detects lateral acceleration, and hence the trailer movement, when reversing in manoeuvring mode. The steering axle is controlled on the basis of this signal by means of an intelligent software solution.

The BPW self-steering axle (2) has three integrated sensors. The BPW speed and direction sensor (DDS) (2a) on the left wheel end sends a signal to the control unit when the wheels roll backwards. The linear position sensor (2b) integrated into the steering cylinder relays the information about the steering angle. The proximity switch (2c) on the steering lock unit checks whether the lock of the self-steering axle is disabled. If the axle is locked, the additional steering system will not activate.

Another input parameter is the reversing light signal. The input signals from DDS sensor and reversing light are taken into account for reversing manoeuvres. These signals are prerequisites for the activation of the steering system. If these two signals are active, the trailer is moving sideways and the steering axle can be steered freely, the steering system activates. The software calculates the required steering angle and controls the hydraulic unit and hence the steering cylinder accordingly. During the reversing manoeuvre, the steering angle of the self-steering axle is continuously monitored by the displacement sensor integrated into the steering cylinder and corrected by the software as and when required.

The sensor information is transmitted between self-steering axle and ARC control and hydraulic unit via the electrical lines (3). The steering is guaranteed by a closed loop hydraulic system. The truck is not required to have a hydraulic system, since hydraulic components are positioned in the control and hydraulic unit (1). The power supply to the hydraulic unit (1) must be provided either by the tractor unit battery or by a trailer battery by means of power cables (6).

The additional steering system can also be controlled manually via a remote control (7). The system has a self-diagnostic function, which alerts the driver via an illuminated warning lamp (4) if the system has a mal function.

System overview 2

System components 2.2

The system consists of the following components:

- ① BPW ARC control and hydraulic unit
- ② BPW self-steering axle (LL) with steering cylinder and sensors
 - a. BPW speed and direction sensor (in the wheel end, on the left side)
 - b. Linear position sensor (in the steering cylinder)
 - c. Proximity switch (on the steering lock unit)
- ③ Electrical lines between self-steering axle and ARC control and hydraulic unit
- ④ Warning lamp
- ⑤ Hydraulic lines (optional from BPW)
- ⑥ High-power line (optional from BPW)
- ⑦ Radio remote control
- ⑧ BPW ARC App
- ⑨ EBS connection cable set

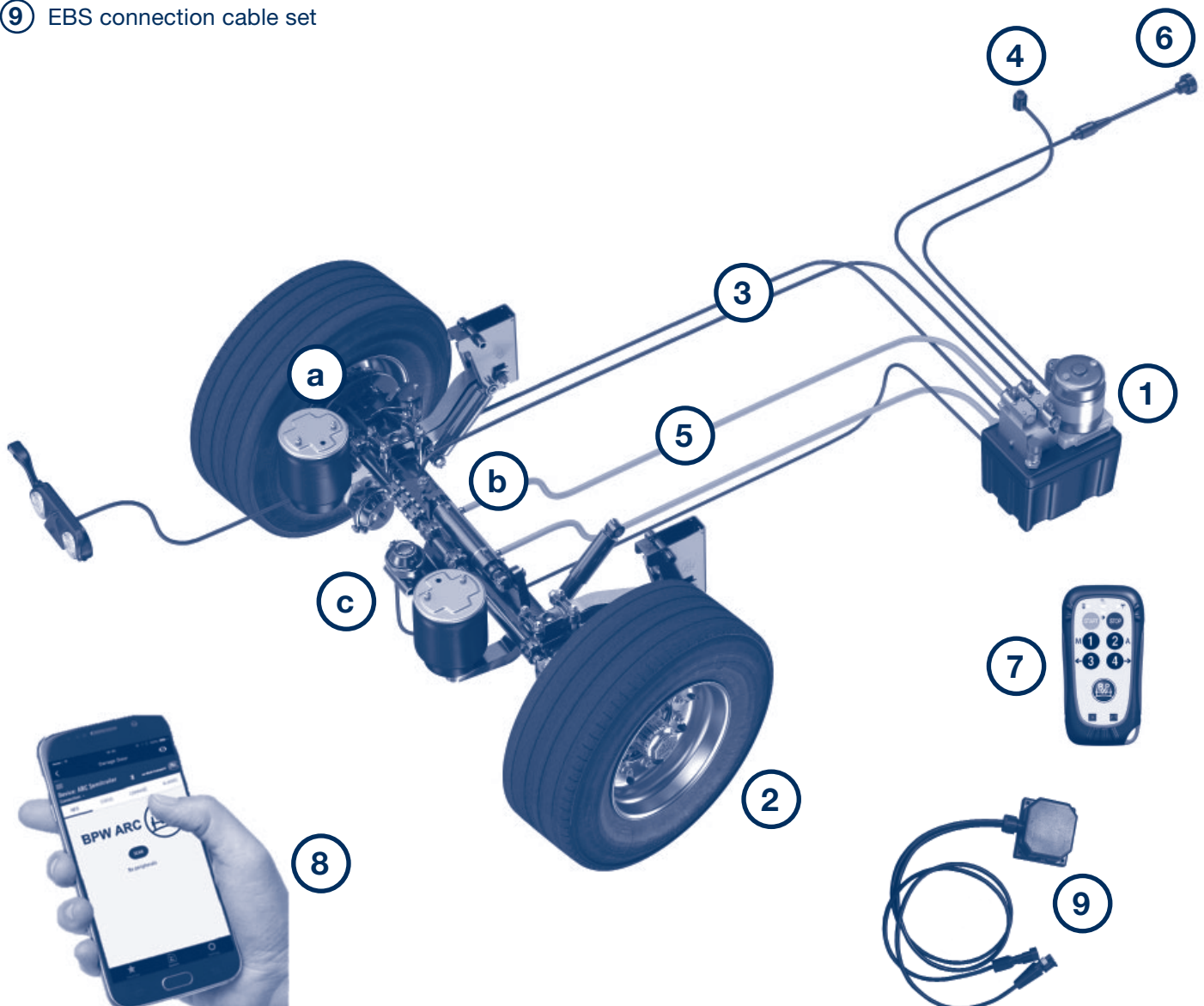

2 System overview

2.2 System components

2.2.1 BPW ARC control and hydraulic unit

The BPW ARC control and hydraulic unit includes all hydraulic and electronic components and the steering software required for controlling the self-steering axle. The BPW ARC control and hydraulic unit forms a closed hydraulic circuit, together with the BPW self-steering axle and the hydraulic hoses.

The BPW ARC control and hydraulic unit consists of the following main components:

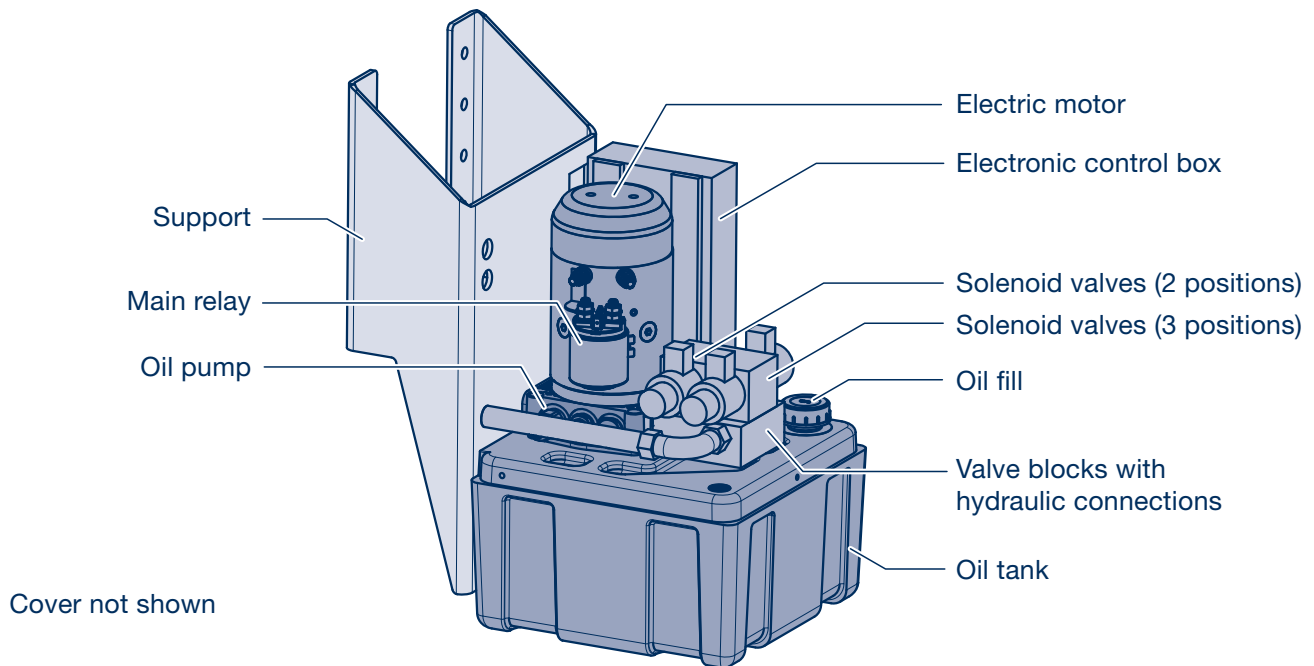

Repair guide!

There is a type plate with the BPW item and serial number on the control and hydraulic unit. This item number can be used to call up the spare parts for the control unit and the optional kits.

The rear of the control and hydraulic unit accommodates the hydraulic and electrical connections:

- Cable gland screwed joint for high-power lines
- Connections "CN1" and "CN2" for the wiring looms to the sensors, reversing light, parking light, warning lamp, PC
- Hydraulic connections "A" and "B"

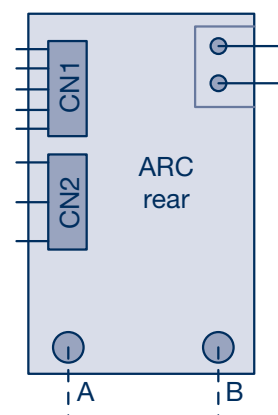

2.2.2 Electrical lines between self-steering axle and ARC control and hydraulic unit

The electrical lines must be dimensioned in accordance with the BPW specification (see chapter 3.8 Wiring diagram). Wiring looms "CN1" and "CN2" must be connected to the BPW ARC control and hydraulic unit.

System overview 2

System components 2.2

2.2.3 BPW self-steering axle (LL) with steering cylinder and sensors

The LL axles are supplied for plug&play assembly ex-works with pre-mounted steering cylinders, sensors and welded supports, insofar as the order includes the ARC additional steering system.

The BPW self-steering axle for ARC additional steering system is factory-equipped with a steering cylinder and the following sensors:

- BPW speed and direction sensor (DDS) in the wheel end, on the left side. 4-pin SuperSeal connection.
- Linear position sensor in the steering cylinder. Connection M 12.
- Proximity switch on the steering lock unit. 3-pin SuperSeal connection.

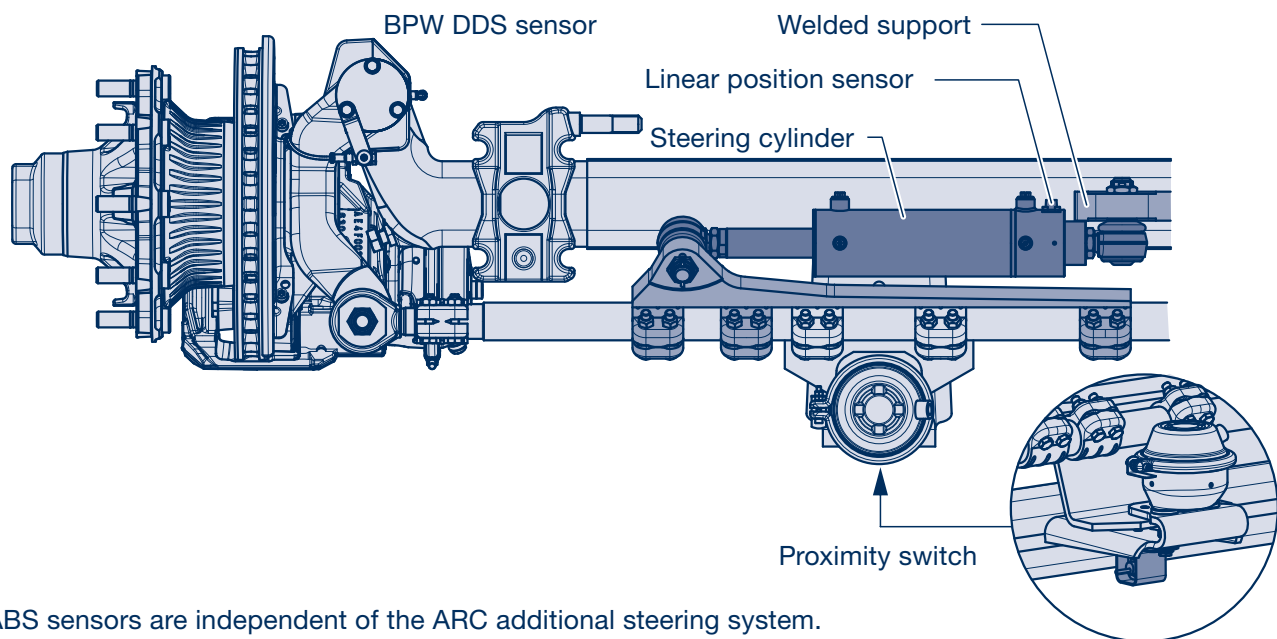

ABS sensors are independent of the ARC additional steering system. ABS sensors can be ordered in the axles prepared for ARC, as before.

2.2.4 Warning lamp

The system provides a warning lamp for the output, in order to alert the driver to potential problems with the steering system. The warning lamp has an orange-coloured light with a 2-pin SuperSeal connection. The warning lamp also signals the code of a possible anomaly, which is detected by the electronic control unit, by outputting a coded number of flashes when the control unit is subsequently switched on.

The warning lamp has several functions:

- During the steering process, the warning light flashes briefly every 5 seconds to indicate to the driver that the steering system is in operation.
- Indicates the selected ordinal number of the configuration file during the commissioning procedure. (Further information can be found in the "Commissioning" section)
- Alerts the driver if the steering system has an error or a fault. (Further information can be found in the "Maintenance" section)

2.2.5 Hydraulic lines (optional from BPW)

2x 6 m long hydraulic hoses DN12, in accordance with standards ISO 1402:1994, ISO 6605:1986, ISO 7751:1991. The operating pressure is 275 bar (minimum requirement).

2 System overview

2.2 System components

2.2.6 High-power line (for trailers, optional from BPW)

Assembled socket with 2x 10 m long lines (2P/24 V 135A, Type: NATO)

2.2.7 Remote control

The remote control is required for manual steering during forward motion. When reversing, the driver can use the remote control to switch from automatic steering to manual steering, and steer manually.

The remote control consists of three components: receiver, connection cable and remote control.

Receiver with connection cable must be fastened to the trailer chassis and to the control and hydraulic unit (further information can be found in the "Installation" section). The steering system can then be controlled remotely.

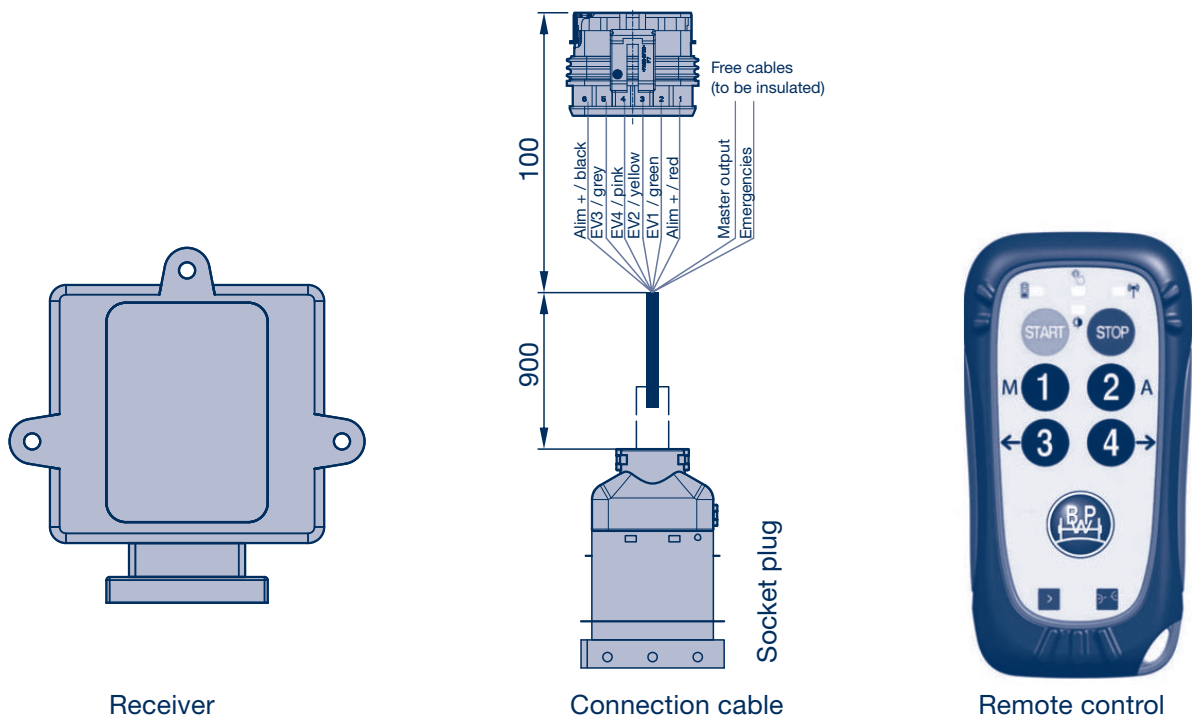

Warning!

When the remote control is used, the moving parts must be within the operator's field of vision at all times.

The remote control has the following interface:

Function button	Description	Figure
"Start"	Switches on the remote control	
"Stop"	Switches off the remote control	
"1"	Manual mode	
"2"	Automatic mode	
"3"	Steer to left	
"4"	Steer to right	

System overview 2

System components 2.2

Activates manual mode via the remote control (reversing light must be on when manual mode is activated):

- Press the "Start" function button to activate the remote control.
- Press function button "1" to switch the remote control to manual mode.
- Press function buttons "3" and "4" to steer the self-steering axle either to the left or to the right.
If this button is not pressed within 7 seconds of the motion starting, the system will return to automatic mode (in case it was pressed accidentally).

If manual mode is no longer required, press function button "2" to activate automatic mode (and exit manual mode).
If reverse gear is deactivated, the system will exit manual mode automatically.

If remote control is no longer required, press the "Stop" function button to deactivate it.

Wireless communication between remote control and receiver is indicated by the green light on the remote control.
The remote control function works with 2 AAA batteries. A weak battery status is indicated on the remote control by the red light. BPW recommends reusable batteries.

The system will exit manual mode in the following cases:

- If no steering commands are given for 1 minute, the system will return to automatic mode.
- For systems that only operate in reverse gear:
If reverse gear is disengaged, the system will return to automatic mode.
- For systems that also operate in forward gear:
If the speed exceeds 10 km/h in forward gear, the steering system is deactivated, manual mode is quit and the steering switches to self-steering.

Comments

The remote control turns off after one minute to conserve battery power. After one minute without any command in manual mode, the system switches to automatic mode by itself. If the remote control fails to respond, press the "Start" button.

The following applies to vehicles that are designed exclusively for reversing:

If the vehicle, during a manoeuvre in manual mode, rolls forwards (even though reverse gear is engaged), the steering system will remain in manual mode. Once the roll-forward movement has ended and the vehicle reverses again, the axle can continue to be steered manually.

A replacement or additional remote control (handset) can be supplied and paired at a later date. Please get in touch with BPW if you need this.



Installation instruction!

The maximum range of the remote control is 150 m in an outdoor setting and without sources of interference. Interference such as vehicle frames or metallic parts can reduce the range significantly. Therefore, if possible, the receiver should be mounted on the outside of the vehicle.

2 System overview

2.2 System components

2.2.8 Adding a new remote control – pairing

The remote control kit is supplied with a paired remote control. You can pair a new remote control with the existing receiver at any time.

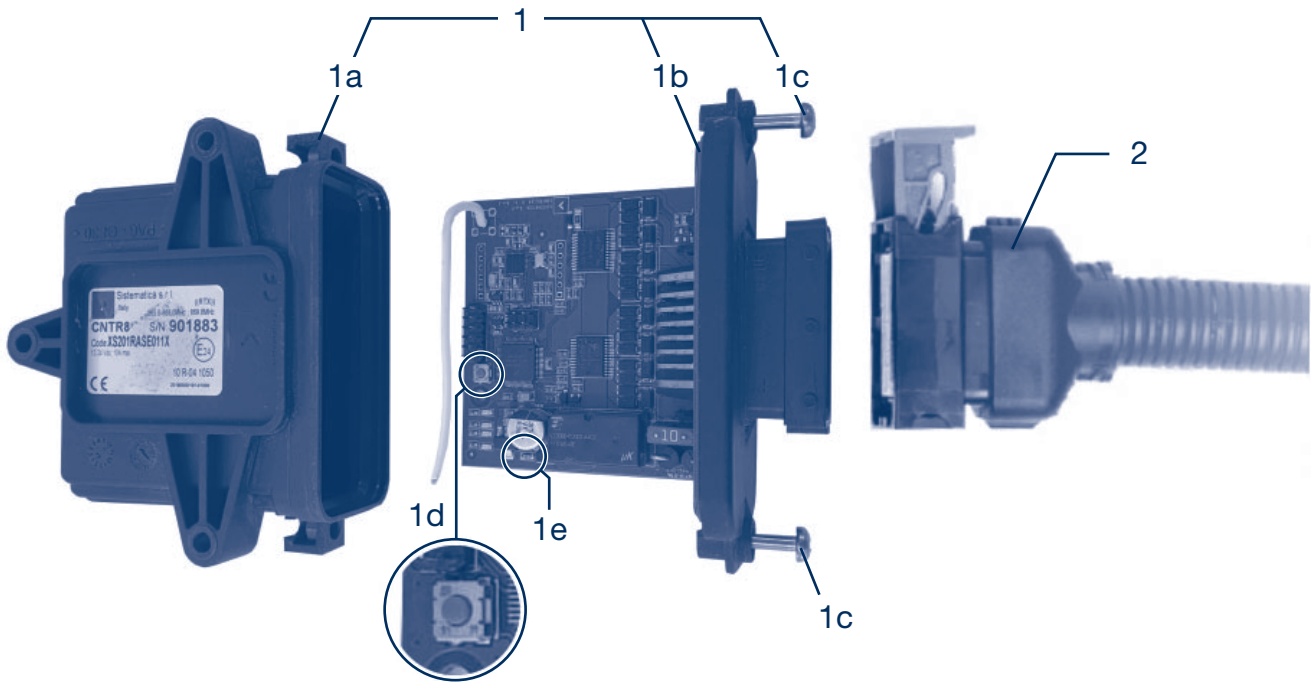

To pair a new remote control with an existing receiver, proceed as follows:

1. Disconnect the cable (2) from the radio receiver (1) to cut off the power supply.
2. Open the housing of the radio receiver by removing the two screws (1c) next to the plug and remove the electronic circuit board (1b).
3. Connect the power cable (2) to the radio receiver (1). Press and hold the button (1d) until the LED (1e) starts flashing (3 - 4 seconds). (The yellow LED on the receiver board flashes twice per second.)
4. Press the blue coding button (1d) on the electronic circuit board.
5. Then, release the coding button (1d).
6. Within 15 seconds of switching on (Start/Stop button), press any 3 buttons on the remote control at the same time (e.g.: 1, 3, 4) until the yellow LED (1e) stops flashing.
7. From this point on, the remote control is paired with the radio receiver (1). Please test the functionality of the remote control to check that it is paired correctly. To do this, remove the cover plate of the control unit to reveal the electronics box.
By pressing the buttons on the remote control (e.g. 1, 3 or 4), the corresponding LEDs in the electronics box should light up, see chapter 4.3 on page 30.
8. Disconnect the power cable (2) from the radio receiver. Slide the electronic circuit board (1a) into the housing (1b) of the radio receiver and connect it with the screws (1c) that were removed in point 2.

It is possible to use several remote controls with one radio receiver.

System overview 2

System components 2.2

2.2.9 EBS connection cable set

An EBS connection cable set is required for activating the ARC steering system when driving forwards at speeds of up to 10 km/h. This cable set must be connected to the trailer EBS system.

The EBS connection cable set consists of a 3-pin Superseal plug (with yellow seal) for connection to the ARC system – CN2 cable and a 2-pin universal socket for connection to the EBS.

Depending on the manufacturer of the EBS system, additional adapter or extension cables for the ISS speed switch may be required for connection to the EBS modulator (not included in the BPW scope of delivery).

Plug 1: Length 1m
This plug must be connected to the CEN plug of the CN2 cable.

Plug 2: The 2-pin Superseal “EBS” plug must be connected to the ISS port of the EBS using an additional adapter cable – not included in the BPW scope of delivery.

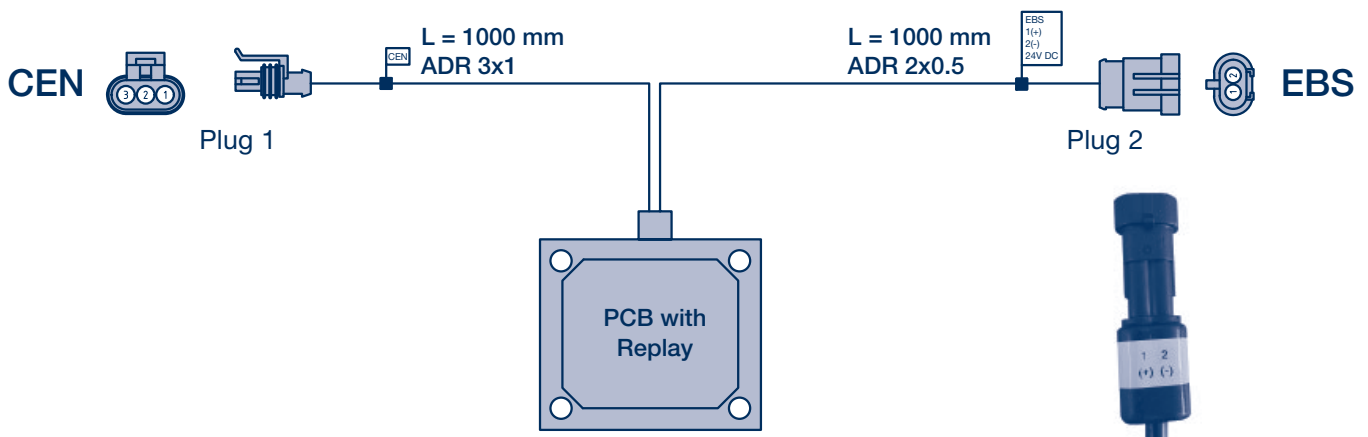

2.2.10 Using the BPW ARC app

The BPW ARC app was developed to enable simple and quick commissioning of the system as well as diagnostics. Thanks to a Bluetooth module, information about the status of the system and also notifications – such as alarms – can be accessed via the app. It is also possible to adjust the configuration settings and manually control the system while the vehicle is stationary. Please note that the app only works when the vehicle is stationary. The Bluetooth connection is automatically interrupted when the vehicle is in motion. For further details and information on how the app works, please refer to the “BPW ARC App Manual”.



Note!

Due to legal regulations, the app cannot be used for manual control while the vehicle is in motion. Use the remote control in this case.
(BPW item number of the kit: 05.801.47.10.0)

2 System overview

2.3 Scope of delivery

1. BPW self-steering axle (LL) with steering cylinder and sensors
Code number: depends on axle version

 - 2a. BPW ARC standard control and hydraulic unit, incl. electrical lines between self-steering axle and ARC control and hydraulic unit, warning lamp, EBS connection cable set, ARC remote control kit TE050 (05.801.47.10.0)
BPW code number: 05.801.46.20.0
 - 2b. BPW ARC control and hydraulic unit for ADR application, incl. electrical lines between the self-steering axle and ARC control and hydraulic unit with stainless steel cover plate, warning lamp, EBS connection cable set, ARC remote control kit TE050 (05.801.47.10.0)
BPW code number: 05.801.47.33.0
 - 2c. BPW ARC basic control and hydraulic unit – prepared for forward steering – incl. electrical lines between self-steering axle and ARC control and hydraulic unit, warning lamp
BPW code number: 05.801.46.21.0
 - 2d. ARC retrofit kit for forward steering: includes EBS connection cable set (02.4320.02.05) and ARC remote control kit TE050 (05.801.47.10.0)
BPW code number: 05.801.46.24.0

 3. Assembly kit for power line 10 m ARC (optional, for trailers only)
BPW code number: 05.801.47.11.0
Includes:
 - Mounted socket with 2x 10 m long lines (2P/24V 135 A, Type: NATO)
 - Loose cable lug M 8
 - Switch with two fixed positions for switching between the steering lock unit and the ARC

 4. Assembly kit for hydraulics 6M ARC (optional)
BPW code number: 05.801.47.12.0
Includes:
 - 2x 6 m long hydraulic hoses M 22 x 1.5
 - 4x screwed joints M 22 x 1.5 / G3/8"
 - 2x screws for air-bleeding

 5. ARC power cable mounting kit for ADR (optional, complete solution: lorry + trailer)
BPW code number: 05.801.47.71.0
Includes:
 - 2 x 15 m long cable for trailer (2P/24 V, 35 mm², with fitted plug connector, type: AK-Teck Power Hybrid)
 - 2 x 4 m long spiral cable between lorry trailer (2P/24 V, 35 mm², with fitted plug connector, type: AK-Teck Power Hybrid)
 - 2 x 5 m long cable for lorries (2P/24 V, 35 mm², with fitted plug connector, type: AK-Teck Power Hybrid)
 - Switches with two fixed positions for switching between the steering lock unit and the ARC

 6. The BPW ARC app can be downloaded free of charge in 4 languages (DE, EN, IT and FR) via the Google Play Store or the Apple App Store.
-

System overview 2

Technical data – BPW Active Reverse Control 2.4

Ask your dealer about the possible BPW steering axle module combinations.

BPW self-steering axles (LL) for BPW Active Reverse Control						
Brake type	Rim	Tyre	Axle load	Suspension	min. spring centre	max. steering angle
Disc brake TS2 4309 / 3709	R 22.5" / R 19.5"	Single	9 - 10 t	ALO / ALM / ALMT	980	12°
Disc brake TS2 4309 / 3709	R 22.5" / R 19.5"	Single	9 - 10 t	ALO / ALM	1080	18°
Drum brake SN 3020	R 17.5"	Twin	9 - 12 t	ALU	600	20°
Drum brake SN 4218	R 22,5"	Single	9 - 10 t	ALO / ALM / ALMT	980	12°
Drum brake SN 4218	R 22,5"	Single	9 - 10 t	ALO / ALM	1080	18°









Control	Electronic	
Transmission	Hydraulic	
Application	Reversing in manoeuvring mode $V < 10$ km/h, automatic and / or manual with remote control Forwards motion in shunting mode $V < 10$ km/h, manual only with remote control	
Angle sensor	Innovative sensor technology in the control unit. No angle sensor required on the King pin.	
Power supply	Voltage	24 V
	Max. current	100 A (125 A fuse)
Rated output	During normal operation	1000 - 1500 W
Dimensions	Control and hydraulic unit:	510 x 275 x 415 mm (H x W x D)
Weights	Control and hydraulic unit	28.5 kg
	Axle weight penalty	28.6 kg*
Working temperature	from -30° C to +60° C	
Oil	Mineral oil	
	Viscosity class	VG15
	Oil quantity	approx. 7.5 litre
	Working pressure	max. 180 bar

*depending on axle version

2 System overview

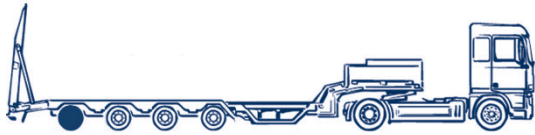
2.5 Possible axle arrangements with BPW Active Reverse Control

ARC can essentially be used wherever a self-steering axle is allowed to be used, this being based on the legal and technical conditions (in accordance with ECE R79). The ratio between rigid axle and self-steering axle must be at least 1:1.

Number of axles	Arrangement	Possible wheelbases in mm	Illustration (LL axles marked as full wheel)
2	1x rigid 1x LL	Wheelbase 1310 - 2020	 <p>Can also be shown with drawbar</p>
3	2x rigid 1x LL	Wheelbase 1: 1310 - 1810 Wheelbase 2: 1310 - 2020	 
	1x turntable 1x rigid 1x LL	Wheelbase 1310 - 1810	
4	3x rigid 1x LL	Wheelbase 1: 1310 Wheelbase 2: 1310 Wheelbase 3: 1310	
	3x rigid 1x LL	Wheelbase 1: 1310 - 1810 Wheelbase 2: 1310 - 2020 Wheelbase 3: 1310 - 2020	
5	4x rigid 1x LL	Wheelbase 1310	
	2x turntable 2x rigid 1x LL	For Tridem: Wheelbase 1: 1310 - 1810 Wheelbase 2: 1310 - 2020	
		For Boogie: Wheelbase: 1310	

Installation 3

Installing the control and hydraulic unit 3.1

The ARC control and hydraulic unit with hydraulic reservoir can be attached to any point on the vehicle frame, behind the front pivot of the trailer (king pin/drawbar/turntable) and in front of the axles.

The control and hydraulic unit must be installed in an accessible position, particularly on the side of the electronic control unit on which the LEDs are visible. The control and hydraulic unit must be permanently installed in the vertical position with the cover plate facing upwards and the oil tank facing downwards.

It is advisable to install the control and hydraulic unit in a position that is protected from water and stone chips.

Ensure the clearance at the rear of the control and hydraulic unit is adequate for the electrical cables and oil lines. The control and hydraulic unit weighs approx. 30 kg. Attach the unit accordingly with due consideration for vehicle vibrations. BPW recommends attaching the unit using at least 6x M 10 screws.

Figure 1: Semi-trailer from above:

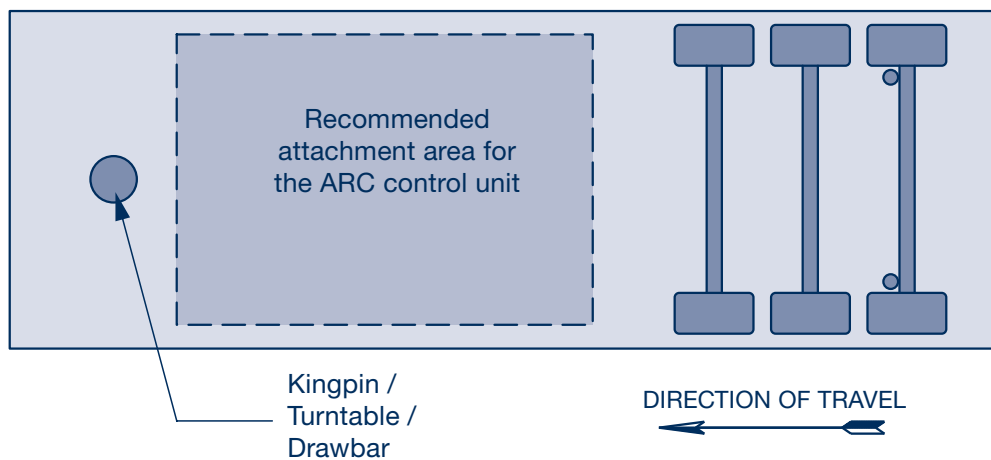

If the control and hydraulic unit cannot be positioned within the recommended attachment area (e.g. low loader trailer), it can be attached between the axles.

Figure 2: Permitted arrangements for control and hydraulic unit

Permitted installation positions for the unit - plan view

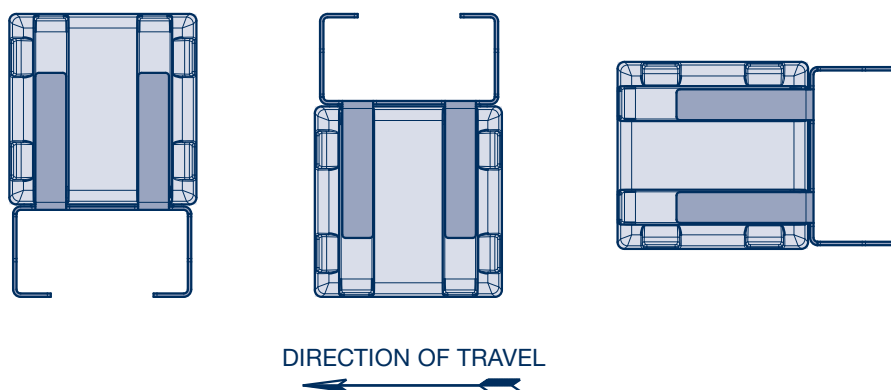

3 Installation

3.1 Installing the control and hydraulic unit

3.2 Power supply to the control and hydraulic unit

Figure 3: Control and hydraulic unit dimensions

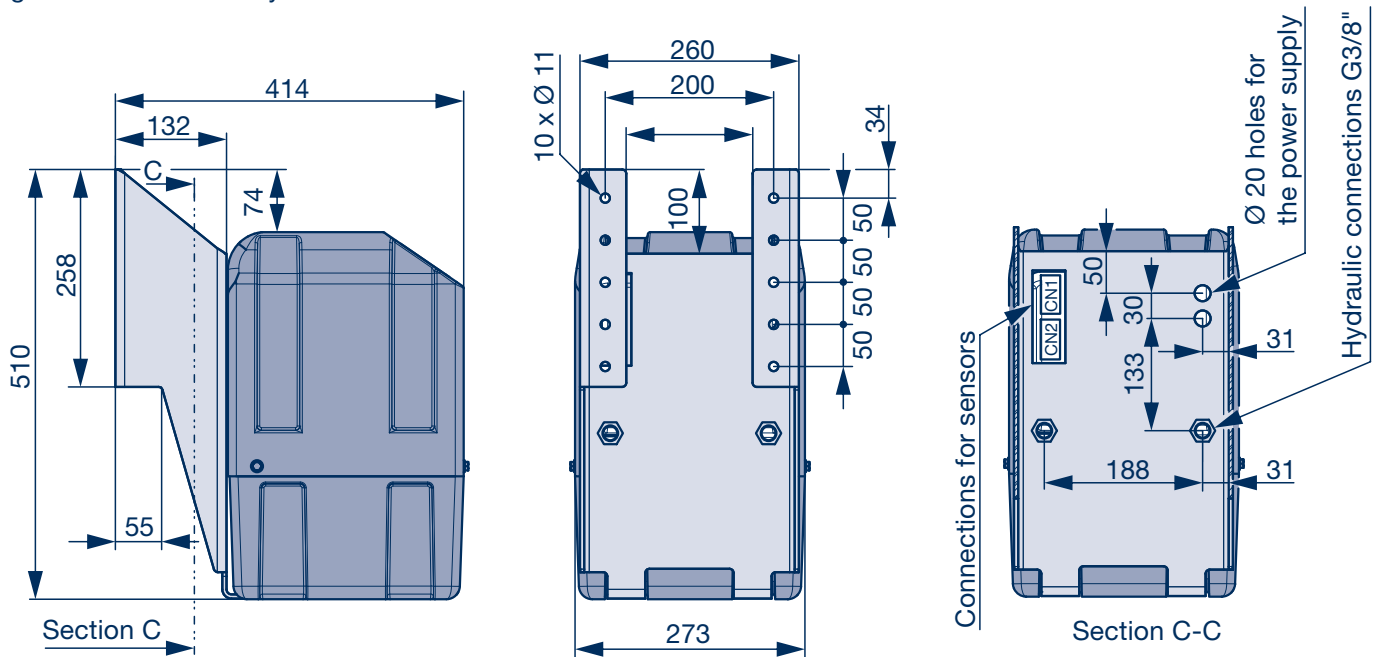

Attachment: At least 6 x M 10 screws

3.2 Power supply to the control and hydraulic unit

The ARC control and hydraulic unit is supplied from two power sources:

3.2.1 High power for the electric motor

The high power must be guaranteed by either the tractor unit battery or a trailer battery.

The high-power cable must be connected to the electric motor (negative terminal) and the relay (positive terminal) via the ARC system box.

The cable cross section must be at least 25 mm² at a length of 10 m. Cable lugs must be mounted at the end of the cables and then attached to the M8 screws on the electric motor and relay. The pre-assembled cable sets in the system box must not be removed or modified. The high-power line is optionally available.

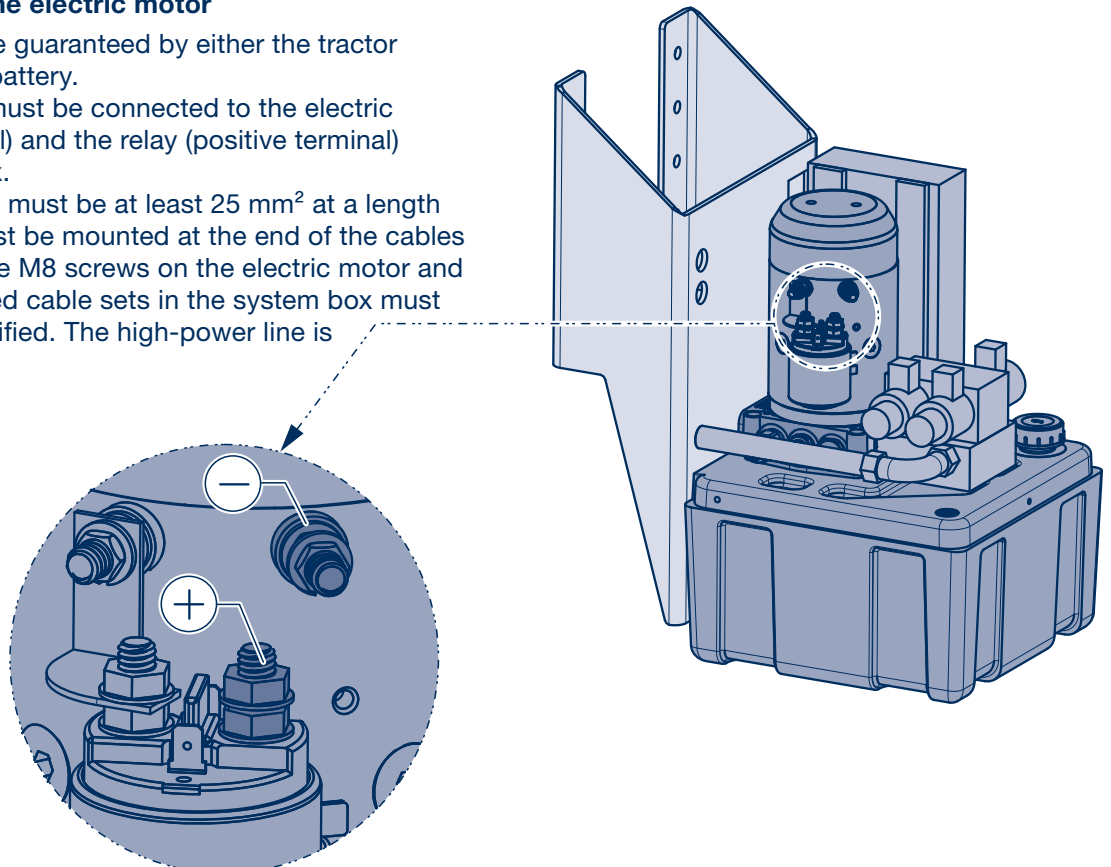

Installation 3

Power supply to the control and hydraulic unit 3.2

3.2.2 Low current power source for the control electronics:

3.2.2.1 Power supply from the truck batteries

The power supply must be guaranteed in accordance with the circuit diagram below. The operating voltage must not fall below the value of 20 V.

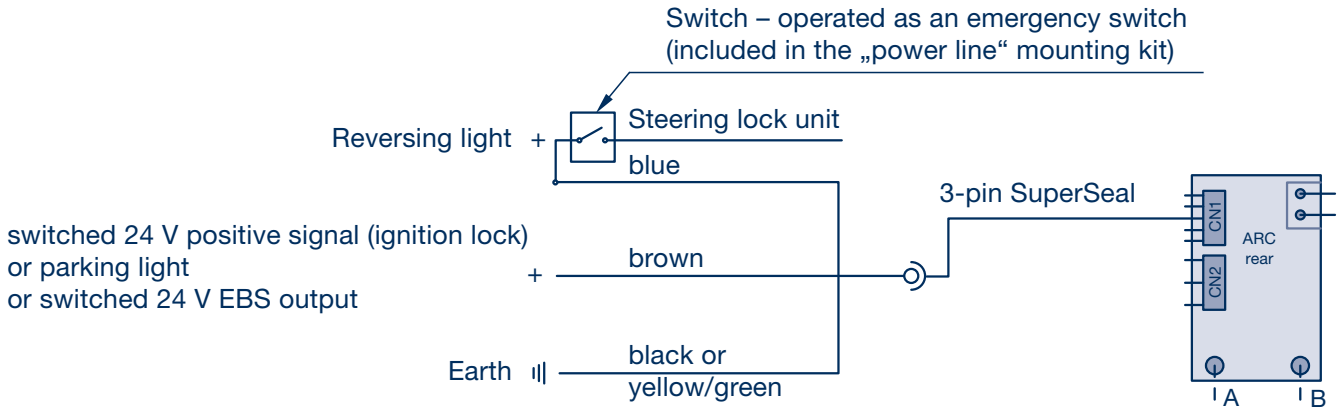

3.2.2.2 Power supply from the trailer batteries

If the ARC unit is powered by trailer batteries, two relays (not included in the BPW scope of delivery) are required.

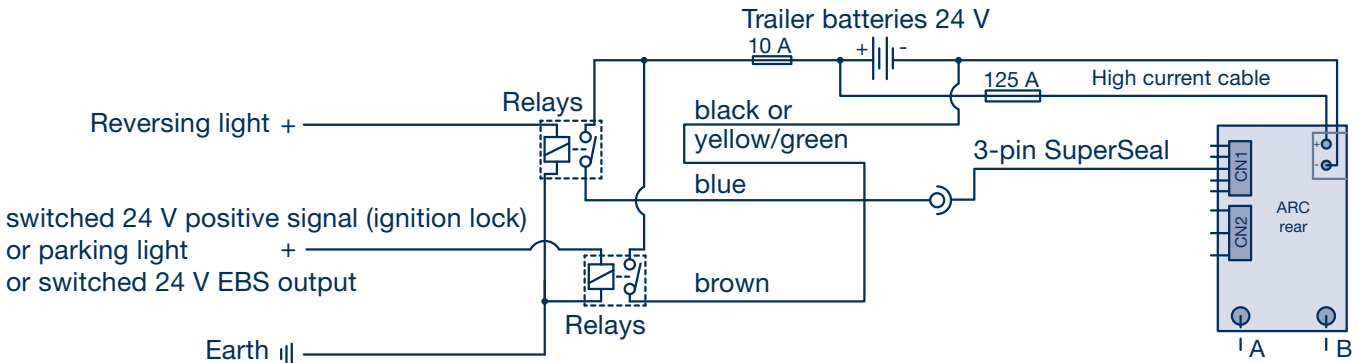

Installation and repair guide!

To avoid possible damage caused by electrostatic charging and discharging, the electrohydraulic suspension should only be installed after any finishing work, e.g. welding or painting, has been carried out. The cables should only be connected to the control unit after these activities have been completed.

3.2.3 EBS connection and programming of ISS interface

To activate the steering function when driving forwards up to 10 km/h with a remote control, ARC must be connected to the ISS (Integrated Speed Switch) interface of the EBS system. An EBS connection cable set from BPW is supplied for this purpose. Depending on the EBS manufacturer, an additional adapter cable may be required to connect the BPW EBS connection cable set to the ISS port via the 2-pin plug end. A free port must be available on the ISS modulator for this purpose. This cable is not included in the BPW scope of delivery.

The ISS output on the EBS must be programmed to supply a 24 V voltage at a speed of 0 to 10 km/h.

Caution:

Do not programme the ISS interface to a value above 10 km/h. The steering system can detect the speed using the other sensors, meaning that the system will go into warning mode and issue an error message if the ISS output is active at above 10 km/h.

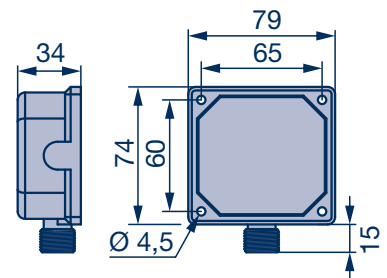

3 Installation

3.3 Installing the hydraulic hoses

3.3 Installing the hydraulic hoses

Measure the length of the hose connections to the cylinder, with due consideration for the deflection of the axle suspension. Route the piping in such a manner that twisting and tight bending is avoided. Always consider the suspension movement of the running gear (and all movements on the truck floor). Lines must be routed in the protected area in order to avoid contact with stones on the road.

The operating pressure line must be at least 275 bar. The hydraulic connections on the steering cylinder and in the hydraulic unit are prepared with G 3/8" threaded holes.



Installation and repair guide!

A correct air-bleeding procedure can be guaranteed only if the oil line connections are not mixed up.

- The outlet "**A**" of the hydraulic unit must be connected to the **cylinder head**.
- The output "**B**" of the hydraulic unit must be connected to the **cylinder bottom**.

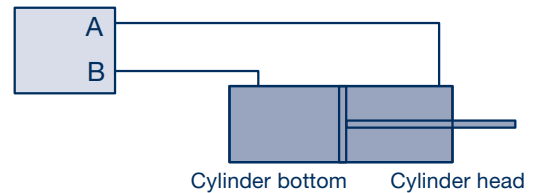

Installation and repair guide!

The internal cleaning of the oil system is fundamental to trouble-free operation without the solenoid valve becoming clogged.

Pipes and all fittings should be kept clean and clamped until they are connected.

Ensure that the hydraulic hose is the correct length. It should be designed in such a way that functional integrity is guaranteed in every suspension position.

Installation	3
Cable installation	3.4
Installing the warning lamp	3.5

3.4 Cable integration

The proper connection and protection of the cables is crucial for the reliability of the system. Water ingress and vibrations can cause cable breakage and ultimately system failures. To prevent cables becoming broken, they must be securely attached to the vehicle frame. It is therefore recommended that they are fixed using cable ties, as this permits the movements required for axle and chassis connections while guaranteeing stability at the same time.

The cables must **not** be exposed to any tensile force, twisting or tight bending. Connectors and cable screwed joints must not be under tensile load.

Their weight should never be supported by the connections. For example, the output cable of the electronic control unit (connections CN1 and CN2) must be connected to the vehicle in the vicinity of the frame.

- **Electrical cylinder connection:**
This M12 type connection with threaded ring nut must be securely fastened to prevent water from entering and destroying the connection!
- **Cables on the axles:**
The axles are subjected to high vertical vibrations. It is important that the cables are fastened at positions no more than 10 cm apart.
- **The C5 plug (DDS sensor) must be attached to its holder.** The cable must be fastened in such a way that it has no room for movement, does not vibrate due to the vertical vibration of the axle and is not stretched by the steering movement.
It is also important to keep the cable away from the rotating parts of the axle (brake disc, brake drum, wheel disc) to avoid any abrasion or damage caused by heat.
- **Between the frame and axle, the cables can be conveniently attached to the pneumatic hoses of the brakes or the pneumatic lock.**



Installation and repair guide!

When fitting the plug connections, ensure that they are attached in the correct manner.

3.5 Installing the warning lamp

The warning lamp must be mounted in a position on the semi-trailer that is easily visible from the driver's cab.

It is also possible to attach a warning light to the semi-trailer and, in addition, to prepare a warning light in the cab. In this case, the two lights have to be switched in parallel and the total power must not exceed 3 watts (not included in the BPW scope of supply).

The warning lamp must be connected according to the drawing in the chapter "3.8 Wiring diagram".

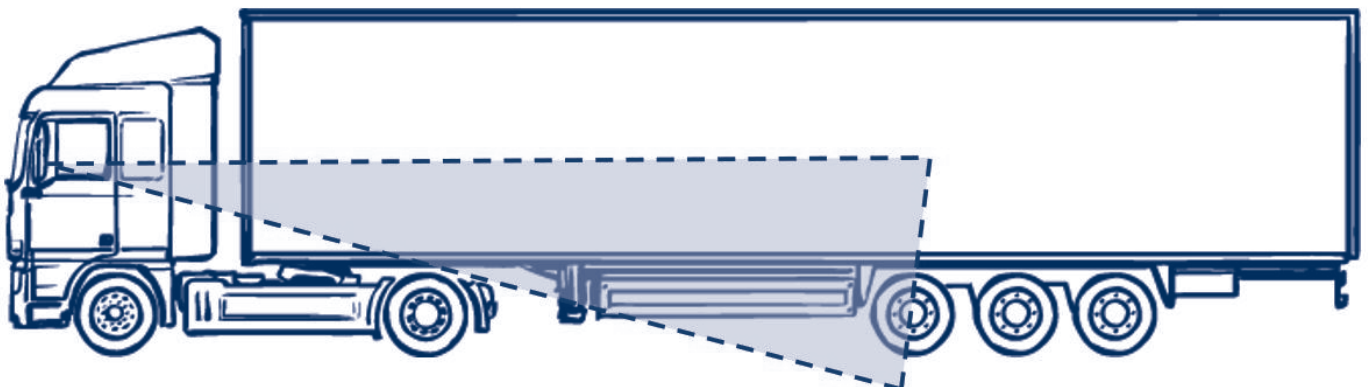

3 Installation

3.6 Deactivating the steering lock of the LL axle during reversing manoeuvres

The function of the steering lock unit on self-steering axles without ARC additional steering:

In order to avoid uncontrolled turning of the steering pivot during a reversing manoeuvre, the self-steering axle is locked by a steering lock between the axle beam and the track rod connecting the steering pivots. The steering lock is actuated by compressed air, and is usually controlled by the electronic brake system (EBS) or reversing light if reverse gear has been engaged. On a secure surface, an engaged self-steering axle mostly passes through the zero position having reversed for a few metres, meaning that the lock can engage.

The function of the steering lock unit for self-steering axles with ARC additional steering:

If the self-steering axle is equipped with ARC additional steering, the two systems are not allowed to function at the same time. This is because the axle must always be unlocked during reversing manoeuvres (lock cylinder under air pressure) for the ARC additional steering to activate. In this case, the steering lock unit will not activate during normal operation (steering axle can always be steered freely). The steering lock unit is required only in the following emergency situations:

- No power supply available on the truck
- Error or fault in the ARC additional steering.

The opened condition of the steering lock unit (= steering lock unit deactivated) can be achieved pneumatically or electronically.

Option A)

Pneumatic deactivation of the steering lock unit

Compressed air must be continuously guaranteed for the lock cylinder by an air valve (not included in the BPW scope of supply). In an emergency, the valve can be closed, the steering lock will be activated and the axle will be locked. In this case, the electrical lines must be connected in accordance with the figure in "Option A)".

Option B)

Electrical deactivation of the steering lock unit

The mechanical steering lock must be controlled via the reversing light signal. The ARC additional steering uses the reversing light signal also as an input parameter. A switch with two fixed positions (optionally available with BPW "Assembly kit power line 10M ARC") has to be installed. During normal operation, the reversing light signal is always switched to the ARC. In an emergency, the reversing light signal can be switched to the steering lock unit. In this case, electrical lines must be dimensioned in accordance with the figure in "Option B)".

Logic: No voltage on the steering lock unit
= Compressed air in the lock cylinder

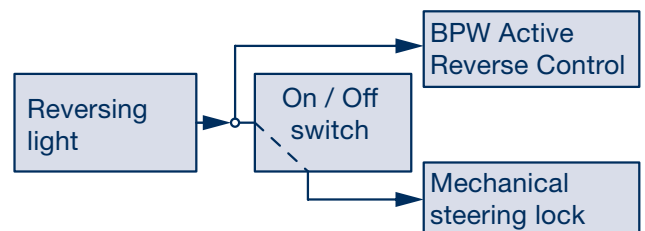
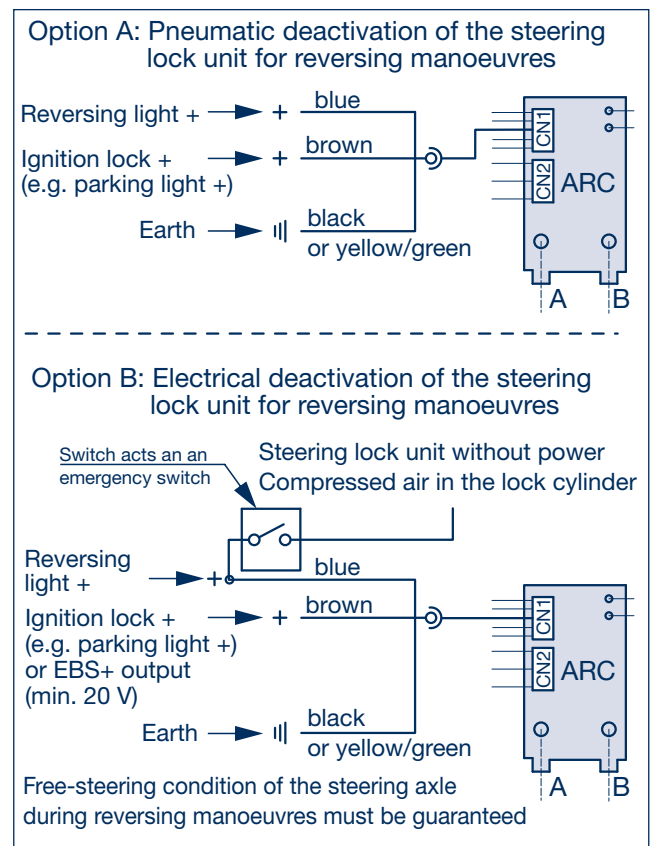

Installation 3

Deactivating the steering lock of the LL axle during reversing manoeuvres 3.6

Option C)

Speed-dependent locking/unlocking of the LL axle via EBS when driving forwards/reversing

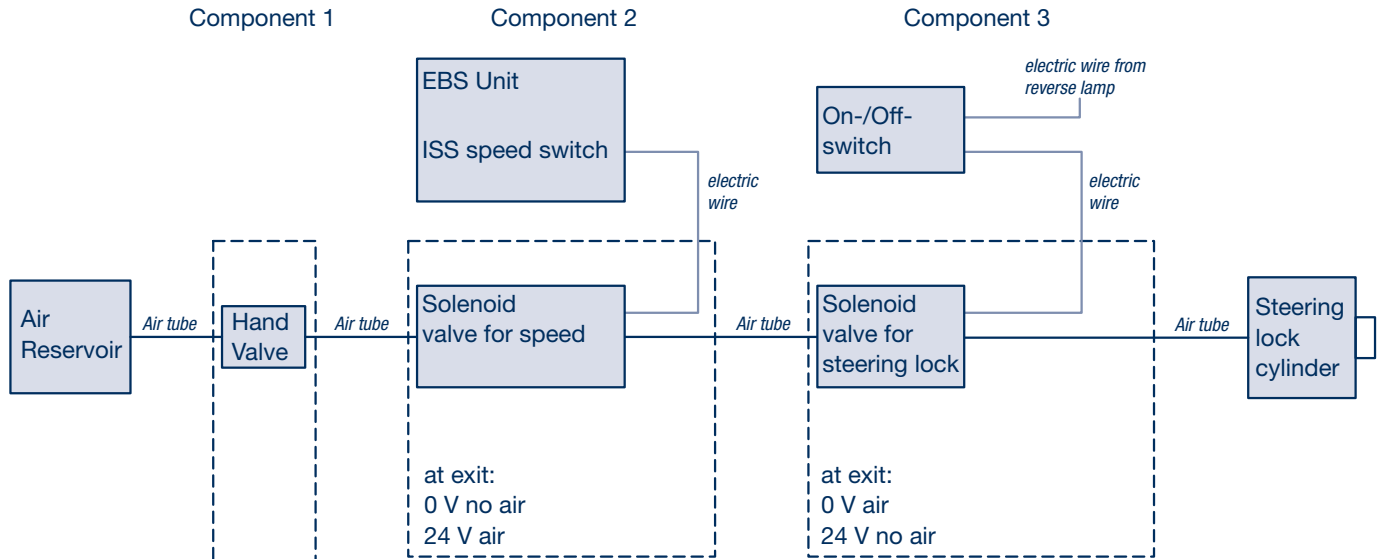

With the circuit diagram shown and all 3 components connected in series, it is possible to:

- Permanently lock the steering axle with a manually operated valve.
- Lock the steering axle based on the speed travelled using the EBS brake system when driving forwards.
- The steering axle can be locked using an electrical selector switch and by switching on the reversing lights.

Depending on the combination of components, the following options are available:

- Component 1 only: The steering axle can only be locked using a hand valve.
- Component 3 only: The steering axle can be locked using a selector switch and by switching on the reversing lights.
- Components 1 and 3: The steering axle can be locked using either a hand valve or an electrical lock by way of a selector switch and by switching on the reversing lights

With all 3 options, it is possible to add component 2 to speed-dependent locking via the EBS system when driving forwards.

3 Installation

3.7 Radio receiver

3.7 Radio receiver

The radio receiver must be attached to the chassis in the vicinity of the ARC control and hydraulic unit by means of three screws. The "CTC" cable of the radio receiver must be connected to the CN2 wiring loom of the electronic control unit via the 6-pin SuperSeal plug.

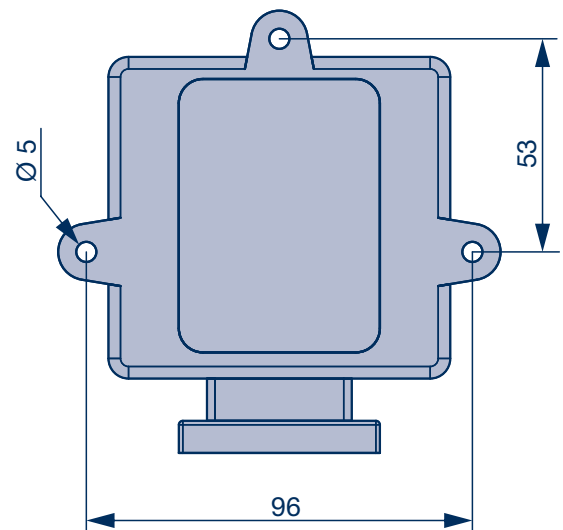
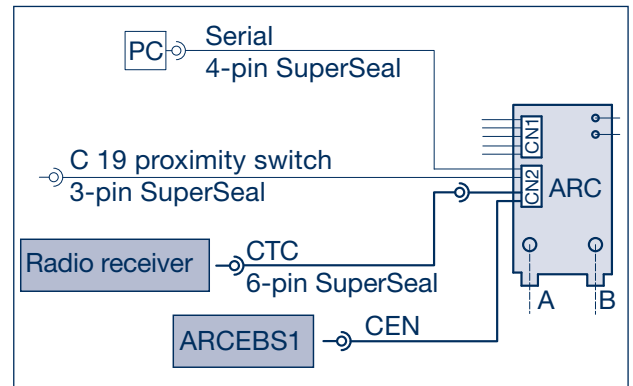

Installation 3

Wiring diagram 3.8

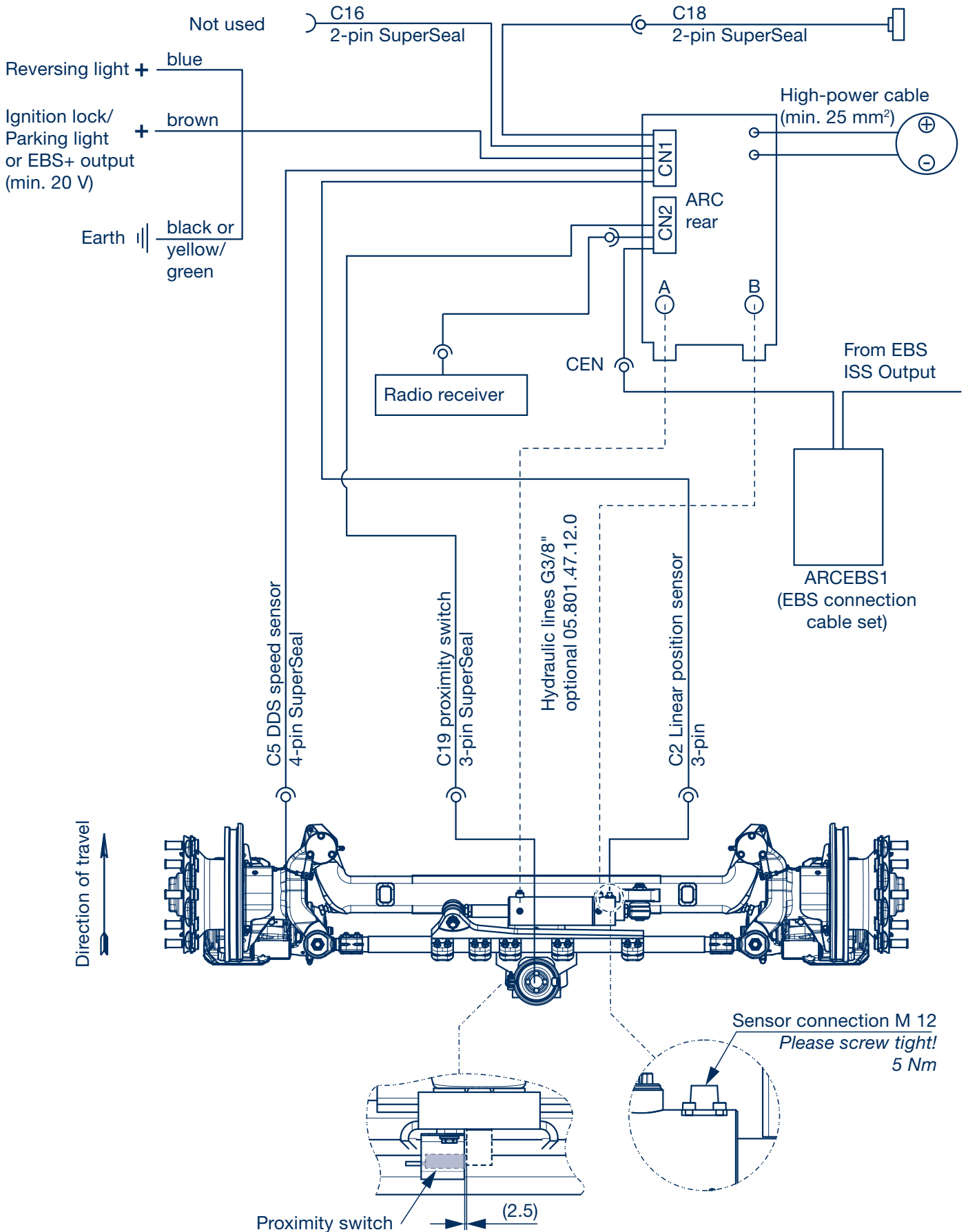

3 Installation

3.9 Recommendations for preparing the high-power supply for the truck

The high-power supply for the truck is not included in the BPW scope of supply. BPW offers, as an option, a two-pin line with plug only for the trailer. The high-power cable connects the control and hydraulic unit to the batteries of the vehicle. The full arrangement for the general case is as follows.

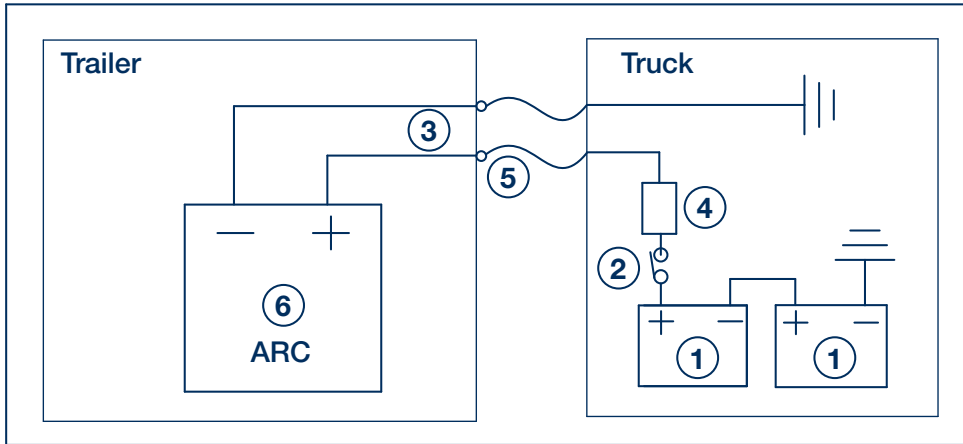

Example 1: Chassis negative, ignition lock positive

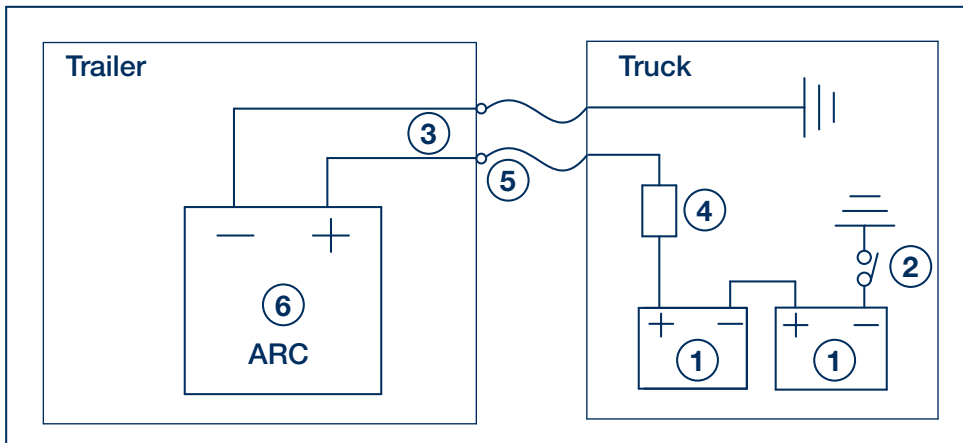

Example 2: Chassis negative, ignition lock negative

- ① 2x 12 V batteries
- ② Ignition lock
- ③ Power cable (2 x one-pin 25 mm) of the length required to connect the system to the batteries and the to 2 x 8 mm eyelets
- ④ 125 A fuse
- ⑤ Power connector plug on the drawbar trailer
- ⑥ BPW ARC control and hydraulic unit



Installation and repair guide!

The connection is dependent on the truck.

Remember to disconnect the power supply to the battery before making this connection.

Installation 3

Recommendations for preparing the high-power supply for the truck 3.9

With regard to the on-board electrical system of the truck, it should be noted that the electrical systems of certain truck types differ from those shown in the illustration above:

- If the electrical system of the truck does not have a negative chassis, connect the negative cable straight to the negative terminal on the batteries.
- If the vehicle's main battery switch is located at the negative terminal, the chassis is negatively connected and the positive terminal is on the positive terminal of the batteries, do not connect the negative terminal to the negative terminal on the batteries.

Make sure that the power cables are correctly protected on the towing vehicle by a sheath, in order to connect them to the NATO plug. The cables must be positioned in such a manner that they are long enough to prevent the plug from becoming overloaded, even during the tightest manoeuvres.

We recommend the use of extensible spiral cables with a minimum cross section of 25 mm². Otherwise, use standard cables with a minimum cross section of 25 mm², suitably attached to the other lines that are connected to the tractor unit.

The cables must be connected to the positive terminal of the vehicle batteries via a 125 A fuse so that the steering system is not supplied with power when the battery master switch is switched off.



Installation and repair guide!

All power cables must have a minimum cross-section of 25 mm².

For cable lengths over 10 m, the minimum cross-section must be 35 mm².

Consider the need for additional cover protection in the passageways that are exposed to the risk of abrasion.

If the semi-trailer is to be pulled by several trucks, it makes sense to equip the semi-trailer with an extendable spiral cable and all trucks with a fixed socket, which is supplied with power via a 125-A fuse on the positive terminal.

4 Commissioning

4.1 Oil fill



Installation and repair guide!

Only one power source may be used during commissioning!

The commissioning procedure comprises the following steps:

1. Filling oil
2. Checking the function lights in the electronic control unit
3. Configuration selection
4. Air-bleeding
5. Setting the maximum steering angles



Installation and repair guide!

Use only new and clean type VG15 mineral oil for the filling process (approx. 8 litres).

If the solenoid valve is in the way during the oil fill process, it has to be unscrewed. When the process is completed, the solenoid valve must be re-mounted.

Fill the oil tank with 8 litres of viscosity class VG15 mineral oil. Use only new and clean oil to fill a funnel.



Installation and repair guide!

After air-bleeding once the cylinder is full, the oil level in the tank drops. The normal oil level when the wheels and air-bleeding circuit are straight is approx. half the tank.



The hub cap for the oil fitting is located beneath the solenoid valve.

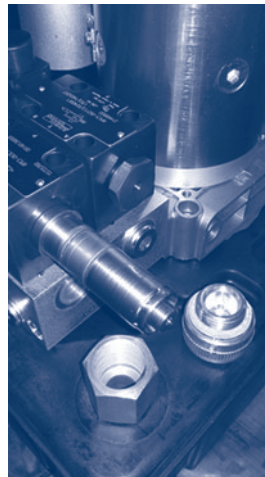

1. If necessary, dismount the magnet.
2. Open the hub cap
3. Add oil
4. If the magnet was dismounted: position the O-ring in the groove of the magnet and then attach the magnet in its position on the bolt.

Checking the installation

Check the following points prior to commissioning the vehicle:

- Make sure that all connections are made
- Check whether all cables are correctly connected, paying particular attention to the output of the electronic unit and to the axles. Make sure that the cables are not kinked or damaged in the axle suspension or steering systems
- Make sure that the hydraulic hoses are firmly located and not kinked or damaged by the movement of the axle suspension or steering systems
- Check whether the oil level is approx. 3/4 of the tank level.
- Make sure that all sensors are firmly located in their supports.

Commissioning 4

Checking the function lights in the electronic control unit 4.2



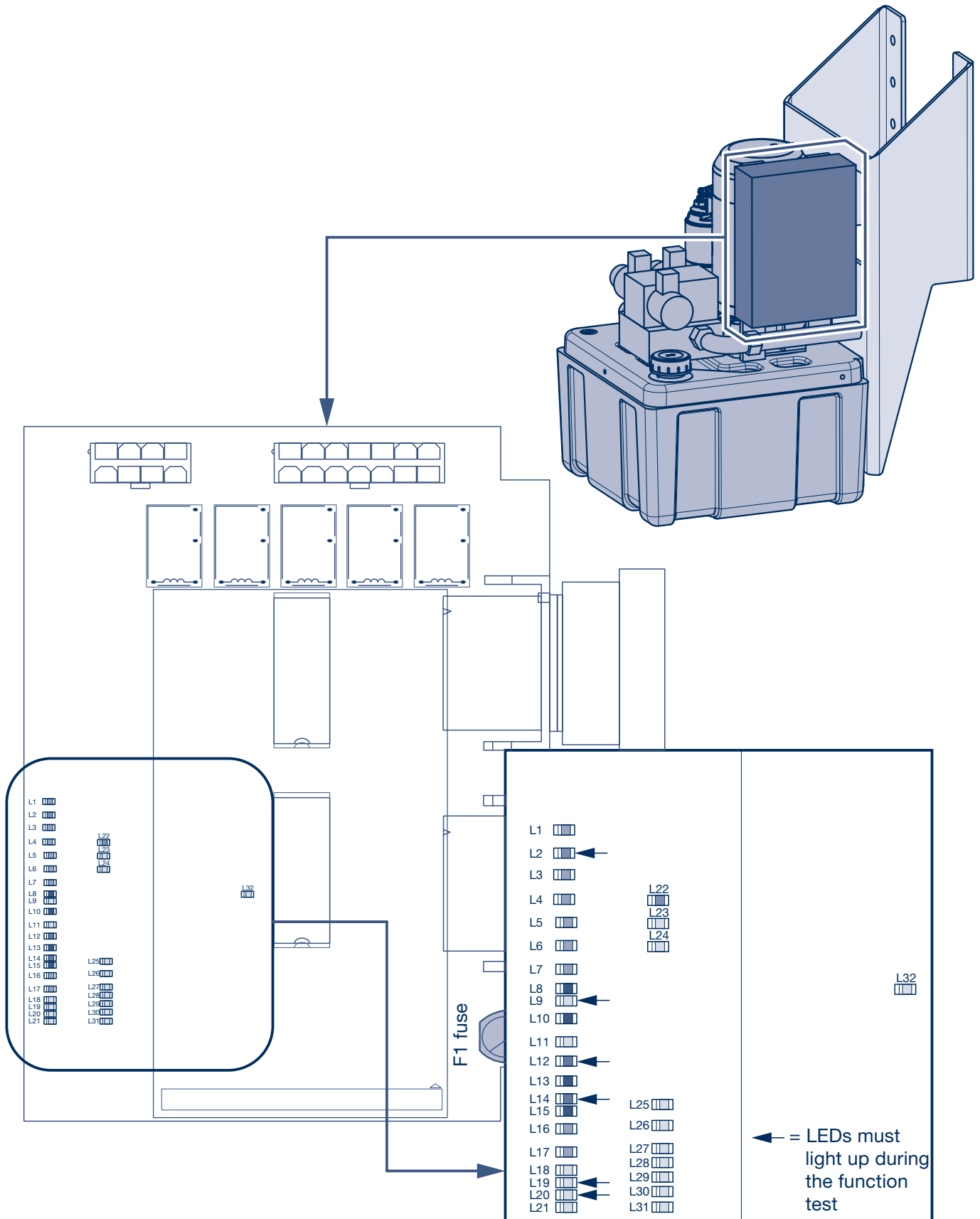

The figure below shows the position of the LEDs located on the circuit board in the control unit.



4 Commissioning

4.2 Checking the function lights in the electronic control unit

Electronic lines:

LED	Meaning	Connection	Comment
L2	 Positive terminal reversing light	CN1 - C1 (blue)	Illuminates when the reversing lights are switched on.
L8	24 V negative terminal	Negative terminal high-power cable	Must not illuminate. If this does illuminate, 24 V negative terminal is not in place.
L10	Negative terminal reversing light	CN1 - C1 (black)	Must not illuminate. If this does illuminate, negative terminal reversing light is not in place.
L12	 Positive terminal (e.g.: parking light)	CN1 - C1 (brown)	Illuminates when the control unit is supplied with low power through the "C1 brown" cable.
L13	Warning lamp	CN1 - C18	Illuminates when the F1 fuse in the control box trips or an error code is generated in case of a system failure.
L14	 24 V positive terminal	Positive terminal high-power cable	Illuminates when the 24 V positive terminal is in place.
L18	DDS sensor channel 2	CN1 - C5	Flashes when the wheel is turned slowly.
L19	 Proximity switch for the lock unit	CN2 - C19	Illuminates when the axle is unlocked. Does not illuminate if the axle is locked.
L20	 Linear position sensor in the steering cylinder	C1 - C2	This is switched on with variable brightness depending on the axle steering angle.
L21	DDS sensor channel 1	CN1 - C5	Flashes when the wheel is turned slowly.
L22	EBS signal	CN2 – CEN – ARCEBS1 - EBS	It is on when the power supply from the NATO connector is present and when the enabling signal from the EBS system is present
L23	Steering axle lifted	CN1 - C16	If the steering axle is a lift axle, this LED illuminates when the axle is lifted.

Remote control

LED	Meaning	Connection	Comment
L27	Automatic mode switched via remote control	CN2 - CTC	Illuminates when function button 2 on the remote control is pressed.
L29	Manual control to the left	CN2 - CTC	Illuminates when function button 3 on the remote control is pressed.
L30	Manual mode switched via remote control	CN2 - CTC	Illuminates when function button 1 is pressed on the remote control. Does not illuminate when function button 2 on the remote control is pressed.
L31	Manual control to the right	CN2 - CTC	Illuminates when function button 4 on the remote control is pressed.

Internal diagnostics in the control and hydraulic unit

LED	Meaning	Connection	Comment
L1	Output - "blocking solenoid valve"	Internal	Light on when the "blocking solenoid valve" is activated.
L3	Output - "left solenoid valve"	Internal	Light on when the "left solenoid valve" is activated.
L4	Output - "right solenoid valve"	Internal	Light on when the "right solenoid valve" is activated.
L5	Output - "synchro solenoid valve"	Internal	Light on when the "synchro solenoid valve" is activated.
L6	Automatic reset of the steering axle into the straight position	-	Normally does not illuminate.
L7	Output- oil pump	Internal	Illuminates when the oil pump is activated.
L9	 Not used	Internal	Normally illuminates
L15	Thermal switch	Internal	Normally switched off - switches on temporary if the electric motor overheats.
L26	Blocking solenoid valve proximity switch	Internal	Light on when the blocking solenoid valve is activated (and also the sensor light). Light off when the blocking solenoid valve is deactivated (and also the sensor light).

 = LEDs must light up during the function test

Commissioning 4

Configuration selection 4.3

The configuration selection is required to provision the vehicle parameters for the control unit. The vehicle parameters for most vehicle types are preconfigured in 12 configuration files in the data memory. The appropriate configuration must be selected during the commissioning procedure.

The configuration can be carried out either with the BPW ARC app on a smartphone using a Bluetooth connection or with the aid of the remote control. Once the configuration process is completed, the remote control can be removed and used for other ARC control and hydraulic units (One-time investment).

The appropriate configuration file can be defined using tyre- and wheelbase parameters:

		Wheelbase parameter			
		"A"	"B"	"C"	"D"
Tyre parameter	"1"	Configuration file 1	Configuration file 2	Configuration file 3	Configuration file 4
	"2"	Configuration file 5	Configuration file 6	Configuration file 7	Configuration file 8
	"3"	Configuration file 9	Configuration file 10	Configuration file 11	Configuration file 12

The tyre parameter is dependent on the tyre diameter and the number of teeth in the exciter ring.

The wheelbase parameter is dependent on the number and arrangement of the axles and on the distances between the axles (the distances between the axles may be different).

The tyre parameters and the wheelbase parameters can be read from the tables below.

Example:

For a 3-axle trailer (rigid, rigid, LL), with wheelbases of 1310 – 1310, 385/65 R22.5" tyres and a 90-tooth exciter ring, configuration file 10 (tyre parameter "3" and wheelbase parameter "B") must be selected.

Comment

BPW LL axles for 9 t axle load (ECO Plus 3 wheel bearing) are generally equipped with a 90-tooth exciter ring.

BPW LL axles for 10 – 12 t axle load (ECO Plus wheel bearing) are equipped with an 80-tooth exciter ring for R 19.5" tyres and a 100-tooth exciter ring for R 22.5" tyres.

4 Commissioning

4.3 Configuration selection

Defining the tyre parameter

Tyre parameters 1, 2 or 3 can be read from the table below.

Tyre size	Tyre diameter (mm)	Number of teeth for exciter ring	Tyre parameters
17.5" tyre			
205/65 R 17.5	710	90	1
205/65 R 17.5	710	80	1
215/75 R 17.5	780	90	1
215/75 R 17.5	780	80	2
9.5 R 17.5	846	90	2
9.5 R 17.5	846	80	2
235/75 R 17.5	796	90	1
235/75 R 17.5	796	80	2
245/70 R 17.5	796	90	1
245/70 R 17.5	796	80	2
19.5" tyre			
255/60 R 19.5	805	90	1
255/60 R 19.5	805	80	2
265/70 R 19.5	866	90	2
265/70 R 19.5	866	80	2
265/55 R 19.5	783	90	1
265/55 R 19.5	783	80	2
285/70 R 19.5	892	90	2
285/70 R 19.5	892	80	2
425/55 R 19.5	980	90	2
425/55 R 19.5	980	80	3
445/45 R 19.5	906	90	2
445/45 R 19.5	906	80	2
445/65 R 19.5	1081	90	3
445/65 R 19.5	1081	80	3
22.5" tyre			
385/55 R 22.5	1002	90	2
385/55 R 22.5	1002	100	2
385/65 R 22.5	1068	90	3
385/65 R 22.5	1068	100	2
425/65 R 22.5	1130	90	3
425/65 R 22.5	1130	100	2
445/65 R 22.5	1154	90	3
445/65 R 22.5	1154	100	2
275/70 R 22.5	966	90	2
275/70 R 22.5	966	100	2
11 R 22.5	1050	90	2
11 R 22.5	1050	100	2
12 R 22.5	1082	90	3
12 R 22.5	1082	100	2
315/80 R 22.5	1091	90	3
315/80 R 22.5	1091	100	2

Commissioning 4

Configuration selection 4.3

Defining the wheelbase parameter

Wheelbase "A", "B", "C" or "D" can be read from the table below.

Number of axles	Axle arrangement	Trailer wheelbases				Wheelbase parameter
		Wb1	Wb2	Wb3	Wb4	
2	1 x Rigid 1 x LL	1310	-	-	-	A
		1810	-	-	-	B
		2020	-	-	-	B
3	2 x Rigid 1 x LL	1310	1310	-	-	B
		1410	1410	-	-	B
		1170	1500	-	-	B
		1310	1810	-	-	C
		1310	2020	-	-	C
		1810	1310	-	-	B
		1810	1810	-	-	C
		1810	2020	-	-	C
	2020	2020	-	-	C	
	1 x Turntable 1 x Rigid 1 x LL	-	1310	-	-	A
		-	1810	-	-	B
-		2020	-	-	B	
4	3 x Rigid 1 x LL	1310	1310	1310	-	C
		1310	1310	1310	-	C
	1310	1810	1810	-	C	
	1310	2020	2020	-	D	
5	4 x Rigid 1 x LL	1310	1310	1310	1310	D
		-	-	1310	1310	B
	-	-	1310	1810	C	
	-	-	1810	1810	C	

Explanation of wheelbases:

- Wheelbase 1: Distance between 1th and 2th trailer axle
- Wheelbase 2: Distance between 2th and 3th trailer axle
- Wheelbase 3: Distance between 3th and 4th trailer axle
- Wheelbase 4: Distance between 4th and 5th trailer axle

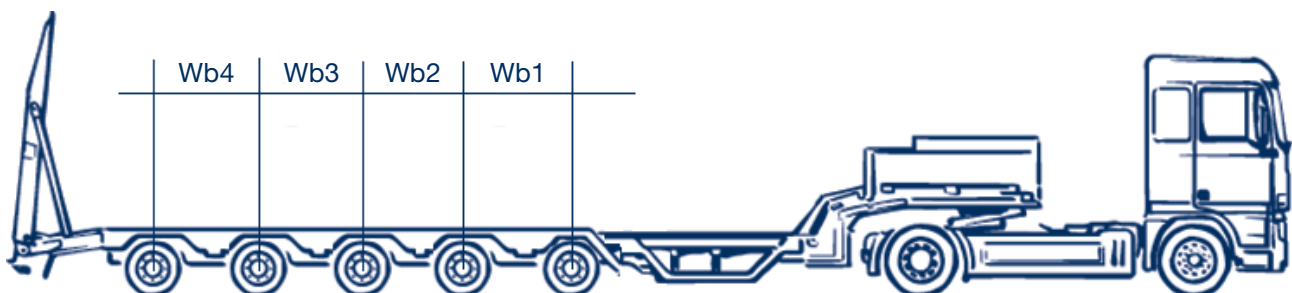

4 Commissioning

4.3 Configuration selection

The configuration can be selected either with the BPW ARC app on a smartphone using a Bluetooth connection or with the aid of the remote control. One remote control can be used for several ARC control and hydraulic units.

4.3.1 Selecting a configuration with the BPW ARC app

1. Log in as POWERUSER or more privileged user (service).
2. Go to the "Settings" tab and press "LOAD" under the configuration.
3. You can select the correct configuration number from the list.
4. Select the correct configuration number (from 1 to 12) for your product from the configuration selection table on page 31.

You will find a detailed explanation in the "BPW ARC App Manual".

4.3.2 Selecting a configuration using the remote control

1. Select a configuration to suit you (1...12) from the table on page 31.
2. Switch on the system.
Switch-on = voltage on the C1 cable, brown
3. Wait 3 seconds until the warning lamp flashes once.
4. Now press the "Start" button and "Button 2" immediately afterwards. If "Button 2" was not pressed in time, the warning lamp will start to flash slowly and quickly. If this happens, switch off the system completely, switch it back on and repeat the process from point 2.
5. The system is in configuration mode.
6. The warning lamp starts to flash as follows: 1x flash, 2 second pause, 2x flash, 2 second pause, 3x flash, 2 second pause up to 12x flashes, 2 second pause and the process then starts again with the first 1x flash.
7. Press "Button 4" during the pause after the desired number of flashes.
8. Once the configuration has been selected, the warning lamp flashes slowly once (2 seconds), and then repeats the selected number of flashes.
9. The warning lamp then flashes for three seconds. If the number is OK, press "Button 3" within these 3 seconds to save the configuration. The configuration has been confirmed, the air-bleeding procedure can start.
10. If the configuration is not confirmed, the warning lamp will start to flash slowly and quickly. If this happens, switch off the system completely, switch it back on and repeat the process from point 2.

If you want to check the ordinal number of the selected configuration at a later time, follow points 2 to 4.



Installation and repair guide!

Please make sure the configuration is correct. Once selected and confirmed, an incorrect configuration cannot be corrected via the remote control. In this case, get in touch with BPW.

Commissioning 4

Air-bleeding 4.4

4.4 Air-bleeding

Bleeding can be carried out with the BPW ARC app using a Bluetooth connection or with the aid of the remote control. One remote control can be used for several ARC control and hydraulic units.

4.4.1 Bleeding using the BPW ARC app

1. Make sure that the control unit is supplied with power (ignition lock must be switched on and cable CN1 connected).
2. Engage reverse gear and ensure that the axle is unlocked.
3. In the app, go to the "Command" tab and then to the "Manual Commands" tab. There you will find the control commands "Left" and "Right".
 With these "function buttons 3 and 4" you control the steering 5x to the left and 5x to the right to the end of the cylinder stroke. If the cylinder has not been mounted with the connections facing upwards and is equipped with drain plugs, bleed the air out of them.
4. After bleeding, check that the steering responds to the steering commands without delay. If it does not, carry out step 3 again.
5. When commissioning is complete, all alarms must be reset.
 To do this, click on the "Reset alarm messages" button in the "Alarms" tab.
6. Once the commissioning procedure has been completed, the system must be restarted.

4.4.2 Bleeding using the remote control

1. Switch on the ARC control and hydraulic unit.
 Switch on = voltage on the C1 cable, brown
 (If already switched on, turn it off and back on again).
2. Press the "Start button" on the radio remote control as soon as the warning lamp flashes for the first time.
3. If the remote control is switched on, press "Button 1" for at least 3 seconds and check whether the LED L30 on the conductor plate stays illuminated once the button is released.
4. Although the system is in bleed mode, the air-bleeding procedure cannot start until reverse gear is engaged. The warning lamp flashes slowly (2 second pauses between flashes).
5. Activate reverse gear.
6. The system is in bleed mode, the warning lamp flashes quickly.
7. Press "Button 3" or "Button 4" once. The warning light extinguishes.
8. Use "Function buttons 3 and 4" to control the steering 5x to the left and 5x to the right through to the end of the stroke. If the cylinder was not mounted with the connections facing upwards and is fitted with drain plugs, bleed air to escape from them.
9. Once the air-bleeding procedure has completed successfully, switch the system off and on again.



Installation and repair guide!

To bleed the steering cylinder, use the air-bleeding screws (optional from BPW) and hoses to collect the oil in a closed container.

At the end of the procedure, check the oil level in the tank, which should be around 3/4 full, the axle being located in the centre.



Warning:

The hydraulic oil is under pressure. Wear safety goggles for all air-bleeding procedures. Use air-bleeding screws (e.g. Minimes) and collect the oil in a closed container.



Installation and repair guide!

Carefully tighten the air-bleeding screws by hand to prevent damage to the thread.

4 Commissioning

4.5 Setting the maximum steering angles

4.5 Setting the maximum steering angles after the air-bleeding procedure

After the air-bleeding procedure, the maximum steering angles of the steering axles have to be set. During this process, the system (software) automatically saves the end position of the steering axle.

In automatic mode, the system saves the maximum steering angles of the axle and uses them as limit values for the steering control.

Once these limit values have been saved, the system will stop the steering operation before they are reached and the cylinder will not press the axle against the steering lock limiter.

To note the limit values, reverse at a speed of over 3 km/h and make a sharp turn so that the axle is monitored at the end of its path. This position is saved once you have pressed the steering lock limiter for a few seconds. Make a turn in the opposite direction to note the other limit.

Note: The system only saves the end positions when driving in automatic mode (not in manual mode) and only when a speed higher than 3 km/h is reached.



Installation and repair guide!

Check the orientation of the vehicle when driving straight ahead. The wheels must be straight.

The steering axle must move without instability/delay. If a delay or unstable movement occurs, there is air in the system.

Make sure the power cable has sufficient clearance between the truck and the semi-trailer, especially at maximum kink angle.



Warning:

The BPW ARC auxiliary steering has an effect on the driving characteristics when reversing. Always manoeuvre carefully.

Do not carry out reversing manoeuvres faster than 10 km/h with BPW ARC auxiliary steering.

Maintenance 5

Diagnostics 5.1

The system has an expanded warning management function.

- 1) Alarms are logged in the system memory.
- 2) The most common alarms are displayed on the warning lamp installed in the vehicle and additionally on the circuit board via LED 13. The alarms can be viewed on the BPW ARC app. Use the BPW ARC App Manual.
- 3) The function status of the main features is displayed by the circuit board LEDs, and these become visible through the transparent plastic cover as soon as the black plastic cover is removed.

During normal operation, the electronic system unit checks whether the system is functioning correctly. Any problem detected during a check is saved in the permanent section of the mainboard memory. Under certain circumstances, the warning light is also switched on (flashing cancelled).

To help the user make a diagnosis, the warning light flashes after an alarm is detected when the error warning lamp is switched on, with the number assigned to the warning saved in the table below. This occurs the next time the main board is powered up.

The lamp flashes slightly quicker at first.

It is possible to log false alarms concerning electronic peaks in vehicle transitions.

Warning code = Number of flashes ⁽²⁾	Warning	Warning lamp ⁽¹⁾
1	Internal monitoring data missing on the controller	Illuminates
2	Internal monitoring data on the controller incorrect	Illuminates
3	Error receiving data during the auto test	Illuminates
4	Self-test of the solenoid valve sensor failed	Illuminates
5	Auto test failed - Relay RL4	Illuminates
6	Auto test failed - Relay RL2	Illuminates
7	No signal from the BPW DDS sensor	Illuminates
8	Moving forward at high speed with reverse gear engaged	Illuminates
9	File not completely loaded into the memory	Illuminates
10	Thermal cutout	Does not illuminate
11	Linear position sensor outside the measuring range	Illuminates
12	Calibration error	Illuminates
13	Auto test failed - Relay RL3	Illuminates
14	Self-test of solenoid valve failed	Illuminates
15	Internal data receive timeout	Illuminates
16	Stop in case of weak battery	Does not illuminate
17	Irregular signal from BPW DDS sensor	Illuminates
18	Steering command failed	Illuminates
19	Electronic control unit not calibrated or EBS ISS signal present at high speed in forward gear	Illuminates

⁽¹⁾ Warning lamp illuminates continuously if the warning is marked

⁽²⁾ Warning lamp flashes next time the system is switched on

5 Maintenance

5.2 Diagnostic warnings

Warning code 1 - Internal control data missing on the controller	
Warning code 2 - Internal monitoring data on the controller incorrect	
<p>Meaning 0.5 seconds after a query from one of the two micro-processors, the second processor receives no response 3x (Code 1) or an incorrect response (Code 2).</p> <p>Execution The check is run every second when the control unit is being supplied with power.</p> <p>Consequences If this warning occurs, the axle returns freely to the self-steering condition. Reversing is not possible without the axle lock.</p>	
Possible cause	Possible corrective measures
Microprocessors incorrectly positioned in the base	Contact BPW
One of the microprocessors fails	Contact BPW
Error on the mainboard for the micro	Contact BPW
<p>Warning lamp The warning lamp illuminates as soon as the alarm is tripped and stays on until the electronic system is switched off.</p>	

Warning code 3 - Error receiving data during the auto test	
<p>Meaning 0.5 seconds after an auto test query by microprocessor 1, microprocessor 1 receives no response three times.</p> <p>Execution The check is run each time the electronic system is switched on and/or during every reversing manoeuvre if the vehicle moves (rolls) forwards in reverse gear.</p> <p>Consequences If this warning occurs, the axle returns freely to the self-steering condition. Reversing is not possible without the axle lock.</p>	
Possible cause	Possible corrective measures
Microprocessors incorrectly positioned in the base	Contact BPW
One of the microprocessors fails	Contact BPW
Error on the mainboard for the micro	Contact BPW
<p>Warning lamp The warning lamp illuminates as soon as the alarm is tripped and stays on until the electronic system is switched off.</p>	

Maintenance 5

Diagnostic warnings 5.2

Warning code 4 - Self-test of solenoid valve failed	
<p>Meaning During the check, the command (solenoid valve with 2 positions) was not confirmed by the control proximity sensor (sensor error or incorrect valve movement).</p>	
<p>Execution The check is run whenever reverse gear is engaged and the vehicle starts to move backwards after the forward manoeuvre.</p>	
<p>Consequences If this warning occurs, the axle returns freely to the self-steering condition. Reversing is not possible without the axle lock.</p>	
<p>Possible cause Solenoid shut-off valve proximity sensor incorrectly set.</p>	
Possible primary cause	Possible corrective measures
Negative terminal not connected (LED 10 switched on)	LED 10 must be switched off; if it is switched on, check whether the black cable (C1 cable) is connected to the negative terminal on the chassis.
No power supply to the blocking solenoid valve (2-position valve) from the mainboard.	Contact BPW
The power supply from the mainboard is in order, but the solenoid valve is not receiving power.	Contact BPW
The blocking solenoid valve (2-position valve) is correctly supplied with power, but the valve does not move.	Valve is locked. Contact BPW.
The blocking solenoid valve (2-position valve) is locked, but the proximity sensor does not read the position.	Check the proximity sensor in the solenoid valve. Dismount the sensor and try to close it with the piece of metal. If the LED of the internal sensor illuminates (LED 26), this could be sufficient to reset the sensor. Contact BPW.
<p>Warning lamp The warning lamp illuminates as soon as the alarm is tripped and stays on until the electronic system is switched off.</p>	

5 Maintenance

5.2 Diagnostic warnings

Warning code 5 - Auto test failed - Relay RL4	
<p>Meaning Error with the internal relay that switches off the control voltage to the pump and to the solenoid valves if reverse gear is not active. On the basis of an internal test procedure, the control measured an interval of an incorrect voltage signal, which may be caused by incorrect functioning of the internal relay.</p>	
<p>Execution The check is run each time the electronic system is switched on and if the reversing light does not illuminate.</p>	
<p>Consequences If this warning occurs, the axle returns freely to the self-steering condition. Reversing is not possible without the axle lock.</p>	
<p>Possible cause The warning may illuminate due to a permanent problem in the oil pump relay.</p>	
Possible primary cause	Possible corrective measures
Relay RL4 on the mainboard is locked in the closed position.	Mainboard replacement. Contact BPW.
Relay RL4 is not locked, but something in the pump's electric circuit is not working.	Contact BPW.
<p>Warning lamp The warning lamp illuminates as soon as the alarm is tripped and stays on until the electronic system is switched off.</p>	

Warning code 6 - Auto test failed - Relay RL2	
<p>Meaning Error with the internal relay that switches off the control voltage to the pump and to the solenoid valves if reverse gear is not active. On the basis of an internal test procedure, the control measured an interval of an incorrect voltage signal, which may be caused by incorrect functioning of the internal relay.</p>	
<p>Execution The check is run each time the electronic system is switched on and if the reversing light does not illuminate.</p>	
<p>Consequences If this warning occurs, the axle returns freely to the self-steering condition. Reversing is not possible without the axle lock.</p>	
<p>Possible cause The warning may illuminate due to a permanent problem in the oil pump relay.</p>	
Possible primary cause	Possible corrective measures
Relay RL2 on the mainboard is locked in the closed position.	Mainboard replacement. Contact BPW.
<p>Warning lamp The warning lamp illuminates as soon as the alarm is tripped and stays on until the electronic system is switched off.</p>	

Maintenance 5

Diagnostic warnings 5.2

Warning code 7 - No signal from the BPW DDS sensor	
<p>Meaning During the self-diagnosis, the ECU did not detect the signal from the BPW DDS sensor.</p> <p>Execution The check is run each time the electronic system is switched on and if the reversing light does not illuminate.</p> <p>Consequences If this warning occurs, the axle returns freely to the self-steering condition. Reversing is not possible without the axle lock.</p>	
Possible cause	Possible corrective measures
<p>The DDS sensor is faulty.</p> <p>The DDS sensor is far away from the exciter ring.</p> <p>The DDS sensor is damaged.</p>	<p>Check the sensor position on the left wheel and/or the sensor connections</p> <p>The sensor position is correct if both LEDs, L18 and L21, flash while the wheel equipped with a sensor turns slowly</p>
<p>Warning lamp The warning lamp illuminates as soon as the alarm is tripped and stays on until the electronic system is switched off.</p>	

Warning code 8 - Moving forward at high speed with reverse gear engaged	
<p>Meaning This warning is activated if the system detects a speed of over 15 km/h for more than 3 seconds and reverse gear is engaged.</p> <p>Execution When the vehicle is travelling forwards.</p> <p>Consequences If this warning occurs, the axle returns freely to the self-steering condition. Reversing is not possible without the axle lock.</p> <p>Possible cause The check is made on all working vehicles (both forwards and backwards).</p>	
Possible primary cause	Possible corrective measures
Reversing light voltage continuously present	Look for the electric circuit fault
Vehicle descends a hill with reverse gear engaged (and clutch pressure)	Prevent this possibility. Misuse!
<p>Warning lamp The warning lamp illuminates as soon as the alarm is tripped and stays on until the electronic system is switched off.</p>	

5 Maintenance

5.2 Diagnostic warnings

Warning code 9 - File not completely loaded into the memory	
<p>Meaning This warning is output if the memory status is not correctly displayed when the ECU is started.</p>	
<p>Execution The check is run each time the electronic system is switched on and if the reversing light does not illuminate.</p>	
<p>Consequences If this warning occurs, the axle returns freely to the self-steering condition. Reversing is not possible without the axle lock.</p>	
<p>Possible cause The check is made on all working vehicles (both forwards and backwards).</p>	
Possible primary cause	Possible corrective measures
A memory write error occurred or memory writing was started, and stopped before it was completed.	Contact BPW
<p>Warning lamp The warning lamp illuminates as soon as the alarm is tripped and stays on until the electronic system is switched off.</p>	

Maintenance 5

Diagnostic warnings 5.2

Warning code 10 - Thermal cutout	
<p>Meaning This warning is displayed if the mainboard detects the opening of the thermal protective switch on the pump motor. This switch is normally closed and is activated only when the motor exceeds a specific temperature threshold. Once the temperature drops, the system returns to the normal condition.</p> <p>Execution The check is run each time the electronic system is switched on and if the reversing light does not illuminate.</p> <p>Consequences When reverse gear is engaged, the axle is moved to a centre position and the pump motor is switched off. The axle is held in this position, with a brief pump restart for the time required for any realignment. If the thermal switch closes again spontaneously, the system will resume normal operation without the control unit having to be switching off and back on again. Manual control cannot be used.</p> <p>Possible cause Motor has heated up above a specific temperature threshold. Problem with the electrical connections of the thermal switch.</p>	
Possible primary cause	Possible corrective measures
The thermal switch opens due to an overtemperature. The motor is hot.	Once the temperature has reduced, the switch closes automatically and the system continues to operate
The thermal switch is defective and remains open even when the motor is cold.	Measure the voltage between the thermal switch plug (single cable coming from the pump motor, plug C12) and the vehicle negative. If the thermal switch is opened, the voltage value with a voltage supply circuit board is close to 24 V, otherwise it is zero. Make sure that the second wire of the thermal switch is connected to the vehicle negative.
The thermal switch is working, but there is a problem with the electric circuit	Contact BPW
<p>Warning lamp The warning lamp does not illuminate with this error.</p>	

5 Maintenance

5.2 Diagnostic warnings

Warning code 11 - Displacement sensor outside the measurement range	
<p>Meaning During a diagnostic procedure, the electronic control unit detects that the signal coming from the steering sensor is outside the expected range of 0.5–4.5 volt.</p>	
<p>Execution The check is run when the control unit is switched on, during the steering command, and also in forward gear at high speed</p>	
<p>Consequences If this warning occurs, the axle returns freely to the self-steering condition. Reversing is not possible without the axle lock.</p>	
Possible cause	Possible corrective measures
<p>The steering sensor is faulty The steering sensor cable is faulty</p>	<p>Contact BPW. If the steering sensor signal is correct, the L20 LED changes its brightness by changing the steering position of the axle</p>
<p>Warning lamp The warning lamp illuminates as soon as the alarm is tripped and stays on until the electronic system is switched off.</p>	

Warning code 12 - Calibration error	
<p>Meaning During a diagnostic procedure, the electronic control unit detects a malfunction or a calibration error of an internal component.</p>	
<p>Execution The check is run when the control unit is switched on, during the steering command, and also in forward gear at high speed.</p>	
<p>Consequences If this warning occurs, the axle returns freely to the self-steering condition. Reversing is not possible without the axle lock.</p>	
<p>Possible cause In the electronic control unit, the rear conductor plate was replaced without a calibration procedure having been run.</p>	
Possible primary cause	Possible corrective measures
<p>An internal component of the electronic control unit is faulty or has changed its operating parameters</p>	<p>Contact BPW.</p>
<p>Warning lamp The warning lamp illuminates as soon as the alarm is tripped and stays on until the electronic system is switched off.</p>	

Maintenance 5

Diagnostic warnings 5.2

Warning code 13 - Auto test failed - Relay RL3

Meaning

Error with the internal relay that switches the control voltage to the pump and to the solenoid valves when reverse gear is not active. On the basis of an internal test procedure, the control measured the interval of an incorrect voltage signal, which may be caused by incorrect functioning of the internal relay.

Execution

The check is run when reverse gear is activated and disengaged and each time the vehicle moves forward with the reversing light on

Consequences

If this warning occurs, the axle returns freely to the self-steering condition. Reversing is not possible without the axle lock.

Possible cause

The warning may illuminate due to a permanent problem in the oil pump relay.

Possible primary cause

Relay RL3 on the mainboard is locked in the closed position.

Possible corrective measures

Mainboard replacement. Contact BPW.

Warning lamp

The warning lamp illuminates as soon as the alarm is tripped and stays on until the electronic system is switched off.

5 Maintenance

5.2 Diagnostic warnings

Warning code 14 - Self-test of solenoid valve failed	
<p>Meaning This alarm is tripped during a diagnostic procedure if the control unit detects that the signal of the blocking solenoid valve is closed (a signal from the open solenoid valve is expected).</p>	
<p>Execution The check is run when reverse gear is activated and disengaged and each time the vehicle moves forward with the reversing light on</p>	
<p>Consequences When the alarm is confirmed, a procedure that permits quick realignment of the axle is activated. As soon as the central position is reached, the axle is blocked there. However, due to the oil leak permitted by the hydraulic unit, it is possible to steer very slowly (self-steering effect). In this situation, no commands are issued to the axle. Under these conditions, only a very small number of reversing manoeuvres can be executed without mechanical blocking.</p>	
Possible cause	Possible corrective measures
<p>The blocking solenoid valve (2-position valve) is locked. This situation could be caused by a dirty hydraulic circuit and might therefore be unpredictable.</p>	<p>The movements of the axle are very slow, even when reverse gear is deactivated. The LED on the sensors illuminates at all times, as does LED 26 on the mainboard. Replace the blocking solenoid valve (red) on the main unit and check the cause of the valve blocking (dirty?).</p>
<p>The blocking solenoid valve (2-position valve) is not locked. The proximity sensor is incorrectly set or faulty.</p>	<p>The axle is damped only slightly during forward steering movements. Remove the proximity sensor from the solenoid valve and check whether it is functioning correctly (the internal yellow LED illuminates if a piece of metal is located in the vicinity). Make sure that LED 26 in the electronic control unit illuminates when the sensor detects the metal and switches off when the sensor is removed from the metal. If the LED illuminates continuously, continue with the next step to check whether the error is with the sensor or other parts.</p>
<p>The solenoid valve is not blocked and the sensor is functioning, but the mainboard does not read its signal correctly.</p>	<p>If the sensor is functioning, the solenoid valve is not blocked and is opened, LED 26 on the mainboard (or the voltage remains at around 24 V), disconnect sensor plug C15 and check that the LED switches off (or the voltage drops to zero). If it remains switched on after the connector is isolated (or if the voltage continues to be 24 V), there is a problem with the card or the wiring.</p>
<p>Warning lamp The warning lamp illuminates as soon as the alarm is tripped and stays on until the electronic system is switched off.</p>	

Maintenance 5

Diagnostic warnings 5.2

Warning code 15 - Internal data receive timeout

Meaning

This alarm is detected by microprocessor 1 if, during a data exchange procedure with the second microprocessor, it receives no response from this microprocessor 3x within a specified time.

Execution

This check is run when the circuit board is switched on and every reverse gear is switched on and off, and also during data exchange procedures between microprocessors, which can occur in reverse gear or while the vehicle is moving straight ahead. Speed above 36 km/h.

Consequences

If this warning occurs, the axle returns freely to the self-steering condition. Reversing is not possible without the axle lock.

Possible cause

The warning may illuminate due to a permanent problem in the oil pump relay.

Possible primary cause	Possible corrective measures
Microprocessors incorrectly positioned in the base	Contact BPW
One of the microprocessors fails	Contact BPW
Error on the mainboard for the micro	Contact BPW

Warning lamp

The warning lamp illuminates as soon as the alarm is tripped and stays on until the electronic system is switched off.

5 Maintenance

5.2 Diagnostic warnings

Warning code 16 - Stop in case of weak battery	
<p>Meaning This alarm is confirmed if, while a diagnostic procedure is being run, the control unit detects that the supply voltage to the electric circuit is not sufficient to supply the system in a proper manner. The alarm is detected in particular when the pump is switched on. In a situation in which no movement is controlled, the voltage on the electric circuit is less than 19.5 V.</p> <p>Execution The check is run when reverse gear is engaged and during reversing manoeuvres.</p> <p>Consequences The axle is controlled to and held in a central position, also with brief re-ignitions of the pump to restore the central position if necessary.</p> <p>Possible cause The warning may illuminate due to a permanent problem in the oil pump relay.</p>	
Possible primary cause	Possible corrective measures
Battery failure	Replace the batteries
Pump requires too much current	When the pump is switched on, the current in the power cable must be below 35 A. In case of a higher current, please check: <ol style="list-style-type: none"> 1) Motor pump 2) Pump 3) Solenoid control valves block
Excessive voltage drop in the power cable	Make sure, when the pump is running, that the current supply in the power pack is lower than the battery start voltage (for example: voltage drop greater than 2.5 V), and check for possible causes: <p>Connector between truck and drawbar trailer oxidised, insufficient cable section, loose terminals.</p> <p>Measure the positive battery power and the vehicle chassis.</p> <p>If the voltage drop is localised at one point, the heat development is sensitive. Watch out for fire and/or skin burns</p>
The mainboard measuring circuit is not yet calibrated	Mainboard replacement. Contact BPW.
<p>Warning lamp The warning lamp does not illuminate with this error.</p>	

Maintenance 5

Diagnostic warnings 5.2

Warning code 17 - Irregular signal from the BPW DDS sensor	
<p>Meaning This alarm is tripped if, during a diagnostic procedure, the control unit detects that the second sensor channel in the BPW DDS sensor is not switched over, while channel 1 is switched over.</p> <p>Execution The check is run while the vehicle is moving.</p> <p>Consequences If this warning occurs, the axle returns freely to the self-steering condition. Reversing is not possible without the axle lock.</p> <p>Possible cause The warning may illuminate due to a permanent problem in the oil pump relay.</p>	
Possible cause	Possible corrective measures
<p>The DDS sensor is faulty.</p> <p>The DDS sensor is far away from the exciter ring.</p> <p>The DDS sensor is damaged.</p>	<p>Check the sensor position on the left wheel and/or sensor connections.</p> <p>The sensor position is correct if both LEDs, L18 and L21, flash while the wheel equipped with a sensor turns slowly</p>
<p>Warning lamp The warning lamp illuminates as soon as the alarm is tripped and stays on until the electronic system is switched off.</p>	

5 Maintenance

5.2 Diagnostic warnings

Warning code 18 -Steering command failed	
<p>Meaning This alarm is tripped if the axle remains in the same position for longer than the maximum permissible time (approx. 2 seconds) while a controlled steering movement is being executed.</p> <p>Execution The check is run while the vehicle is moving.</p> <p>Consequences If this warning occurs, the axle returns freely to the self-steering condition. Reversing is not possible without the axle lock.</p> <p>Possible cause The cylinder is unable to apply the required steering force with the hydraulic system.</p>	
Possible primary cause	Possible corrective measures
<p>Problem of any kind in the hydraulic system if a steering command does not generate an axle movement. A delayed or discontinuous movement is generated:</p> <ol style="list-style-type: none"> 1) Air remains in the cylinder (possible poor air-bleeding, the air in the hydraulic circuit inhibits the function) 2) The oil level is too low 3) One or both check valves in the hydraulic unit have jammed or their opening pressure is too high 4) The locking solenoid valve does not close completely 5) The solenoid valve for the movement control (3-position valve) fails to switch 6) The maximum pressure in the main unit is too low for the application (default setting 180 bar). 	<p>If the movement is commanded (LED1, LED7, either LED 3 or 4 illuminates), but this does not occur, check the following:</p> <ol style="list-style-type: none"> 1) Pump operation 2) Solenoid valves for left and right movement 3) Actuation of the check valves in the hydraulic block 4) If the movement is delayed, check the hydraulic circuit and the oil level 5) If the movement occurs with uncertain or insufficient force, check the actuation of the blocking solenoid valve, the actuation of the check valves in the block of the hydraulic unit and the pressure setting of the overpressure valve, particularly if this occurs only when the vehicle is loaded
<p>Warning lamp The warning lamp illuminates as soon as the alarm is tripped and stays on until the electronic system is switched off.</p>	

Maintenance 5

Diagnostic warnings 5.2

Warning code 19 - Electronic control unit not calibrated oder Kein EBS-Signal bei hoher Geschwindigkeit im Vorwärtsgang		Electronic control unit not calibrated
<p>Meaning During a diagnostic procedure, the electronic control unit detects a malfunction or a calibration error of an internal component.</p> <p>Execution The check is run each time the electronic system is switched on and if the reversing light does not illuminate.</p> <p>Consequences If this warning occurs, the axle returns freely to the self-steering condition. Reversing is not possible without the axle lock.</p> <p>Possible cause One or both microprocessors in the electronic control unit have been replaced</p>		
Possible primary cause	Possible corrective measures	
An internal component of the electronic control unit is faulty or has changed its operating parameters	Memory reset required. Contact BPW.	
<p>Warning lamp The warning lamp illuminates as soon as the alarm is tripped and stays on until the electronic system is switched off.</p>		
<p>Meaning This error is detected if the vehicle is travelling at a speed above 15 km/h for longer than 3 seconds when the EBS signal is active.</p> <p>Execution When the vehicle is travelling in forward gear.</p> <p>Consequences If this warning occurs, the axle returns freely to the self-steering condition. Reversing is not possible without the axle lock.</p> <p>Possible cause The EBS-ISS output was programmed incorrectly and provides 24 V voltage above 10 km/h.</p>		EBS ISS signal present at high speed in forward gear
Possible primary cause	Possible corrective measures	
The EBS control unit is programmed to issue the signal at speeds above 10 km/h. - The EBS plug is connected to an active power supply even at high speed. - The ARCEBS connection cable is defective.	Make sure that the signal at the EBS plug is not present at speeds above 10 km/h. To check the ARCEBS1 interface cable, disconnect the EBS plug and check that the L22 LED is off.	
<p>Warning lamp The warning lamp illuminates as soon as the alarm is tripped and stays on until the electronic system is switched off.</p>		

6 Maintenance intervals

BPW Active Reverse Control does not require fluids or components to be replaced on a regular basis. Given the fact that this system is mounted on a working vehicle, it is advisable to perform a visual inspection at regular intervals.

Thanks to the Active Reverse Control, the BPW self-steering axle does not require any additional maintenance. The known maintenance intervals for the BPW self-steering axle must be respected. They are stated in the BPW maintenance instructions and the workshop manual.

Measure	Interval
Check the warning lamp is functioning correctly. Make sure it flashes briefly when switched on.	At each start
Check whether the oil level is approximately 3/4 of the tank capacity. Make sure that the oil is not contaminated with water by visually inspecting the oil colour (oil must be completely clear and must not look cloudy or emulsified). Visually inspect the hydraulic unit, the lines and their connections and also the steering cylinder for oil leaks.	One month after initial installation/repair Once a year thereafter
Check the electrical connections, paying particular attention to the condition of the cables on the axle, and also between vehicle frame and axle.	One month after initial installation/repair Once a year thereafter
Check the power supply connections on the front of the semi-trailer and on the towing vehicle. Make sure that they are not corroded or damaged. Check the condition of the power cables between truck and semi-trailer, and also the condition of the cables on the truck. They must never be damaged or rubbed.	One month after initial installation/repair Once a year thereafter
Check the distance between the proximity switch and the locking mechanism (factory setting: 2 mm between sensor and locking block). Sensor must be firmly located in the support.	One month after initial installation/repair Once a year thereafter
Visual inspection of the status of the mechanical components of the additional steering system. (Mounting of the steering cylinder, support on the track rod). Tighten the mounting of the steering cylinder if necessary. Tighten castle nuts to 250–280 Nm and continue turning up to the first bore hole. Fix position with split pin. The hydraulic cylinder must be firmly located in the support.	One month after initial installation/repair Once a year thereafter
General lubrication work on LL axles	See the steering axles workshop manual (chapter 6)
Lubrication work on N..LL axles with ARC (with brake SN 3020 – low loader trailer) Lubricate steering cylinder joint heads	Every 6 weeks
Replace the tensioner heads on the track rod (SGS bushes)	After 2 years
Replace the ball pivots of the steering cylinder (axles with TS2 3709 / 4309 / SN 4218 / 4220 brakes) or joint heads (N..LL axles with SN 3020 brake – low loader trailer)	After 3 years
Oil change: Drain used oil via the bleed screws of the steering cylinder.	After 5 years

Safety and the environment 7

Hazardous waste must be disposed of in accordance with the regulations applicable at the location. For further information, contact your local authority.

BPW ist ein weltweit führender Hersteller von intelligenten Fahrwerkssystemen für Anhänger und Auflieger. Von der Achse über Federung und Bremse bis hin zu anwenderfreundlichen Telematikanwendungen bieten wir als Mobilitätspartner und Systempartner Lösungen für die Transportindustrie aus einer Hand.

Damit schaffen wir höchste Transparenz in Verlade- und Transportprozessen und ermöglichen ein effizientes Flottenmanagement. Hinter der traditionsbewussten Marke für Trailerachsen steckt heute eine internationale Unternehmensgruppe mit einem breiten Produkt- und Dienstleistungsportfolio für die Nutzfahrzeugindustrie. Mit Fahrwerkssystemen, Telematik, Beleuchtungssystemen, Kunststofftechnologie und Aufbautentechnik ist BPW der Systempartner für Fahrzeughersteller.

Dabei verfolgt BPW als inhabergeführtes Unternehmen konsequent ein Ziel: Ihnen immer genau die Lösung zu bieten, die sich am Ende für Sie auszahlt. Dafür setzen wir auf kompromisslose Qualität für hohe Zuverlässigkeit und Lebensdauer, gewichts- und zeitsparende Konzepte für geringere Betriebs- und Wartungskosten sowie persönlichen Kundendienst und ein dichtes Servicenetz für schnelle und direkte Unterstützung. So können Sie sicher sein, mit Ihrem Mobilitätspartner BPW immer den wirtschaftlichen Weg zu gehen.

Your partner on the path to economic viability



BPW Bergische Achsen Kommanditgesellschaft

Postbox 12 80 · 51656 Wiehl, Germany · Phone +49 (0) 2262 78-0
info@bpw.de · www.bpw.de